

**DIVISION 500**  
**STRUCTURES**

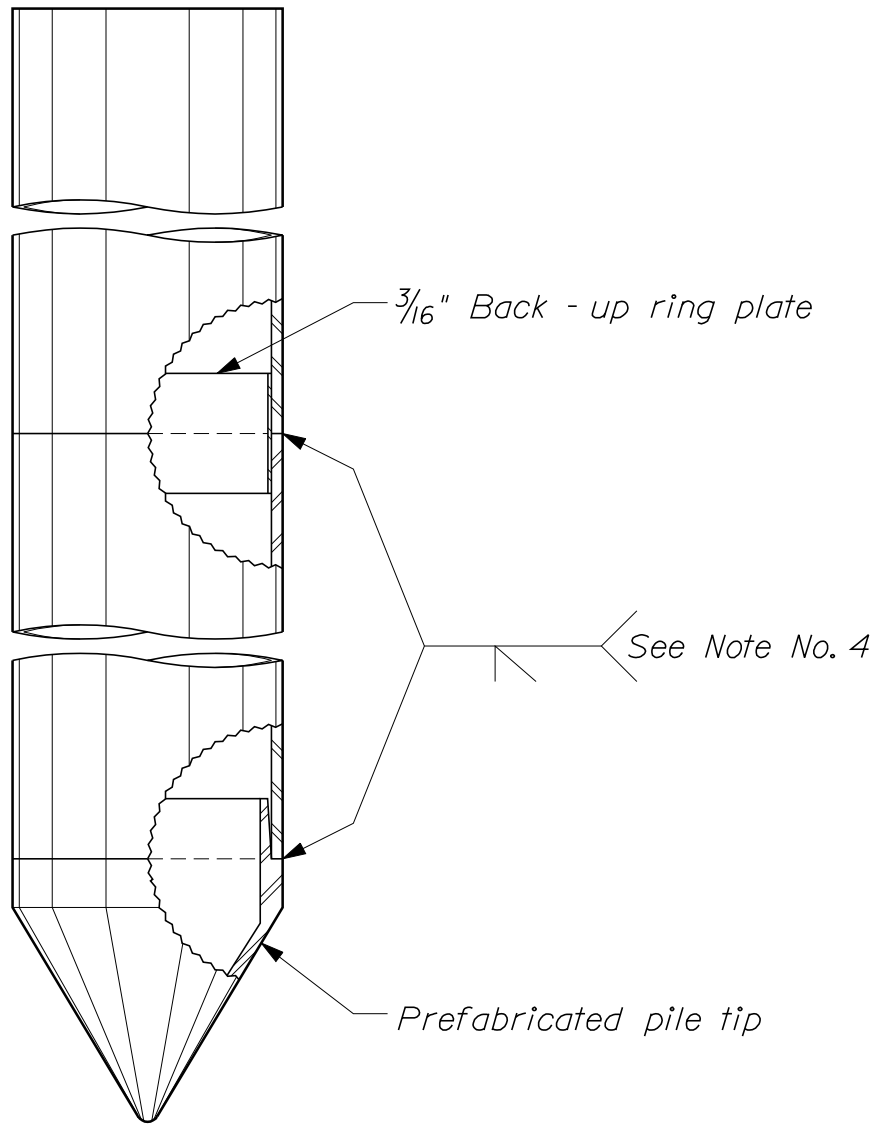

~ PIPE PILE DETAIL ~

**NOTES:**

1. Pile diameter and wall thickness shall be as indicated on the Design Drawings.
2. Pile tips shall be prefabricated cast steel tips with 60° conical points and internal flanges. Pile tips shall be approved by the Engineer.
3. Prefabricated internal splicer sleeves may be used if approved by the Engineer.
4. Refer to "Pipe Pile Splice" details for welding procedures.

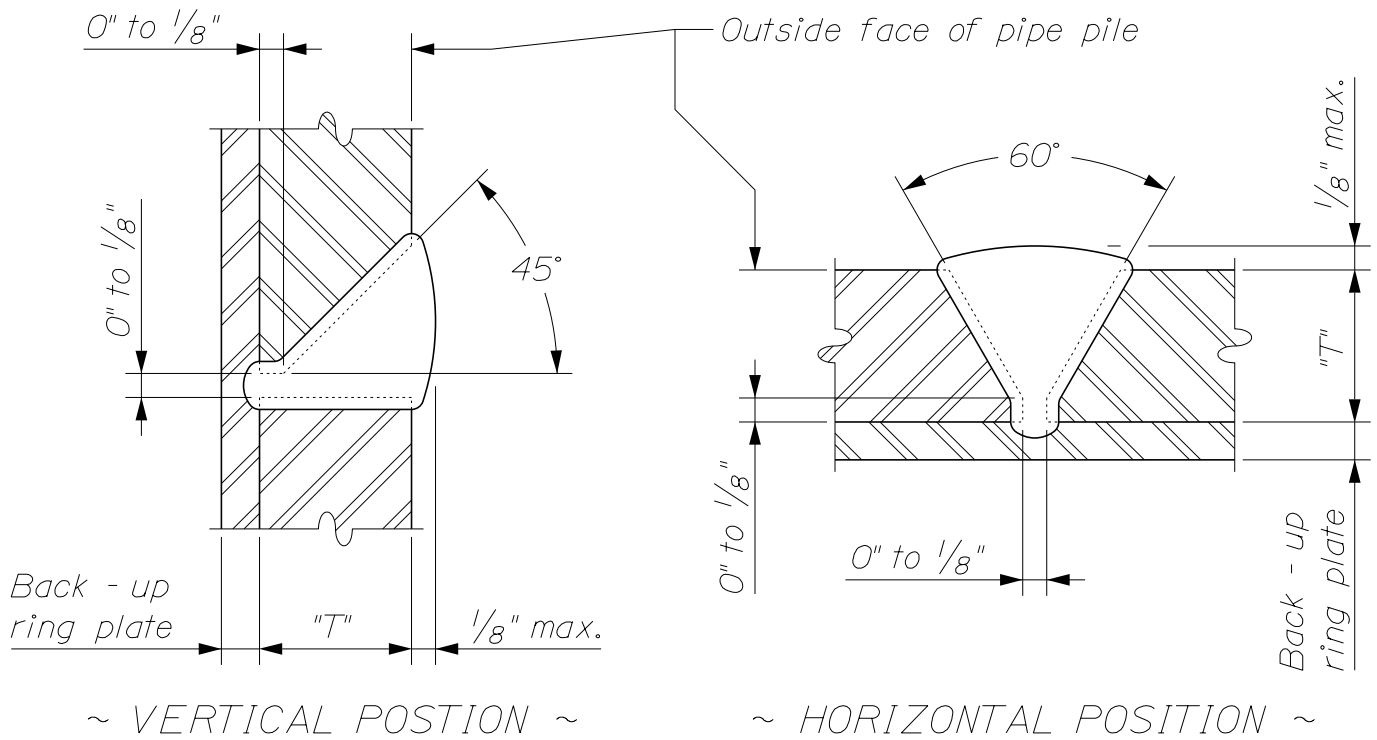

<i>TABLE OF WELD SIZES</i>	
<i>Base Metal Thickness "T"</i>	<i>Minimum Number of Passes</i>
$\frac{3}{8}$ " , $\frac{7}{16}$ "	3
$\frac{1}{2}$ " , $\frac{9}{16}$ " , $\frac{5}{8}$ "	4
$\frac{11}{16}$ " , $\frac{3}{4}$ " , $\frac{13}{16}$ "	5

*NOTES:*

- 1. All cutting shall be done with the use of a mechanical guide.*
- 2. Electrodes shall be dry when used, in accordance with A.W.S. Specification D1.5, as amended by AASHTO.*

*PIPE PILE SPLICE*  
501(02)

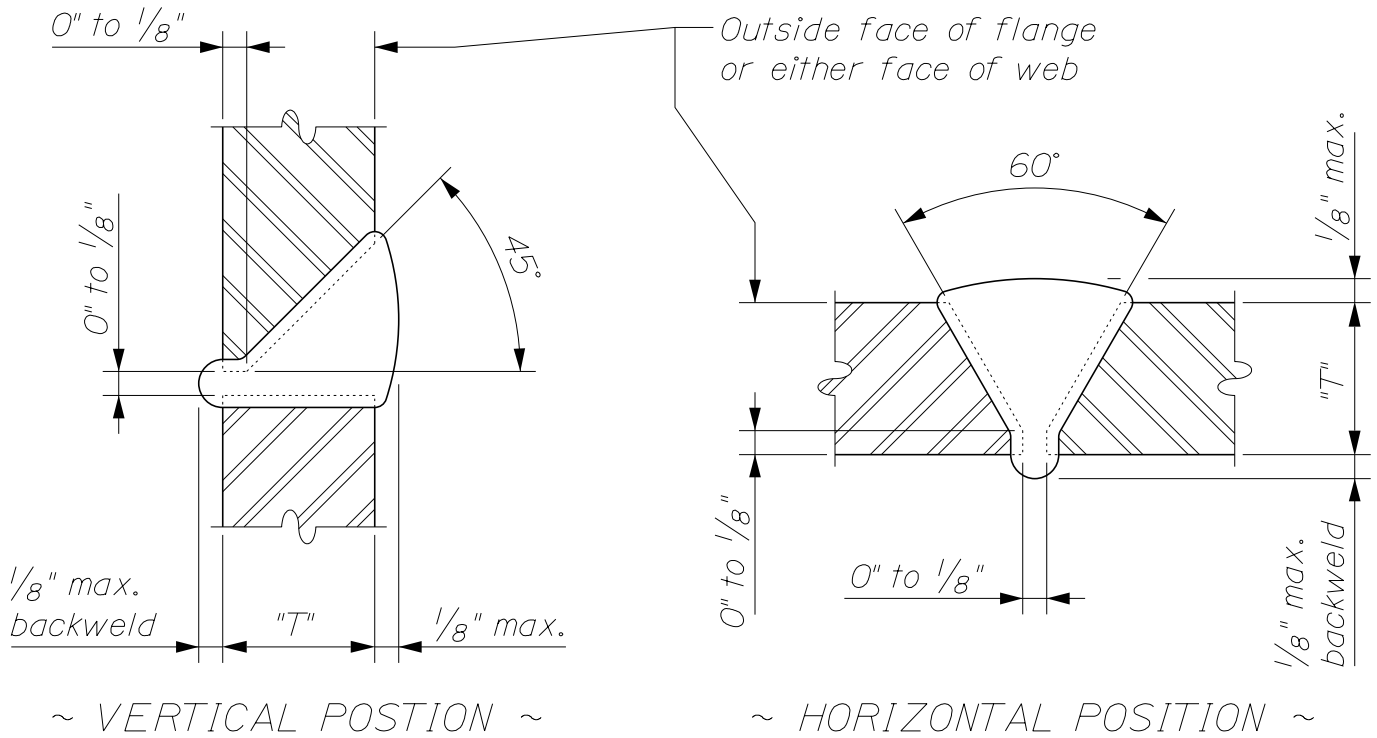
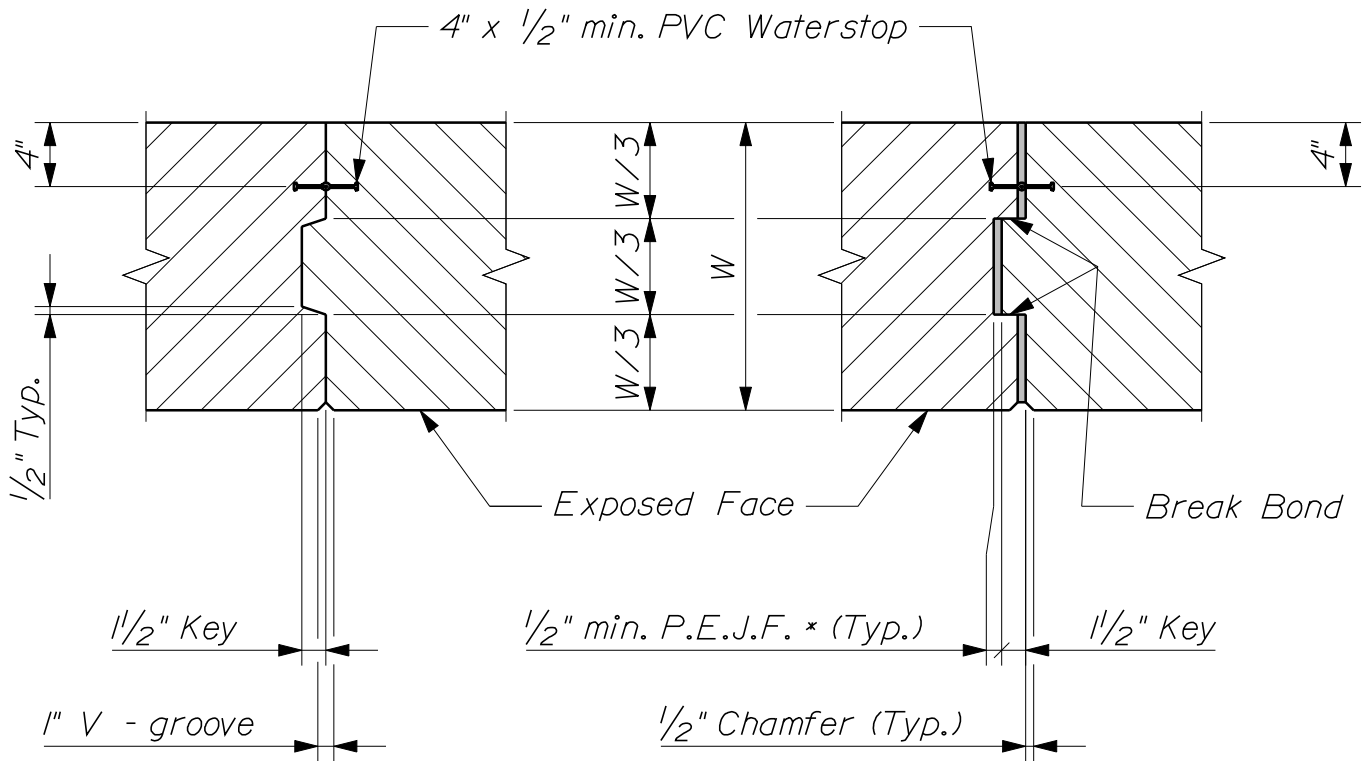

TABLE OF WELD SIZES	
Base Metal Thickness "T"	Minimum Number of Passes
3/8", 7/16"	3
1/2", 9/16", 5/8"	4
11/16", 3/4", 13/16"	5

NOTES:

1. All cutting shall be done with the use of a mechanical guide.
2. Electrodes shall be dry when used, in accordance with A.W.S. Specification DI.5, as amended by AASHTO.
3. Gouge root before welding the second side.

H - PILE SPLICE  
501(03)



~ VERTICAL CONSTRUCTION OR CONTRACTION JOINT ~

~ VERTICAL EXPANSION JOINT ~

\* Preformed Expansion Joint Filler

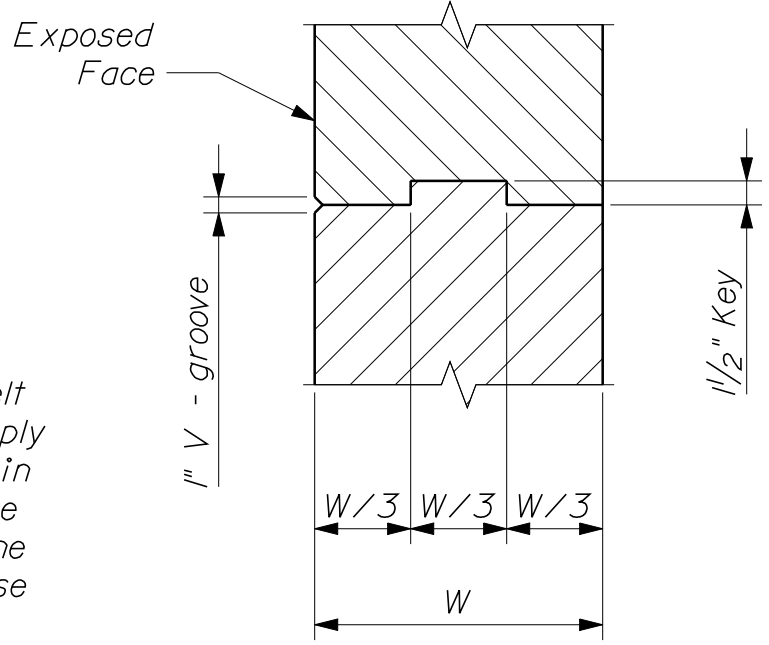
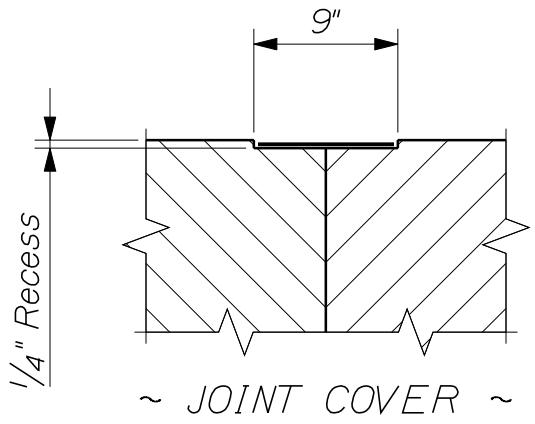

~ HORIZONTAL CONSTRUCTION JOINT ~

Apply 2 layers of heavy roofing felt using plastic roofing cement, or apply 1 layer of membrane waterproofing in accordance with Section 508 of the Standard Specifications. Recess the area to be covered unless otherwise indicated on the plans. Use where PVC waterstops cannot be used and on horizontal joints where there is potential for leakage through the wall.

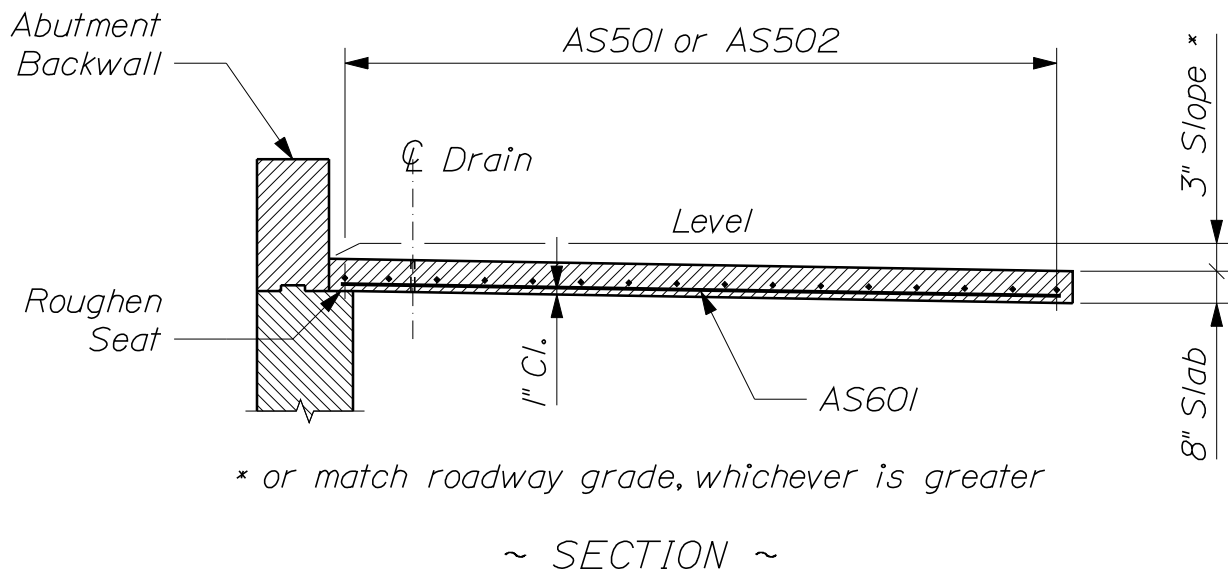
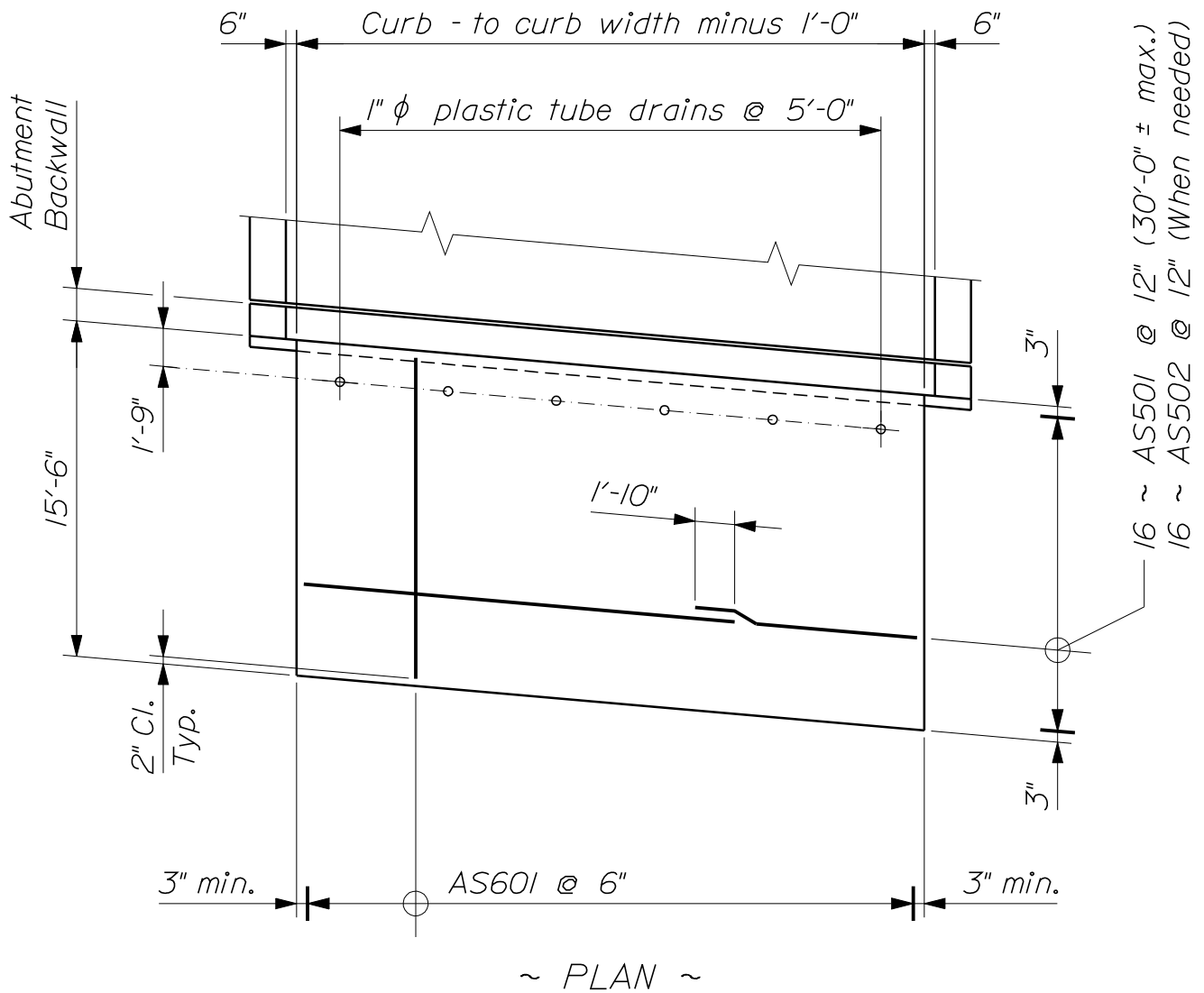

CONCRETE APPROACH SLAB  
502(02)

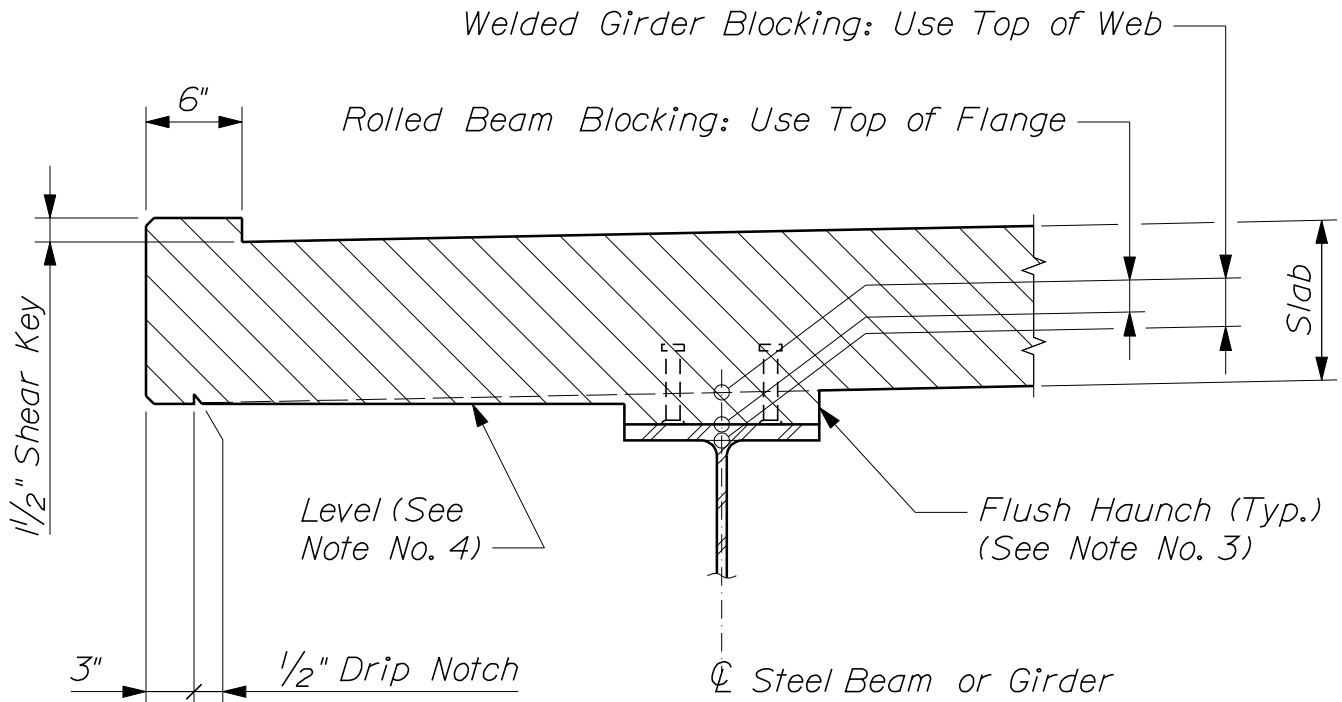

~ SLAB DETAILS ~

NOTES:

1. Shear key and drip notch details are typical for all superstructure designs.
2. Blocking dimensions for construction shall be determined using the "Bottom of Slab Elevations" table shown on the Design Drawings. Theoretical Blocking will be given for reference purposes only. Do not use Theoretical Blocking for setting formwork.
3. Blocking on all beams shall be formed using the flush haunch detail shown.
4. On curved superelevated structures, where the distance between the exterior beam and the fascia varies over the length of the deck, the bottom of the slab overhang shall follow the superelevation cross - slope.

COMPOSITE CONCRETE  
SUPERSTRUCTURE SLAB  
502(03)

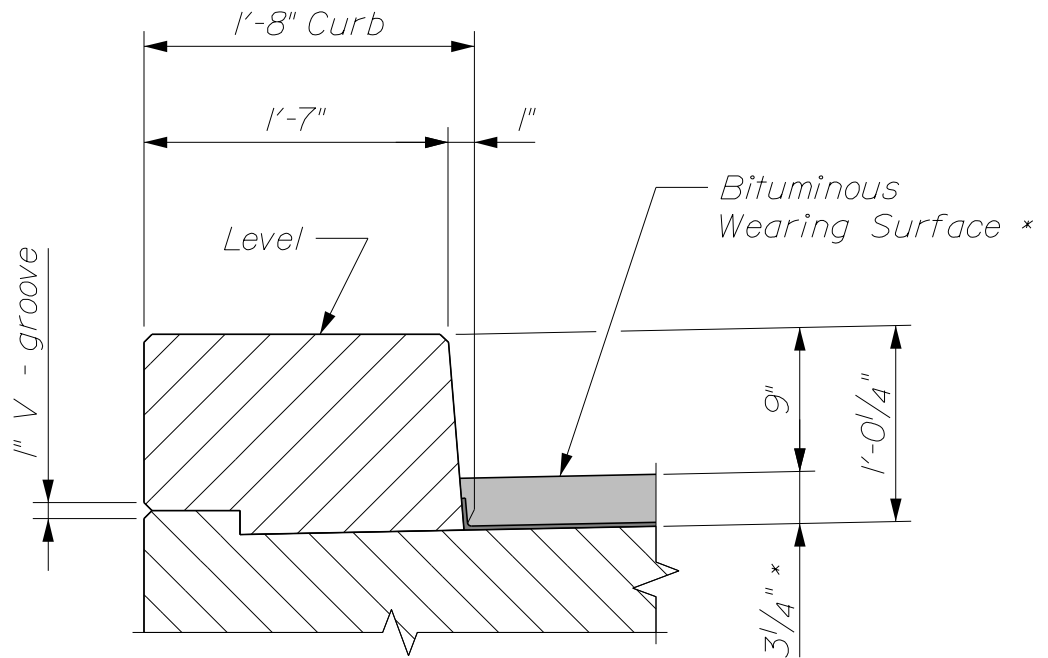

~ CURB WITH BITUMINOUS WEARING SURFACE ~  
 \* 3" Hot Mix Asphalt + 1/4" (nom.) High Performance Waterproofing Membrane

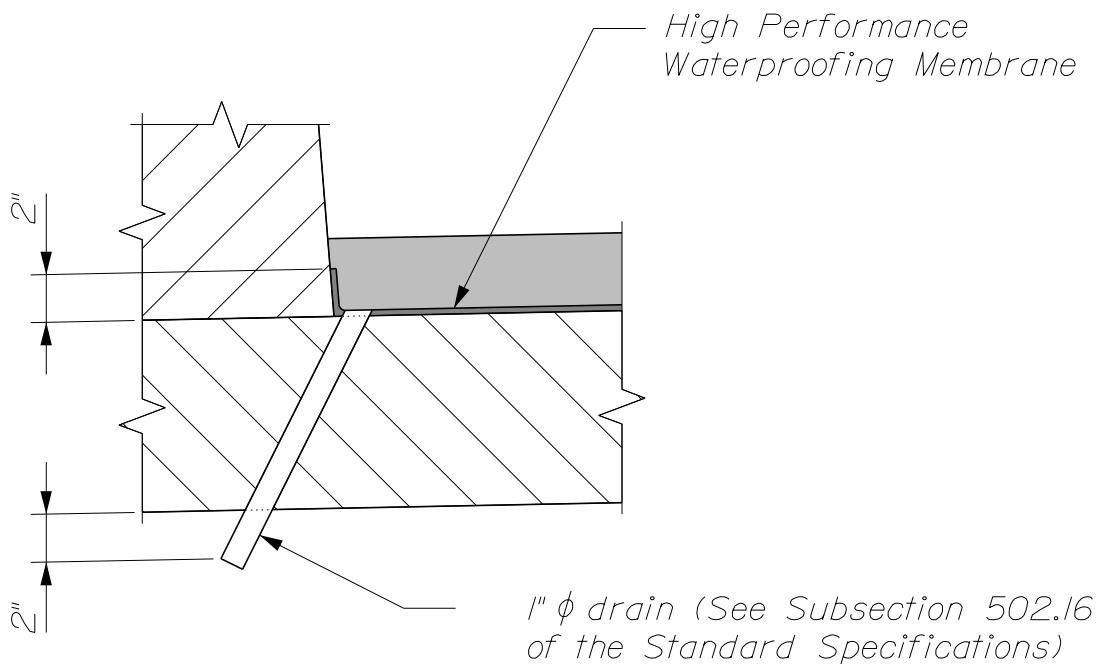

~ GUTTER DETAIL FOR BITUMINOUS W. S. ~

CONCRETE CURB  
 502(04)

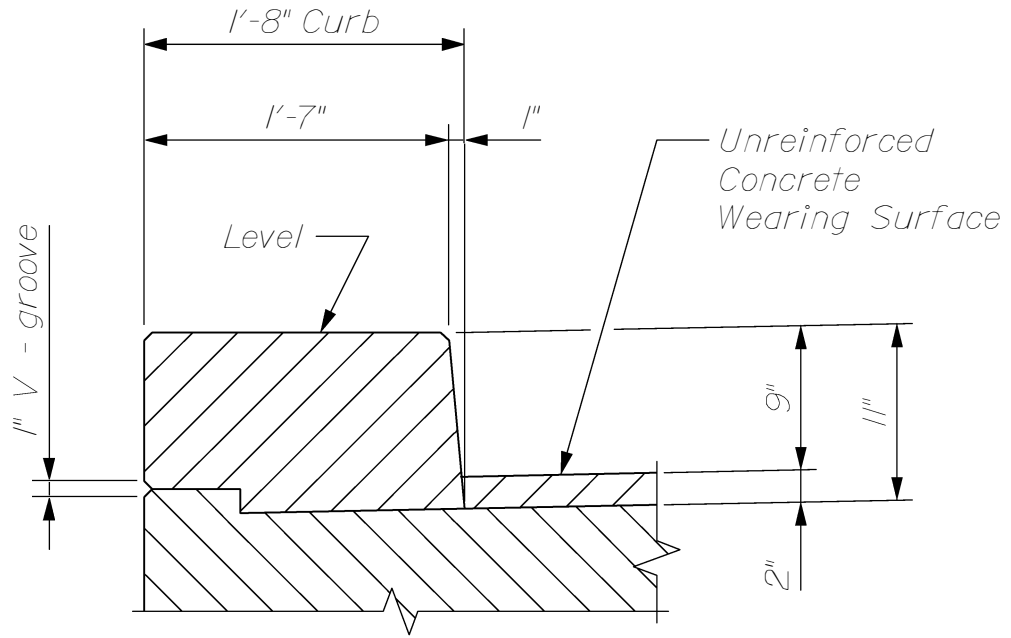

-- CURB WITH CONCRETE WEARING SURFACE --

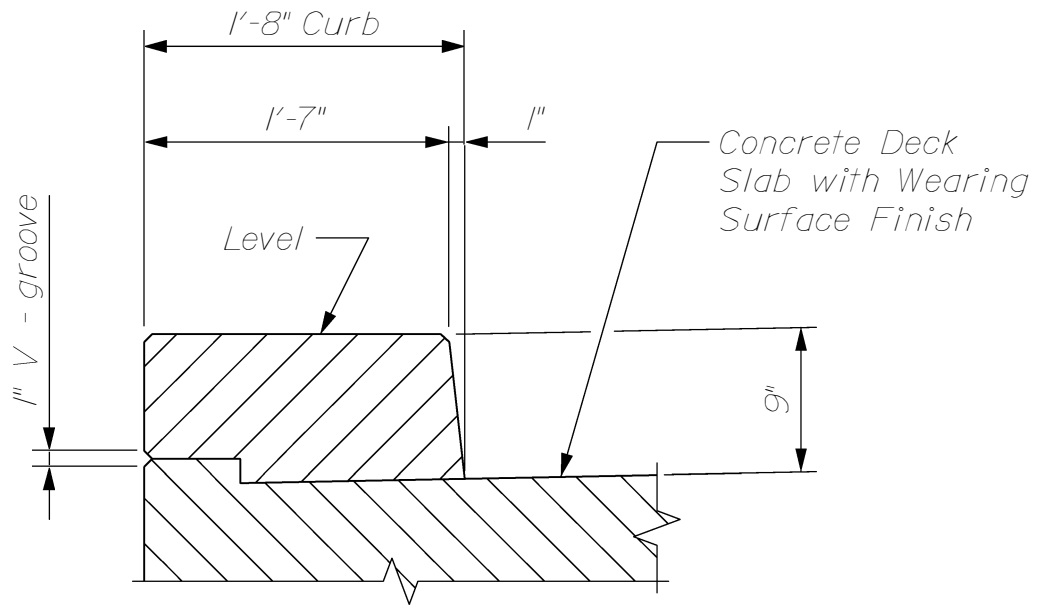

-- CURB WITH INTEGRAL WEARING SURFACE --

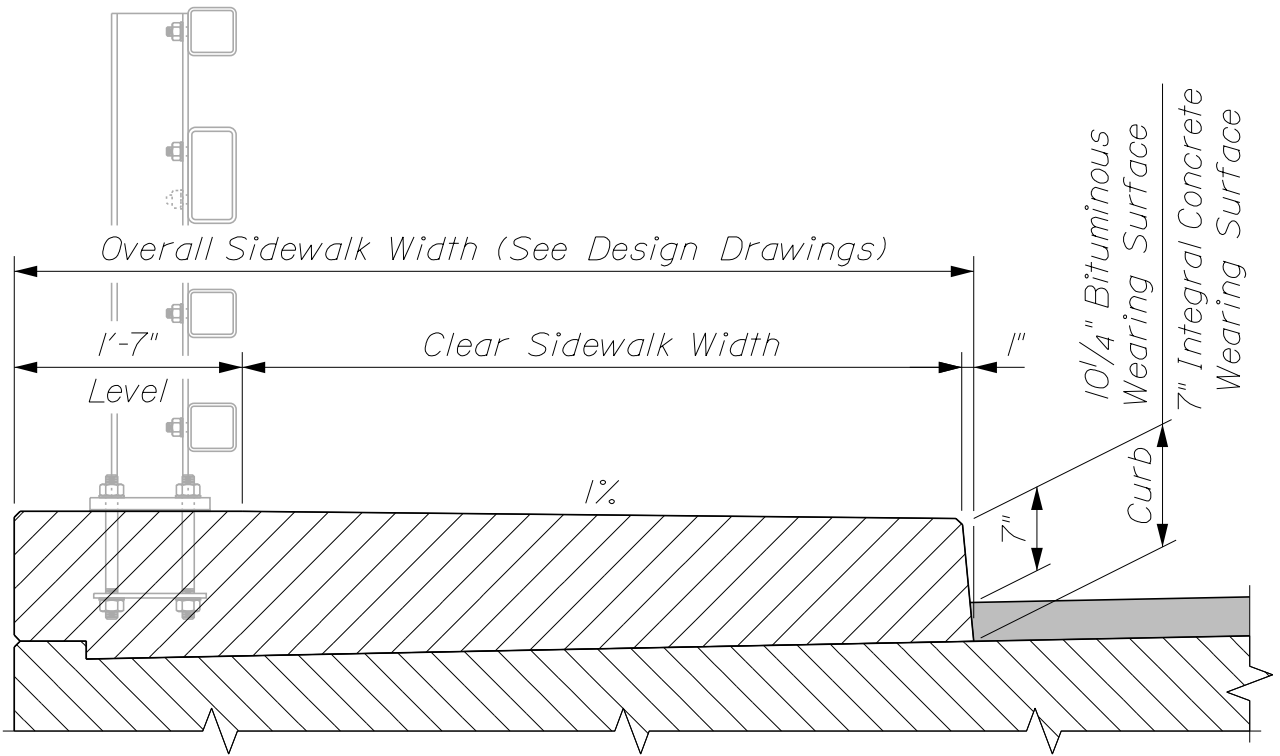

~ WITH STEEL BRIDGE RAILING ~

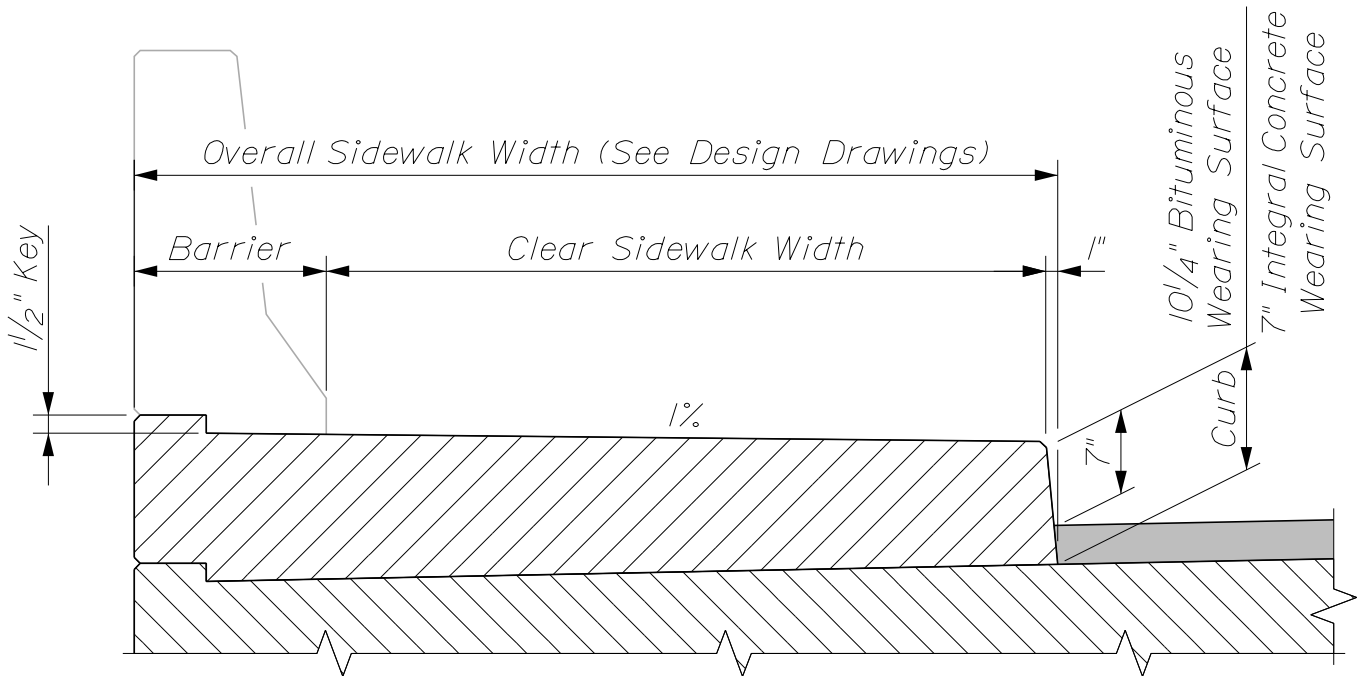

~ WITH PERMANENT CONCRETE BARRIER ~

# CONCRETE SIDEWALK ON BRIDGES

502(06)

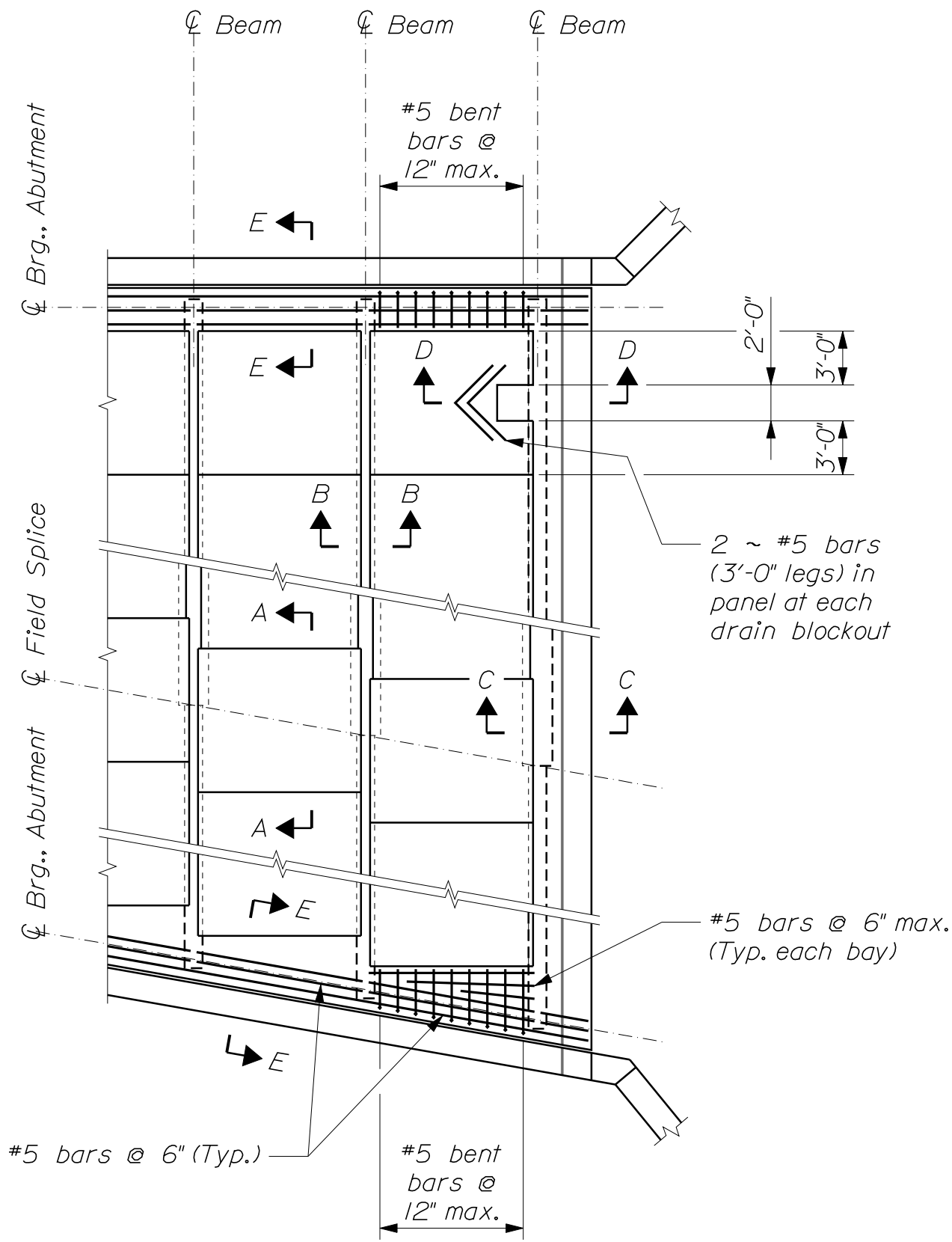

~ LAYOUT PLAN (Cantilevered Abutments) ~

# PRECAST CONCRETE DECK PANELS

502(07)

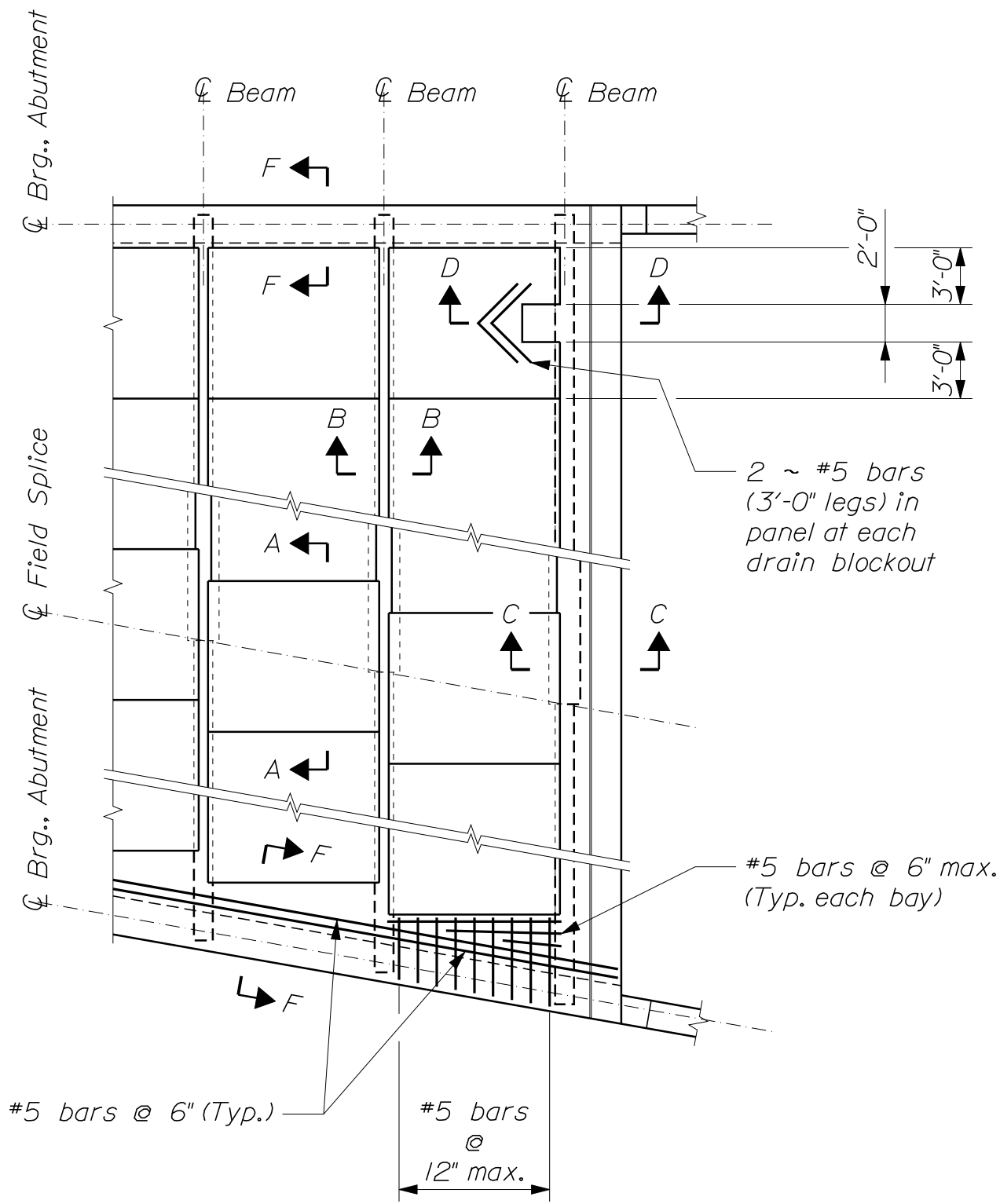

~ LAYOUT PLAN (Integral Abutments) ~

# PRECAST CONCRETE DECK PANELS

502(08)

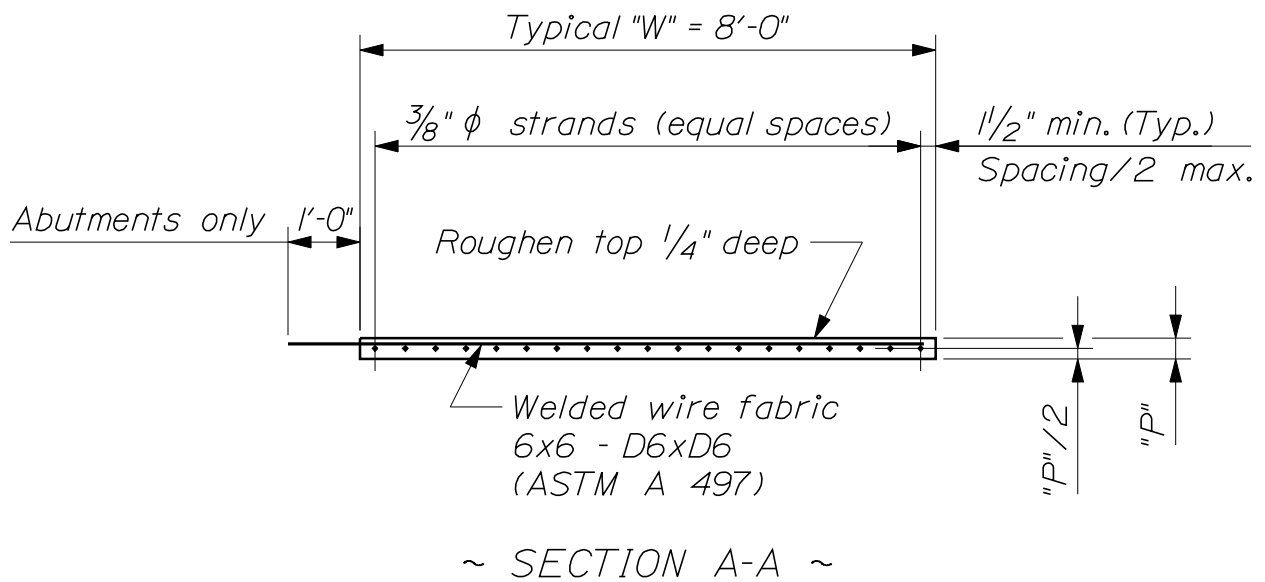
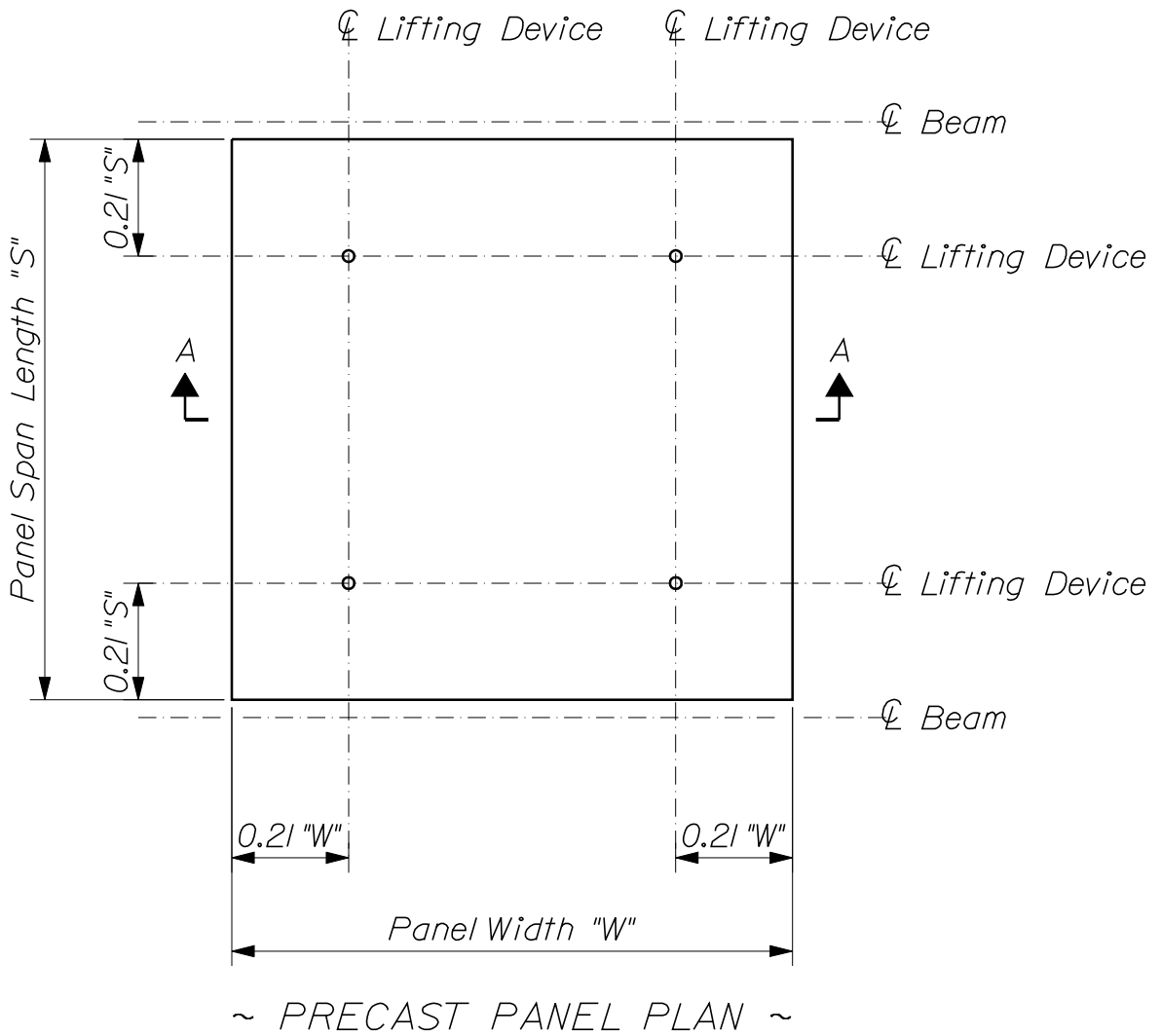

PRECAST CONCRETE DECK PANELS  
502(09)

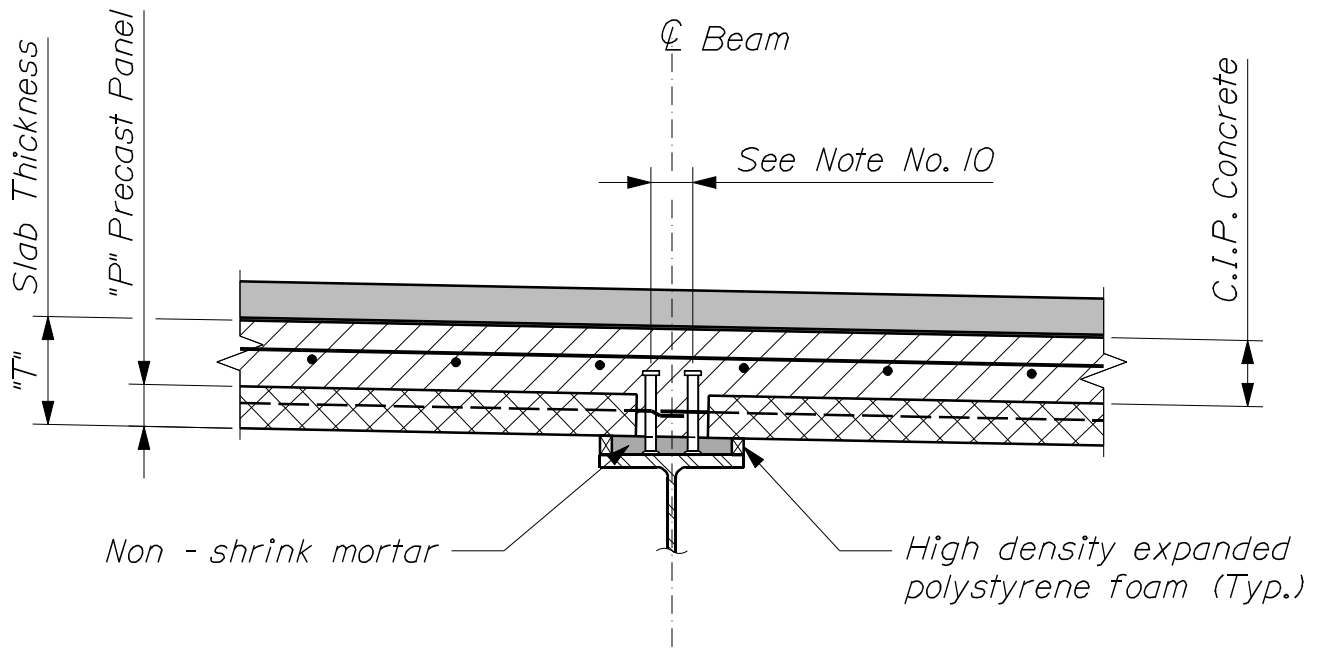

~ SECTION B-B ~

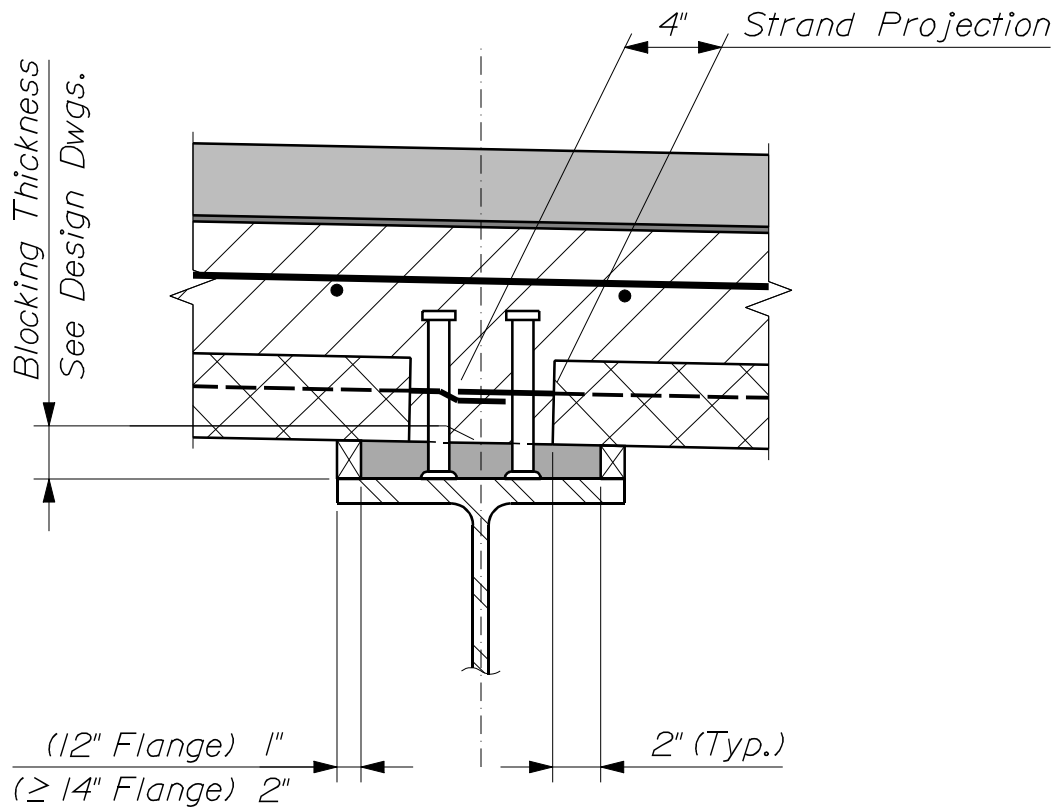

~ BLOCKING DETAIL ~

PRECAST CONCRETE DECK PANELS  
502(10)

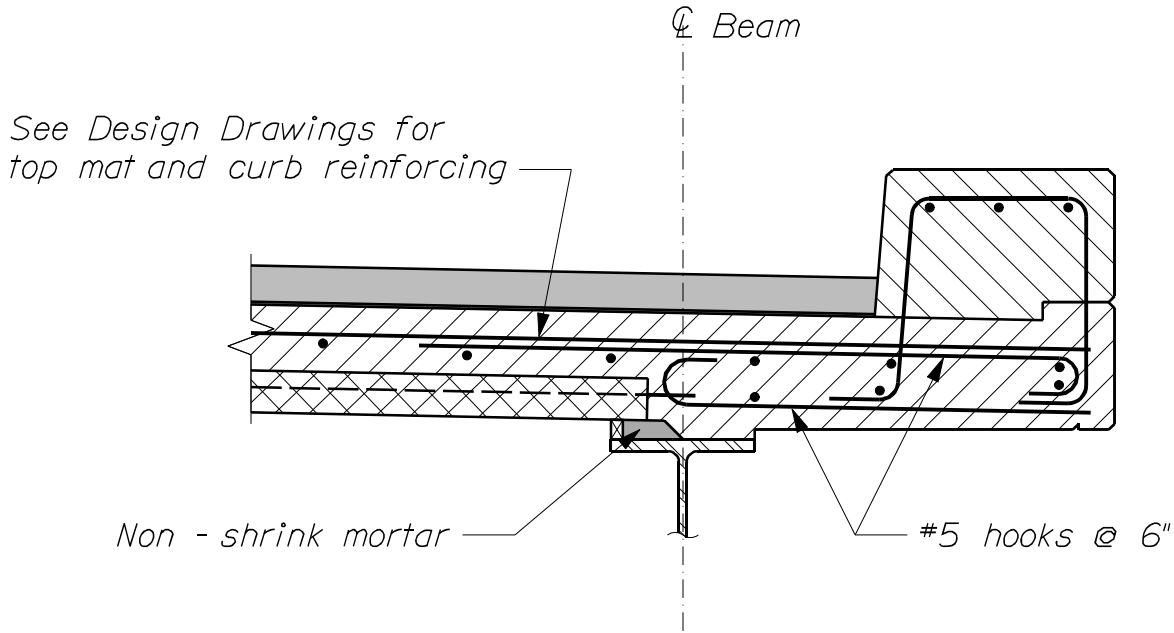

~ SECTION C-C ~

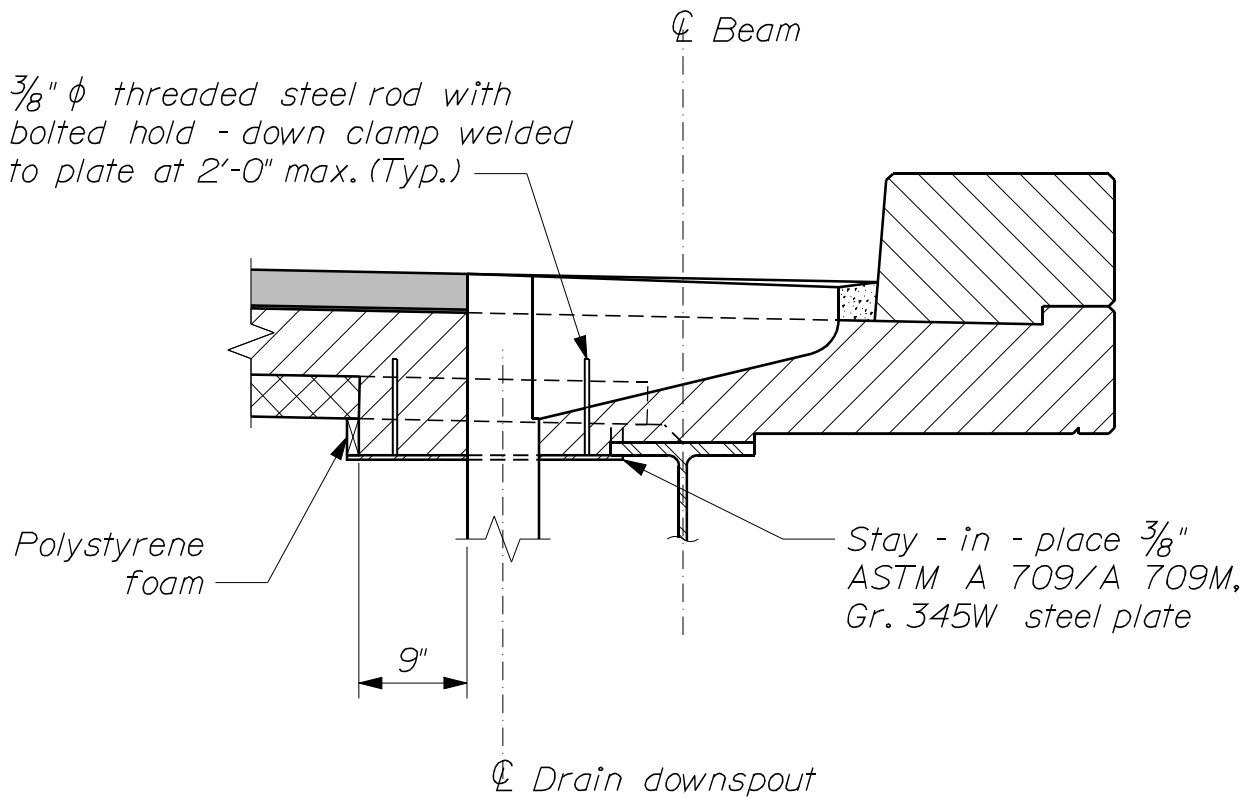

~ SECTION D-D ~

PRECAST CONCRETE DECK PANELS  
502(II)

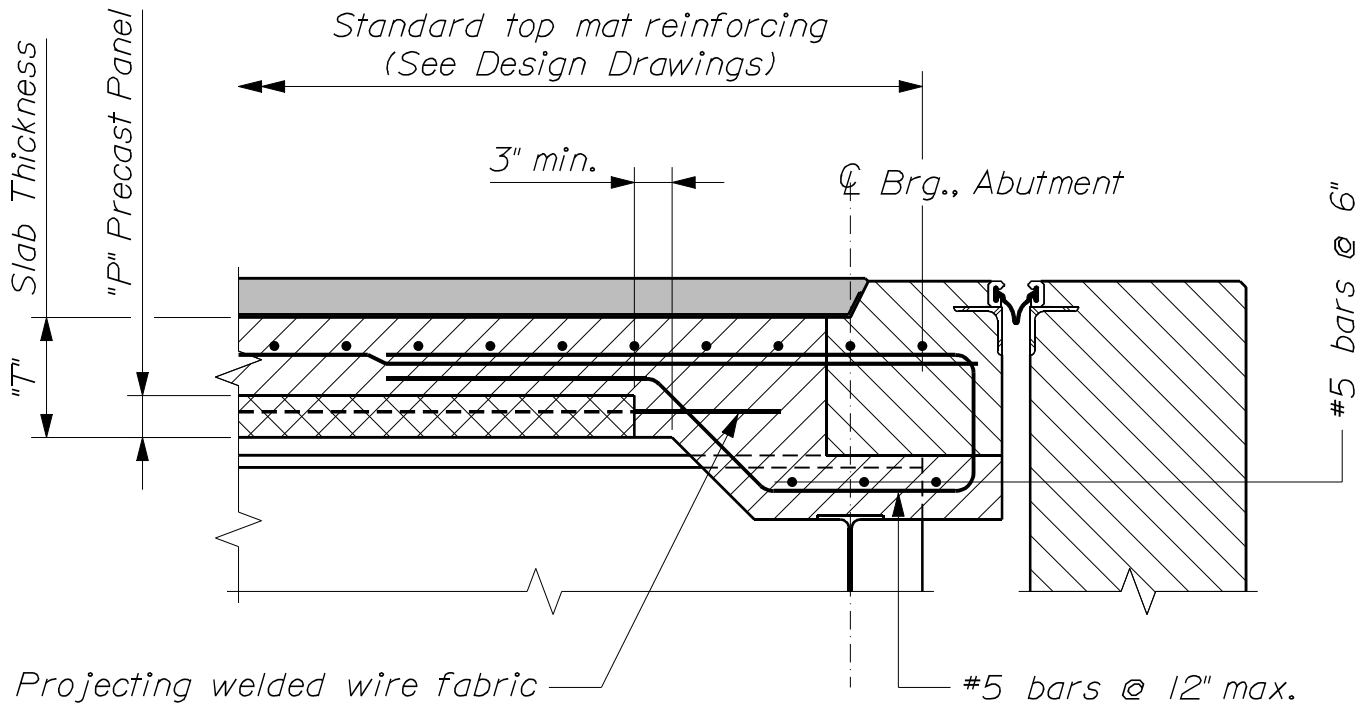

~ SECTION E-E (Cantilevered Abutment) ~

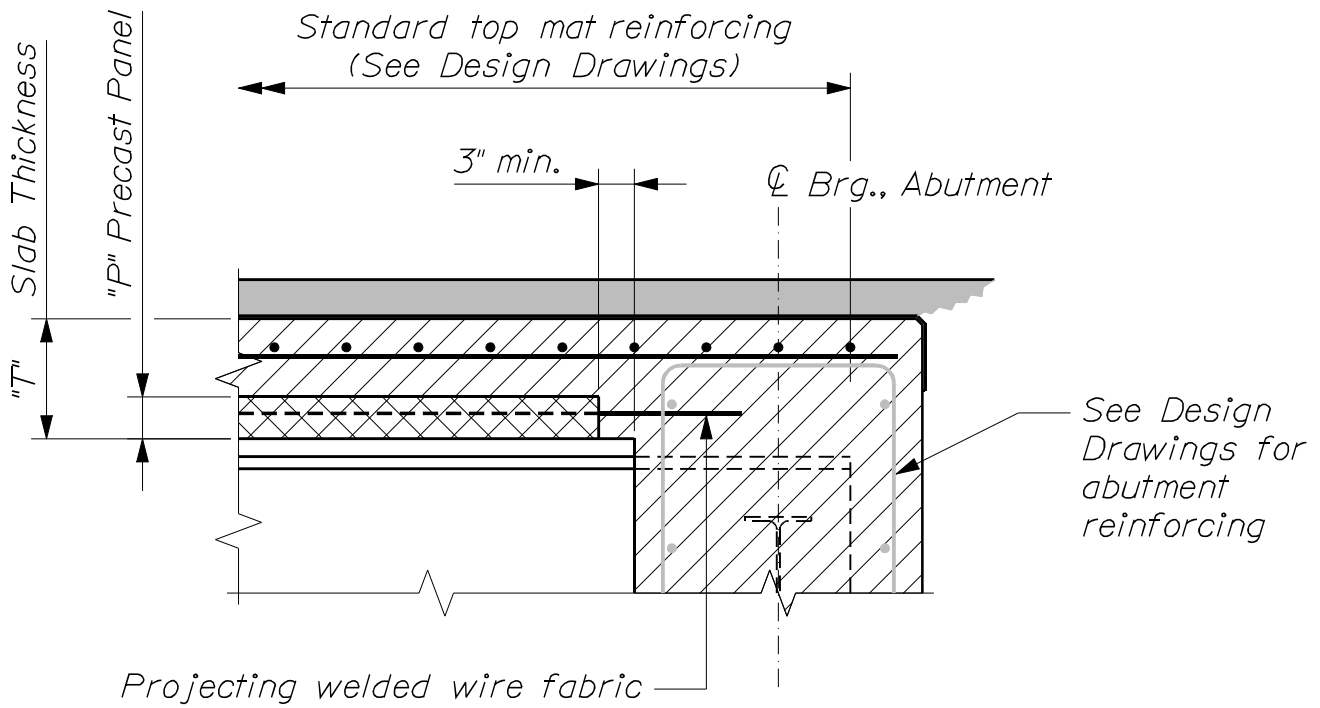

~ SECTION F-F (Integral Abutment) ~

# PRECAST CONCRETE DECK PANELS

502(12)

<i>PRECAST PANELS ON STEEL GIRDERS</i>						
<i>Panel Type</i>	<i>Maximum Girder Spacing</i>	<i>Slab "T"</i>	<i>Panel "P"</i>	<i>Number of Strands</i>		
				<i>Flange Width</i>		
				<i>1'-0"</i>	<i>≤ 1'-6"</i>	<i>≤ 2'-0"</i>
<i>A1</i>	<i>7'-6"</i>	<i>8"</i>	<i>3 1/2"</i>	<i>15</i>	<i>15</i>	<i>15</i>
<i>A2</i>	<i>8'-0"</i>	<i>8"</i>	<i>3 1/2"</i>	<i>15</i>	<i>15</i>	<i>15</i>
<i>A3</i>	<i>8'-6"</i>	<i>8"</i>	<i>3 1/2"</i>	<i>17</i>	<i>16</i>	<i>16</i>
<i>A4</i>	<i>9'-0"</i>	<i>8"</i>	<i>3 1/2"</i>	<i>19</i>	<i>17</i>	<i>17</i>
<i>A</i>	<i>9'-6"</i>	<i>8"</i>	<i>3 1/2"</i>	<i>21</i>	<i>19</i>	<i>18</i>
<i>B</i>	<i>10'-0"</i>	<i>8 1/2"</i>	<i>3 1/2"</i>	<i>22</i>	<i>21</i>	<i>19</i>
<i>C</i>	<i>10'-6"</i>	<i>9"</i>	<i>3 1/2"</i>	<i>24</i>	<i>22</i>	<i>20</i>
<i>D</i>	<i>11'-0"</i>	<i>9 1/2"</i>	<i>3 1/2"</i>	<i>27</i>	<i>24</i>	<i>22</i>
<i>E</i>	<i>11'-6"</i>	<i>10"</i>	<i>3 1/2"</i>	<i>30</i>	<i>27</i>	<i>25</i>
<i>F</i>	<i>12'-0"</i>	<i>10 1/2"</i>	<i>3 1/2"</i>	<i>33</i>	<i>30</i>	<i>28</i>

*NOTES:*

- 1. Precast Concrete Deck Panels shall be fabricated in accordance with Section 535 of the Standard Specifications.*
- 2. The contractor shall submit working drawings showing the exact layout of panel types and sizes.*
- 3. Refer to the Design Drawings for structures with curved beams or angled splices.*
- 4. Joints at expansion piers shall be treated similarly to the abutment joint details.*
- 5. Panel widths of less than 8'-0" may be used. Provide strands in the ratio of the smaller panel width to 8'-0", multiplied by the number of strands given in the table, rounding up to the next even number of strands. The minimum panel width is 3'-0"*
- 6. Prestressing strands shall be 3/8-in. diameter Grade 270 seven - wire low relaxation strands conforming to the requirements of ASTM A 416. Initial tension shall be 17.2 kips per strand.*

*(Continued)*

*NOTES (Continued):*

- 7. A mat of #3 reinforcing bars spaced at 6 inches O.C. in each direction may be substituted for welded wire fabric. The welded wire fabric or the reinforcing bars shall have the same corrosion resistance characteristics and/or coating system as the reinforcing steel used in the cast - in - place portion of the deck slab.*
- 8. Concrete for panels shall have a minimum 28 day compressive strength of 5000 psi and a minimum release strength of 4000 psi. Permeability shall be as required for the cast - in - place portion of the deck slab.*
- 9. Precast deck panels require the use of 7-in. long shear connectors rather than the standard 5-in. length. Payment for any additional costs will be considered incidental to the precast deck panel pay item.*
- 10. Where 1'-0" wide girder flanges are specified on the Design Drawings, the transverse shear connector spacing shall be 3 $\frac{1}{2}$  inches rather than the standard 6-in. spacing.*
- 11. When flange thicknesses differ or flange cover plates are used, the temporary blocking thickness shall vary. Precast panels shall align vertically to within  $\frac{1}{4}$  inch.*
- 12. High - density expanded polystyrene foam shall be cut in the field to the required thickness.*
- 13. Mortar to be used for support under the deck panels shall have an approved high range water reducing additive.*
- 14. The specific reinforcing steel layout for the cast - in - place portions of the slab shall be as shown on the Design Drawings.*
- 15. If there is a conflict between these Standard Details and the Design Drawings, the requirements of the Design Drawings shall be followed.*

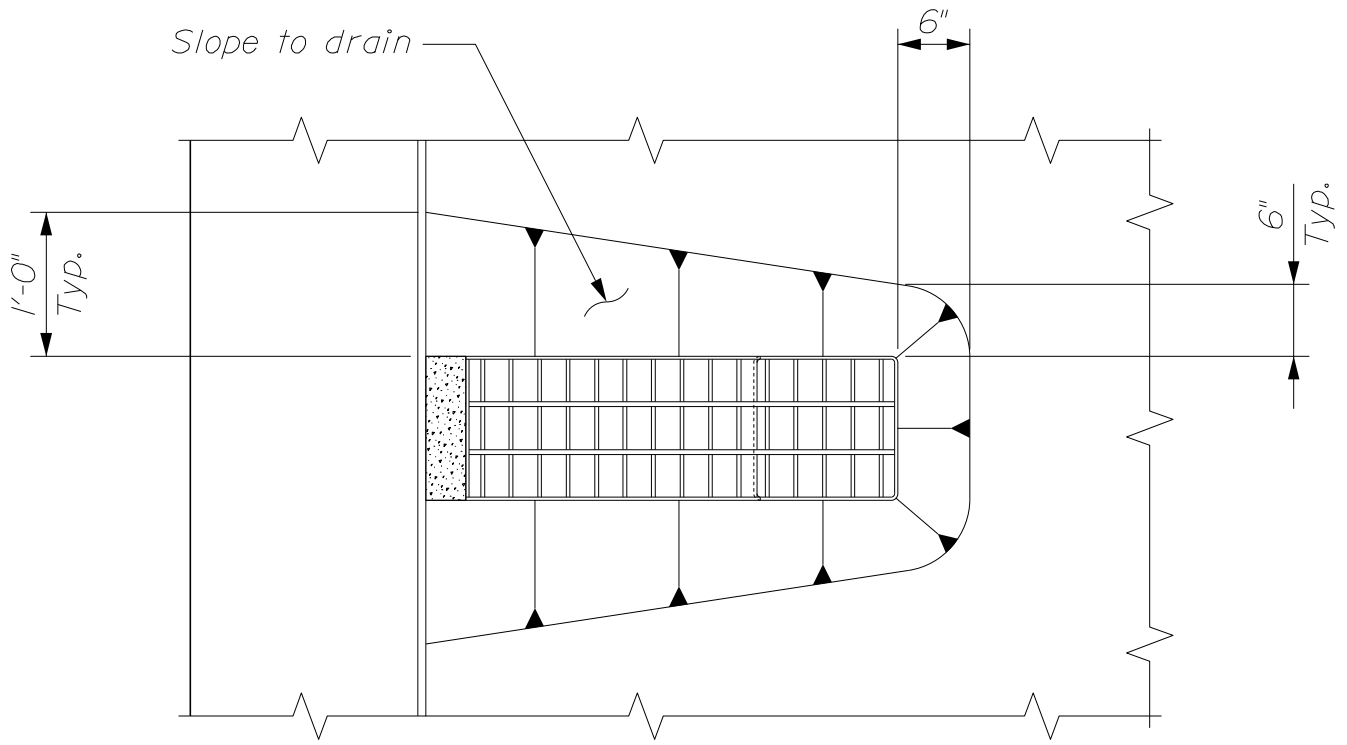

~ LONG PAN BRIDGE DRAIN PLAN ~

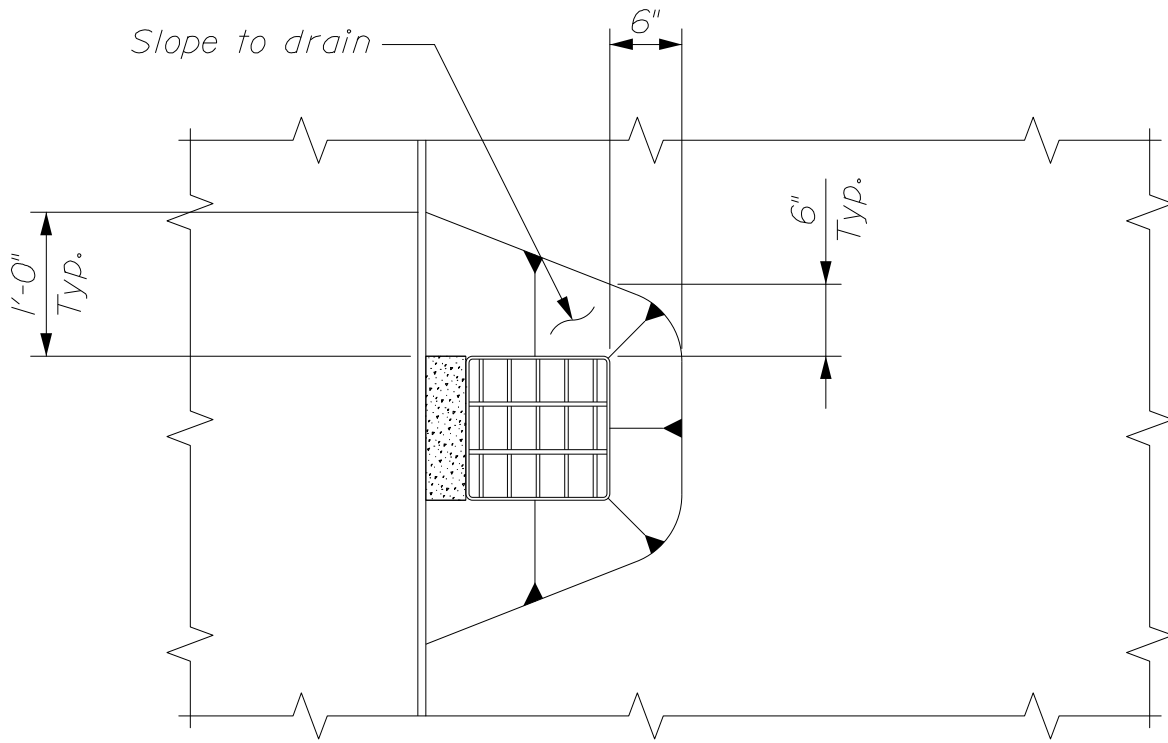

~ SHORT PAN BRIDGE DRAIN PLAN ~

BRIDGE DRAINS  
502(15)

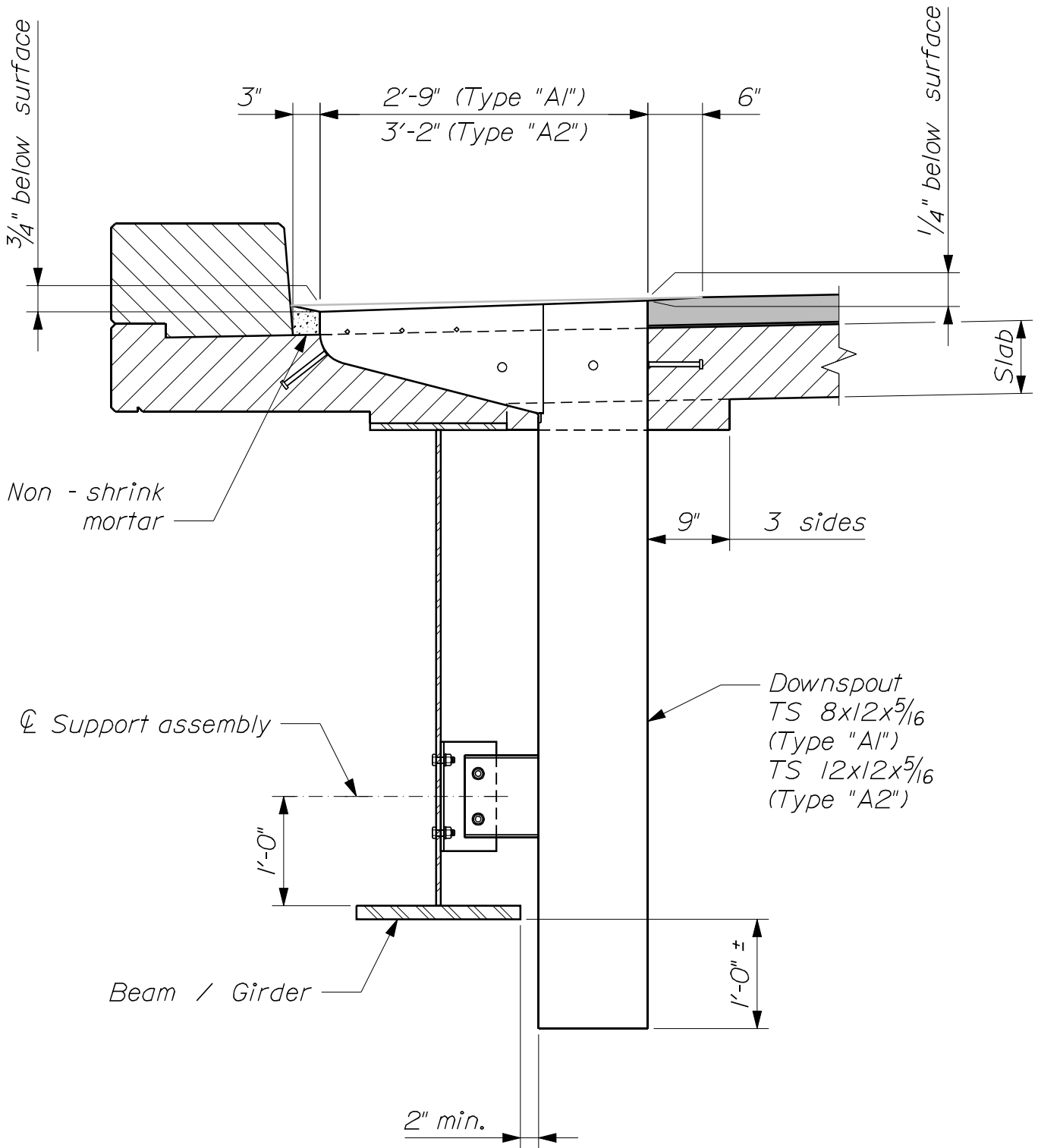

~ BRIDGE DRAIN TYPE "A1" OR "A2" ELEVATION ~

BRIDGE DRAINS  
502(16)

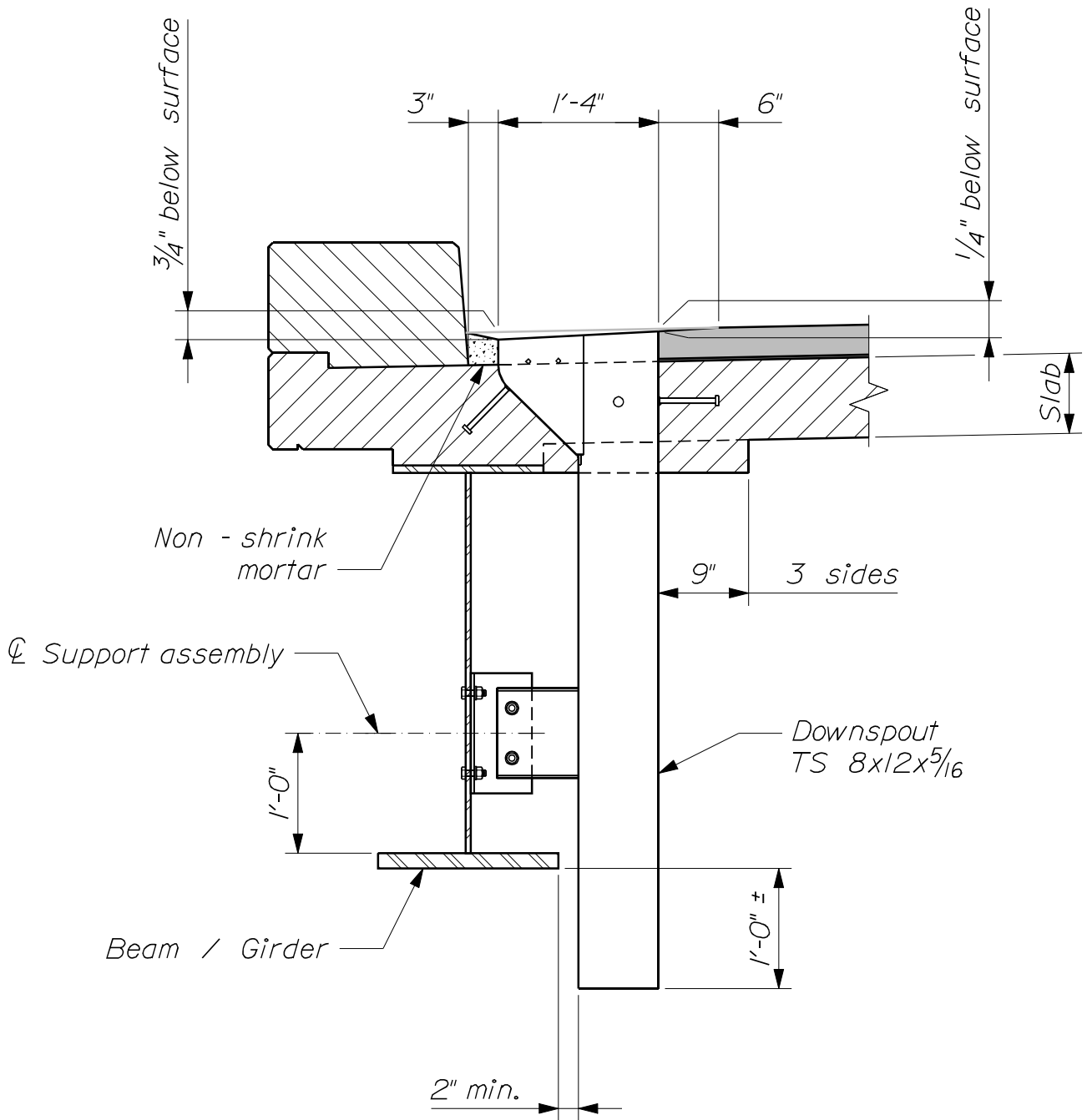

~ BRIDGE DRAIN TYPE "B" ELEVATION ~

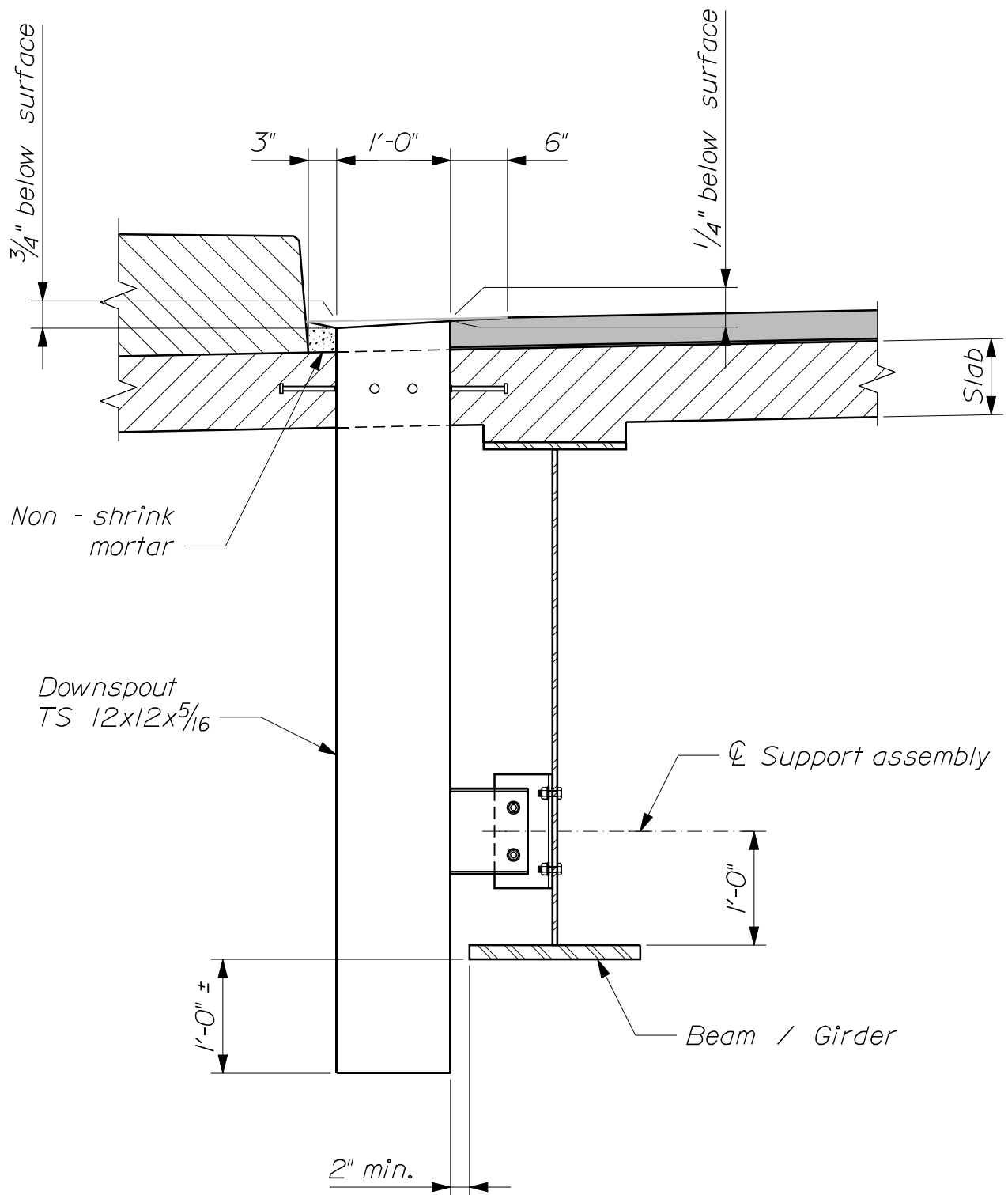

~ BRIDGE DRAIN TYPE "C" ELEVATION ~

BRIDGE DRAINS  
502(18)

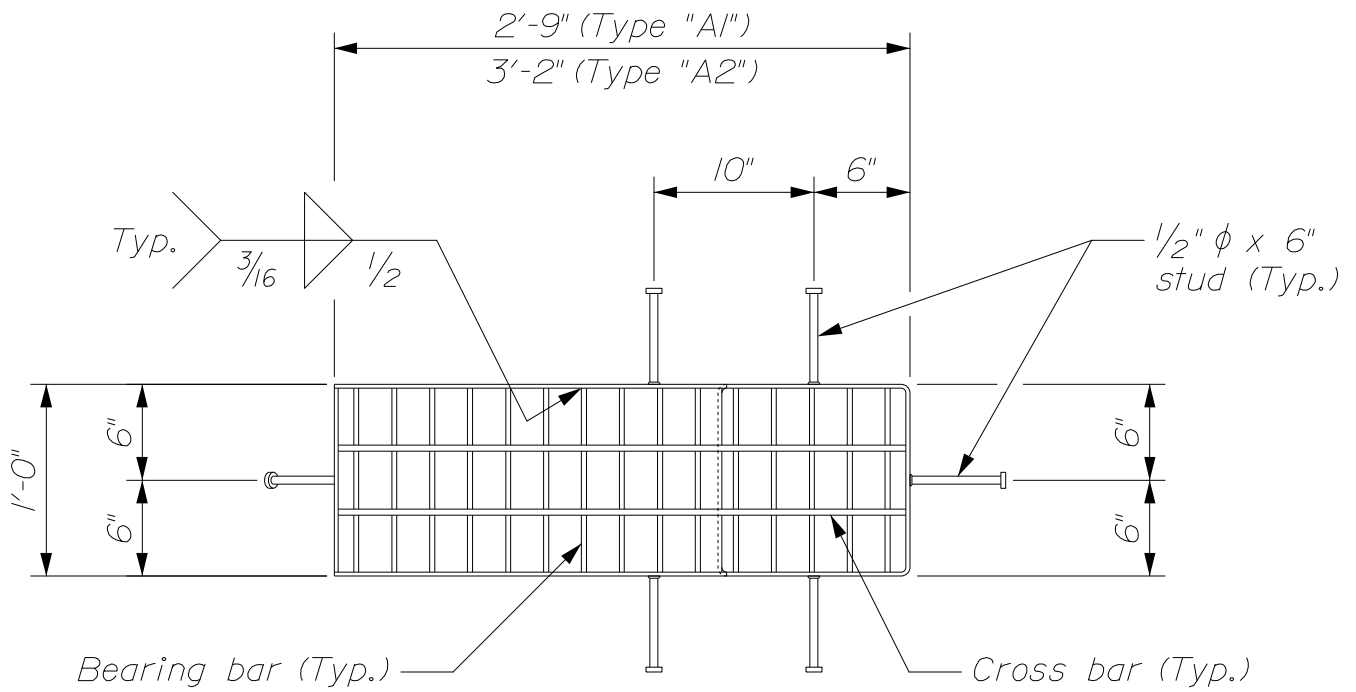

~ DRAIN TYPE "A1" OR "A2" TOP VIEW ~

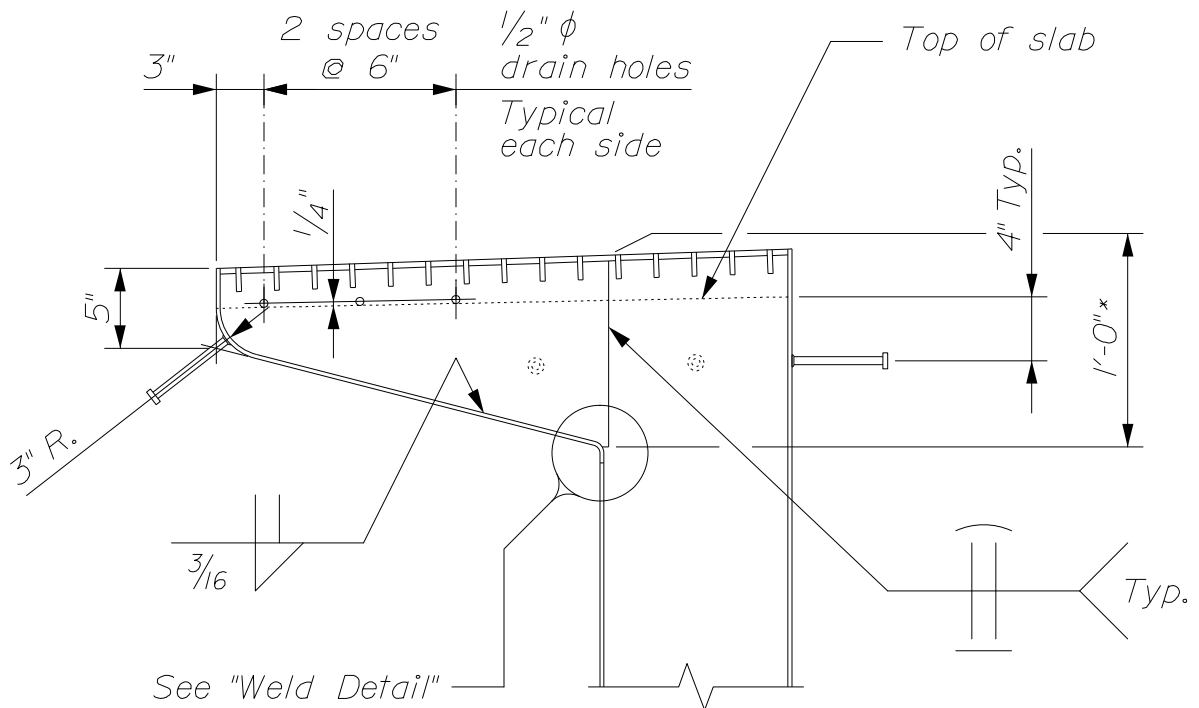

~ DRAIN TYPE "A1" OR "A2" SECTION ~

1'-0" For 3" Thick H.M.A. Wearing Surface.

0'-9" For A 1" Thick Integral Concrete Wearing Surface.

## BRIDGE DRAINS

502(19)

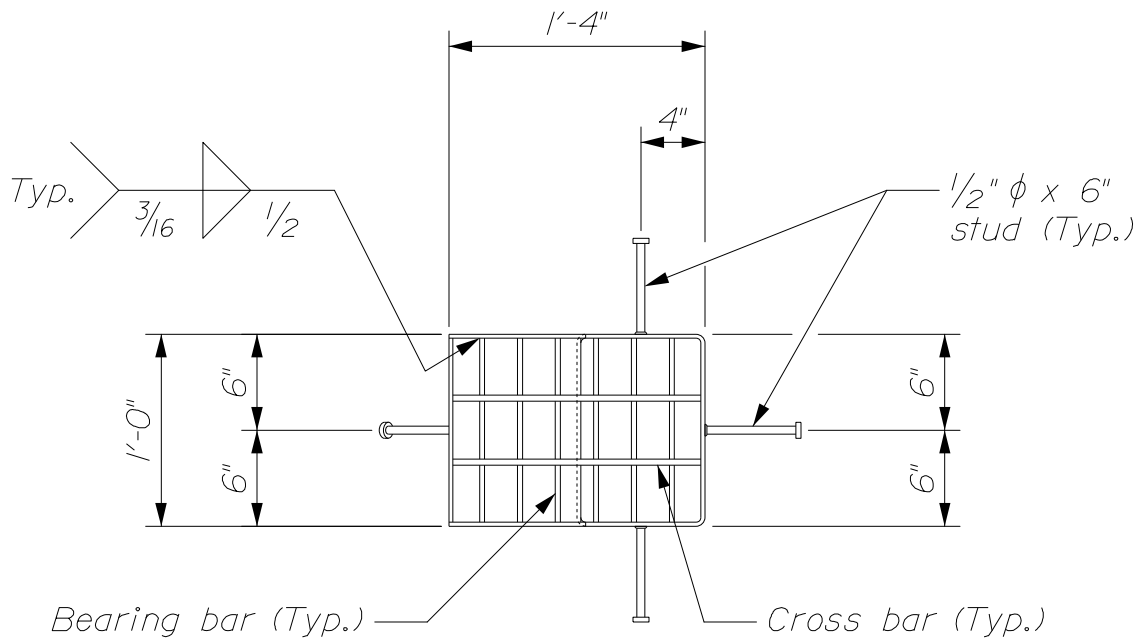

~ DRAIN TYPE "B" TOP VIEW ~

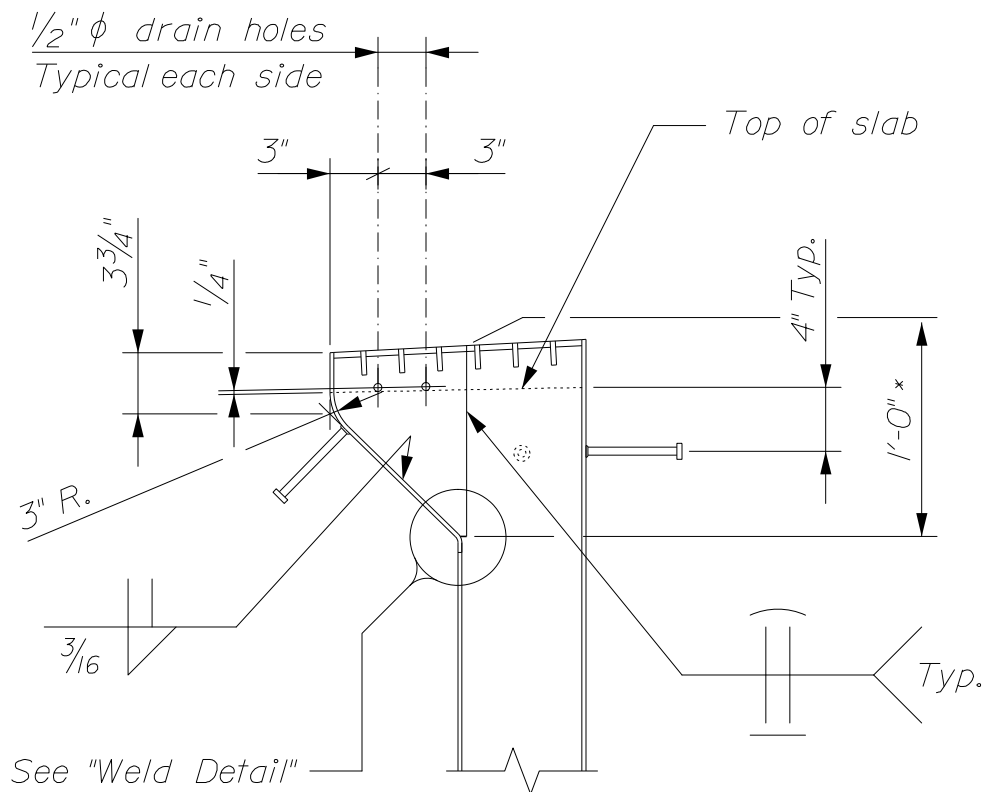

~ DRAIN TYPE "B" SECTION ~

1'-0" For 3" Thick H.M.A. Wearing Surface.

0'-9" For A 1" Thick Integral Concrete Wearing Surface.

## BRIDGE DRAINS

502(20)

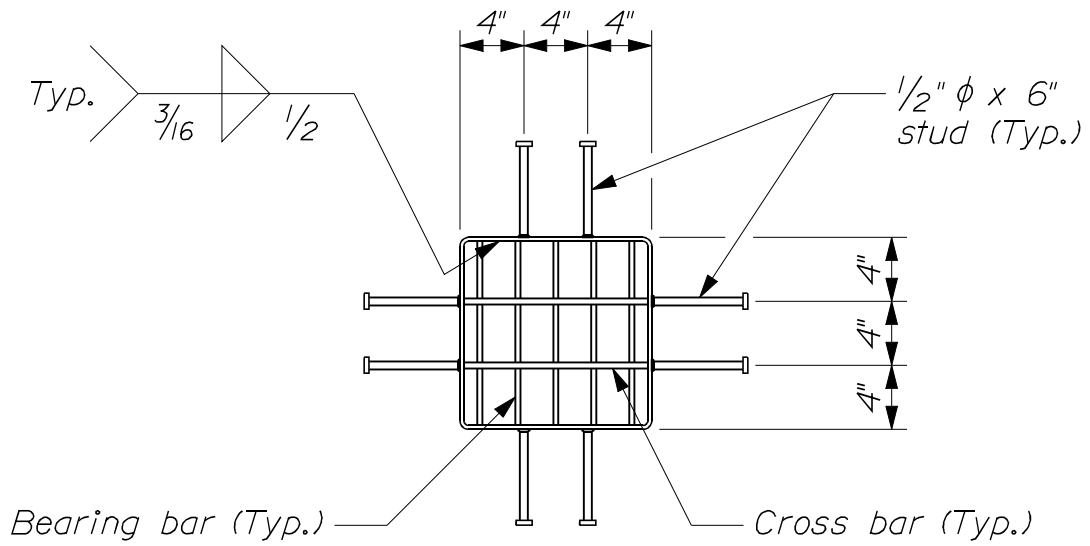

~ DRAIN TYPE "C" TOP VIEW ~

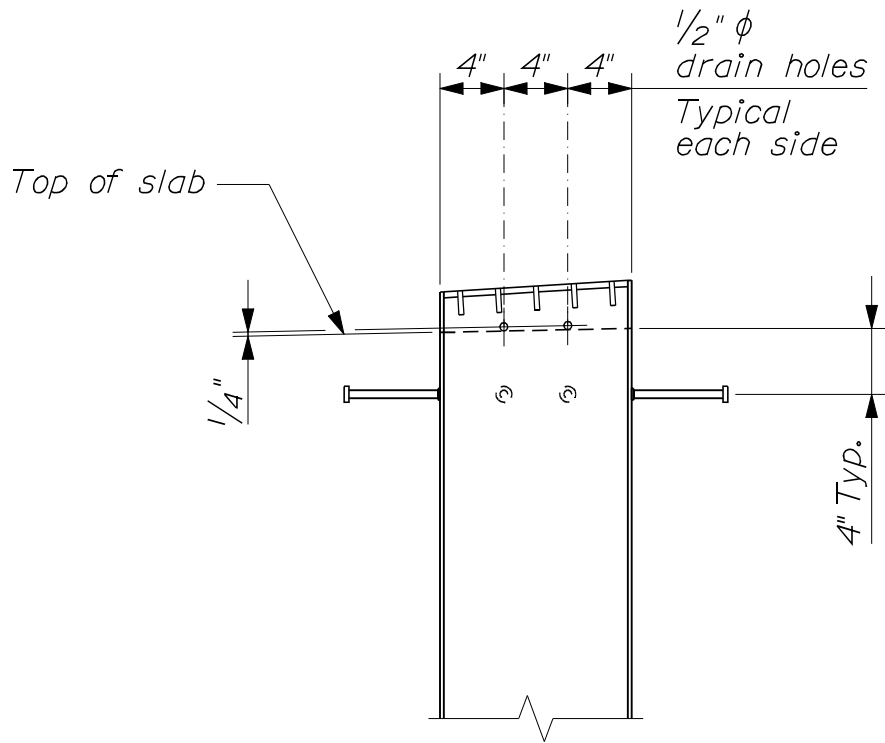

~ DRAIN TYPE "C" SECTION ~

BRIDGE DRAINS  
 502(21)

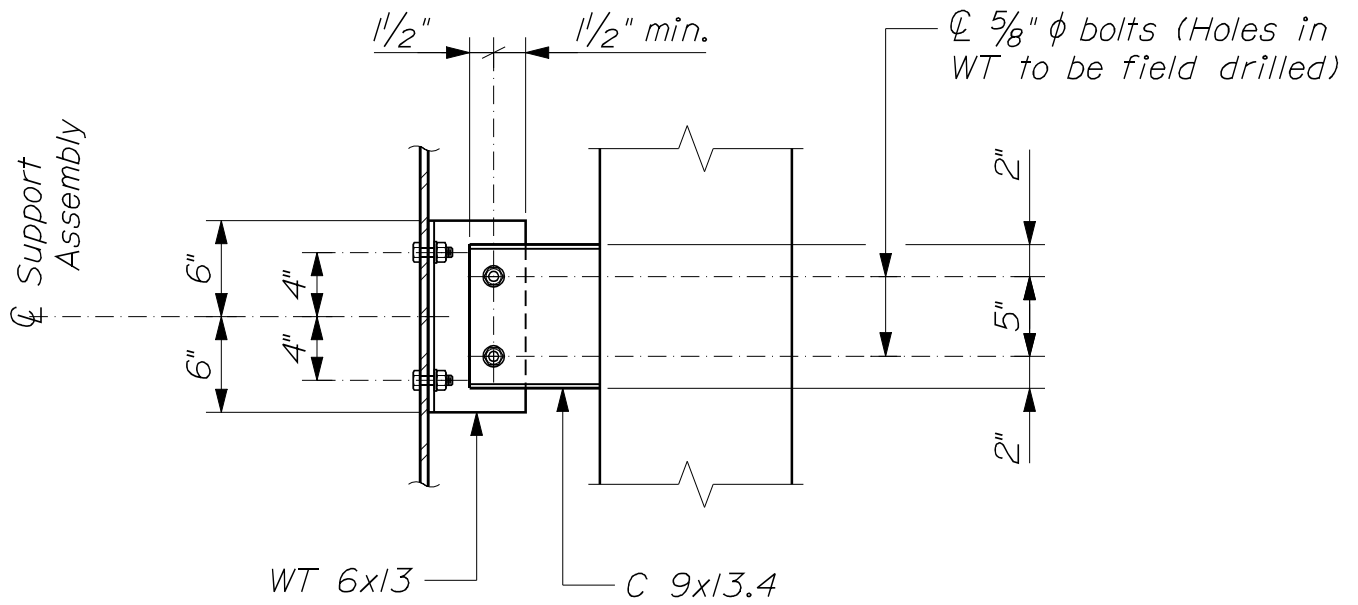

~ SUPPORT ASSEMBLY DETAIL ~

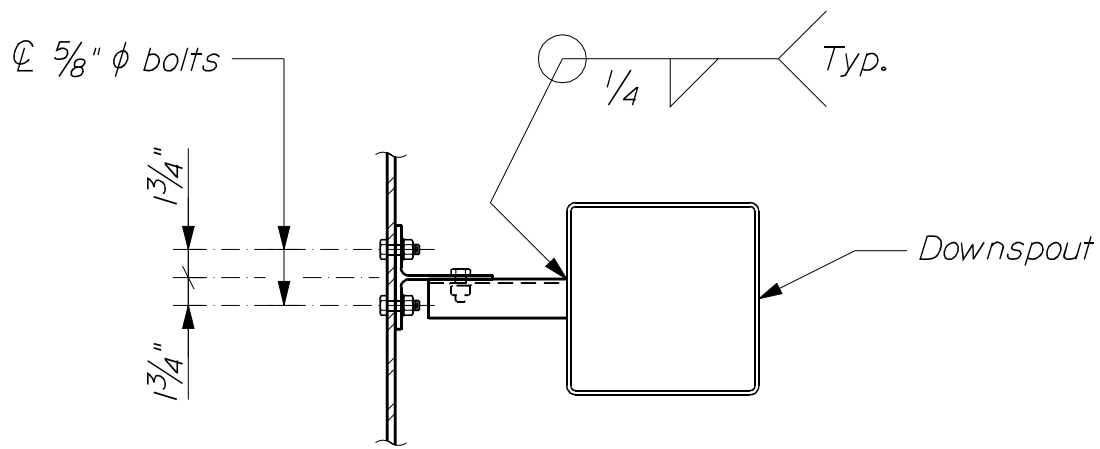

~ SUPPORT ASSEMBLY TOP VIEW ~

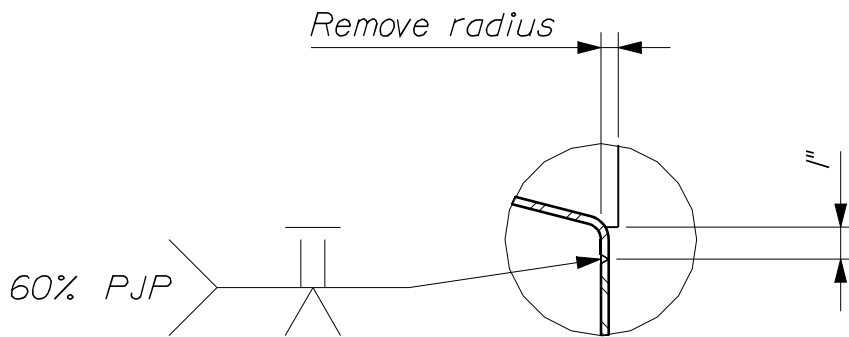

~ WELD DETAIL ~

BRIDGE DRAINS  
502(22)

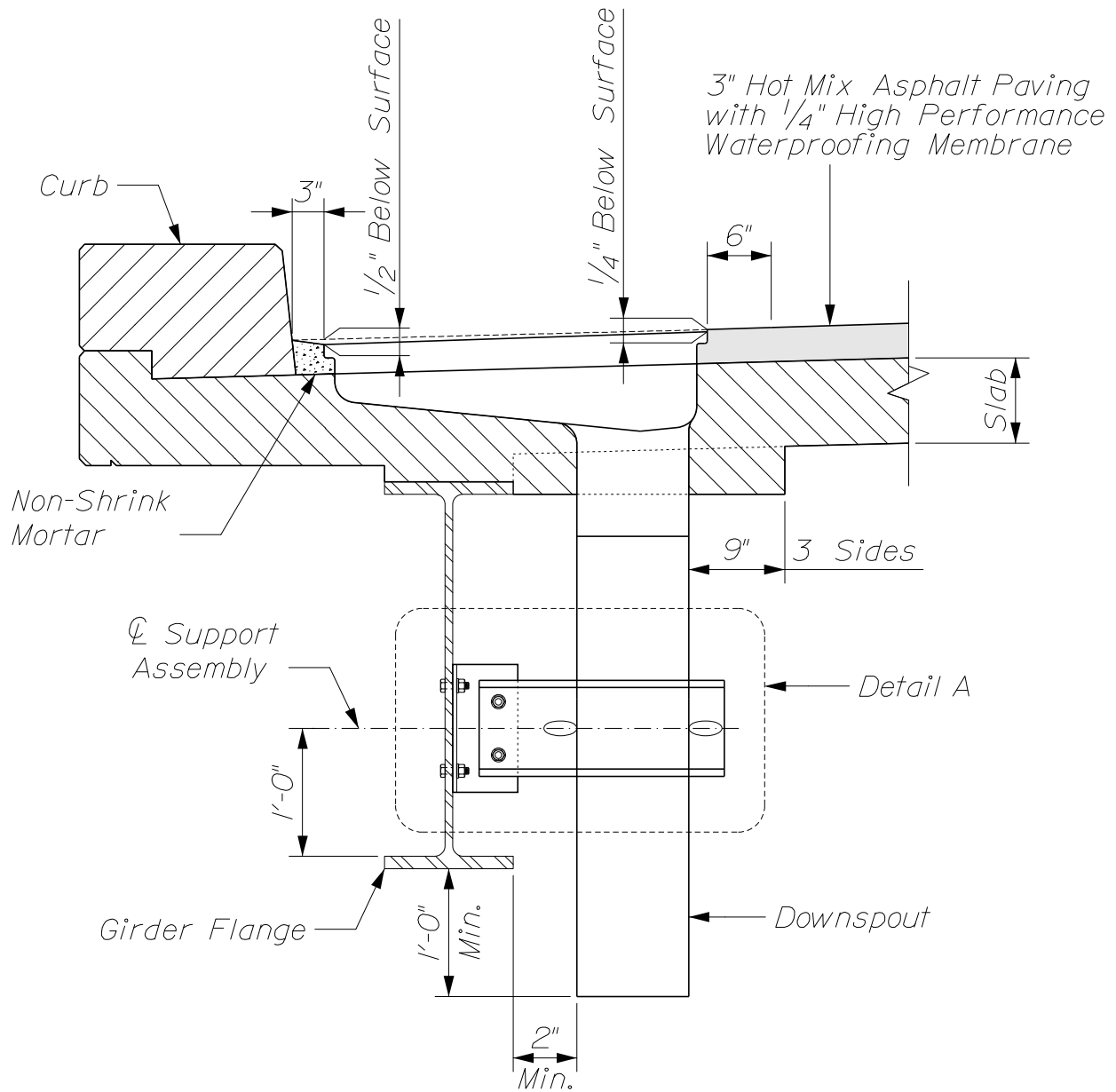

**NOTE:**

FRP Bridge Drains shall be designed and detailed based on the information contained in the Plans and in accordance with Special Provision Section 502, Fiber Reinforced Polymer Bridge Drains and Downspouts.

~ BRIDGE DRAIN "FRP" ELEVATION ~

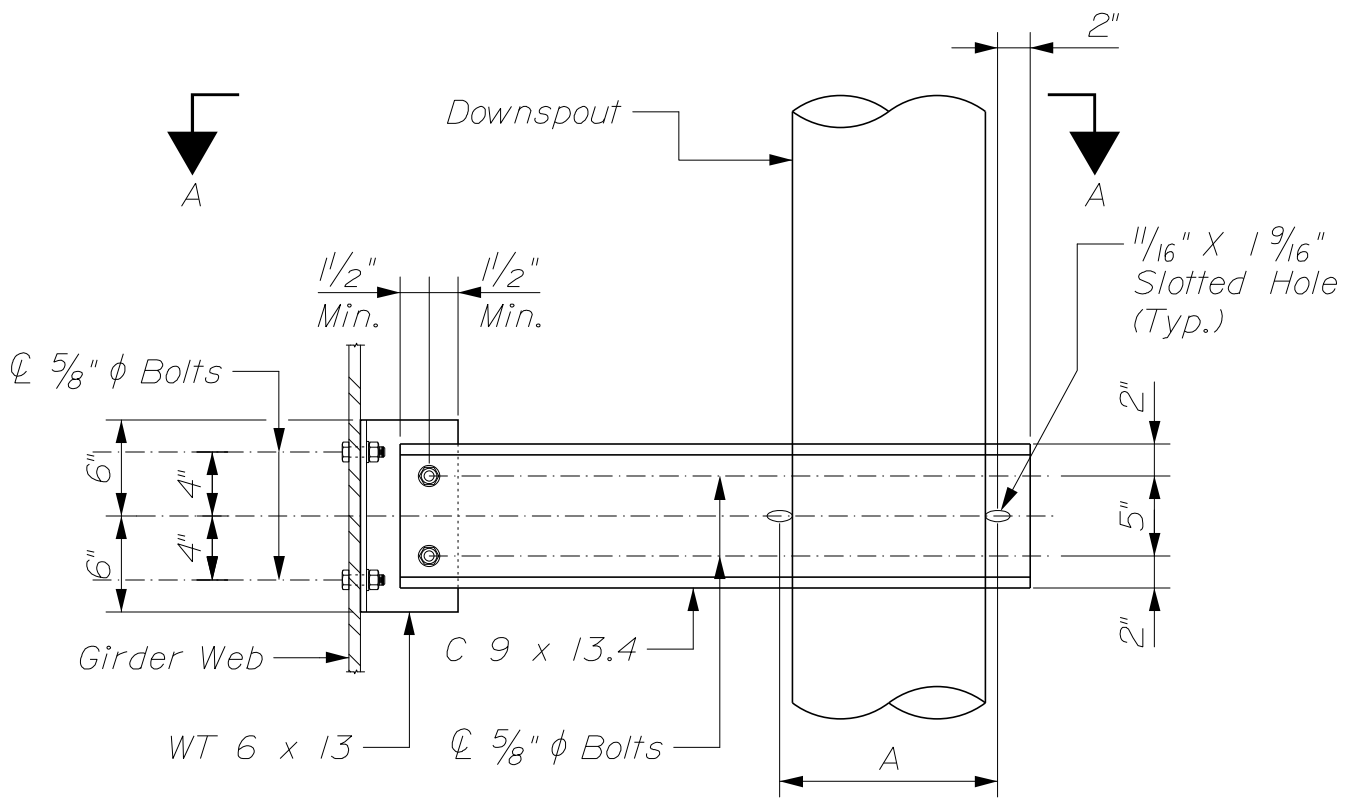

DETAIL A

"A" Dimension =  
Downspout Outer Diameter Plus  $5/8$ "  
Plus  $1/4$ " Tolerance

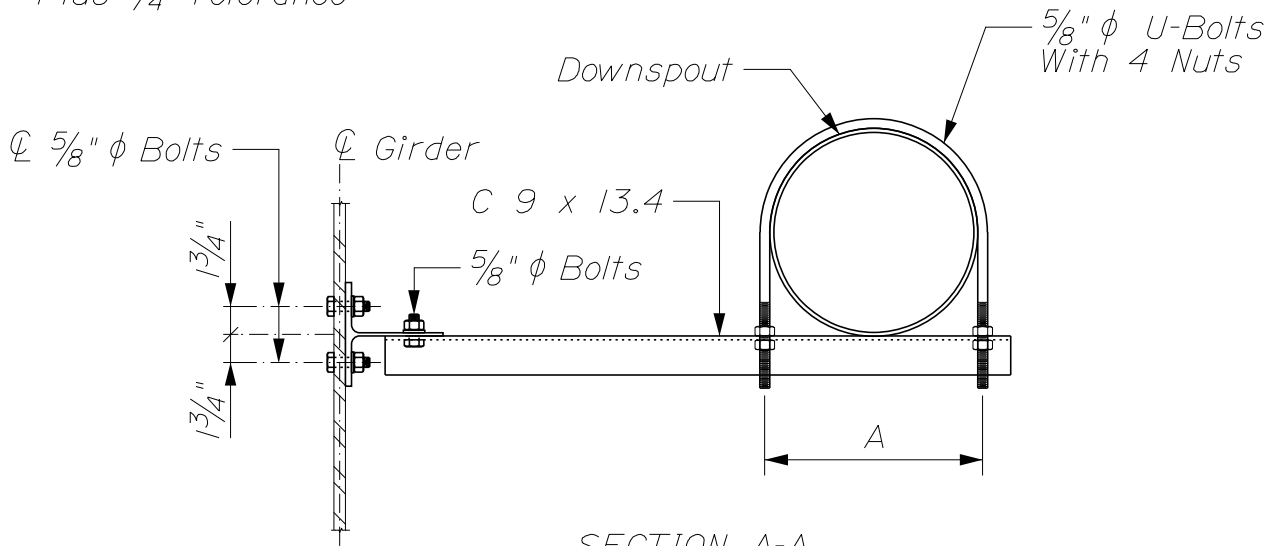

SECTION A-A

~ BRIDGE DRAIN "FRP" DETAILS ~

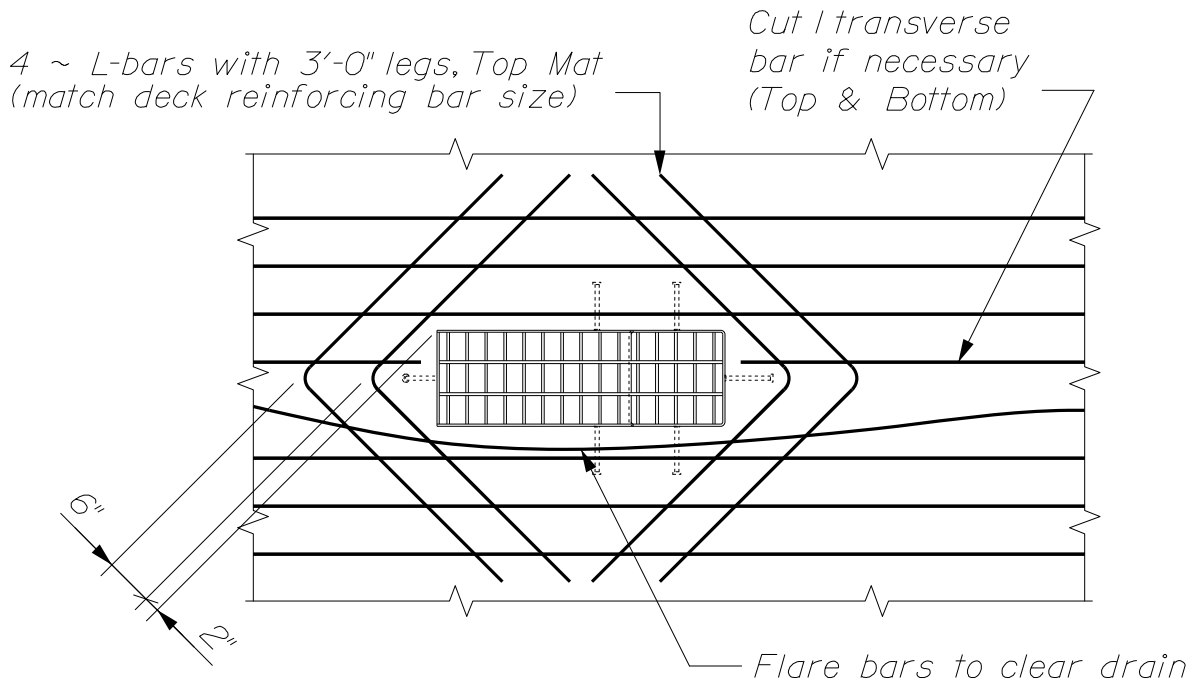

~ SLAB REINFORCING PLAN - LONG PAN DRAINS ~

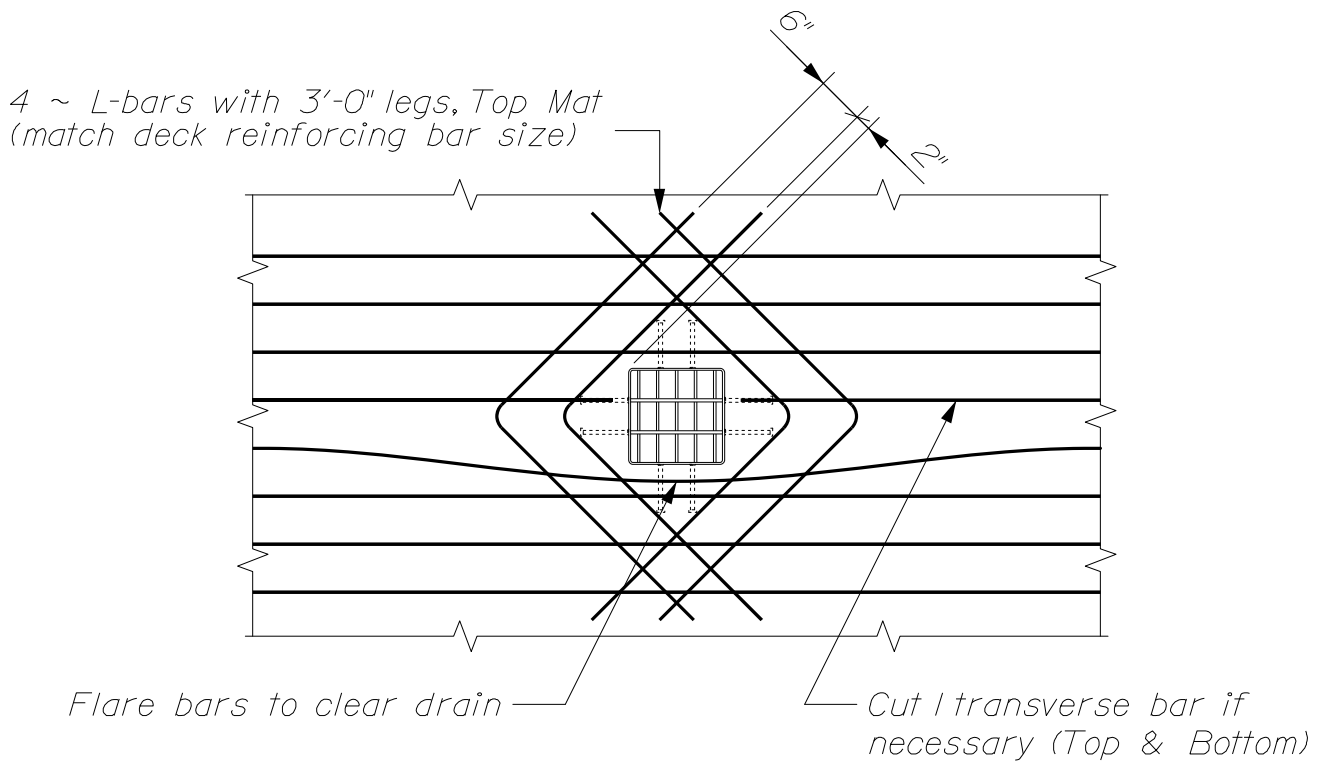

~ SLAB REINFORCING PLAN - SHORT PAN DRAINS ~

BRIDGE DRAINS  
502(25)

## GENERAL NOTES

1. The  $\frac{1}{2}$ " diameter drain holes are not required with concrete wearing surfaces.
2. Except as noted below, the drain support assembly and all associated hardware shall be galvanized in accordance with Standard Specifications Section 506.
3. For weathering or painted steel superstructures, the WT 6x13 shall be coated with a zinc rich coating system in accordance with Standard Specifications Section 506. Bolts in contact with weathering steel shall be Type 3. Nuts and washers shall be treated in the same manner as their associated bolt.
4. Shear connectors welded to the top flange of steel beams may require adjustment to clear the bridge drains.
5. If the minimum thickness of concrete below the drain pan is 2 inches or less, the concrete haunch shall be extended as shown.
6. For drains installed on bridges with one-inch thick integral concrete wearing surfaces, the drain pan depth shall be reduced from 1'-0" to 0'-9".
7. Payment for bridge drains will be as specified under Subsection 502.19 of the Standard Specifications unless a specific pay item is provided in the Contract.
8. Payment for adjusting and for providing the additional reinforcing at bridge drains will be considered incidental to related Contract items.

## STEEL DRAIN NOTES

1. All plates shall be  $\frac{1}{4}$ " inch thick.
2. The grating shall be a commercial heavy-duty grating with  $1\frac{1}{2}$ " x  $\frac{5}{16}$ " bearing bars spaced at  $2\frac{3}{8}$ " and  $\frac{3}{8}$ " diameter cross bars spaced at 4". The grating shall be centered in the drain top.

## MATERIALS

Shapes & plates.....	AASHTO M 270M/M 270
Bolts, nuts & washers.....	ASTM F3125, ASTM A563 & ASTM F436
Stud/shear connectors.....	AASHTO/AWS DI.5, Type A
Steel Drain Downspout.....	ASTM A500

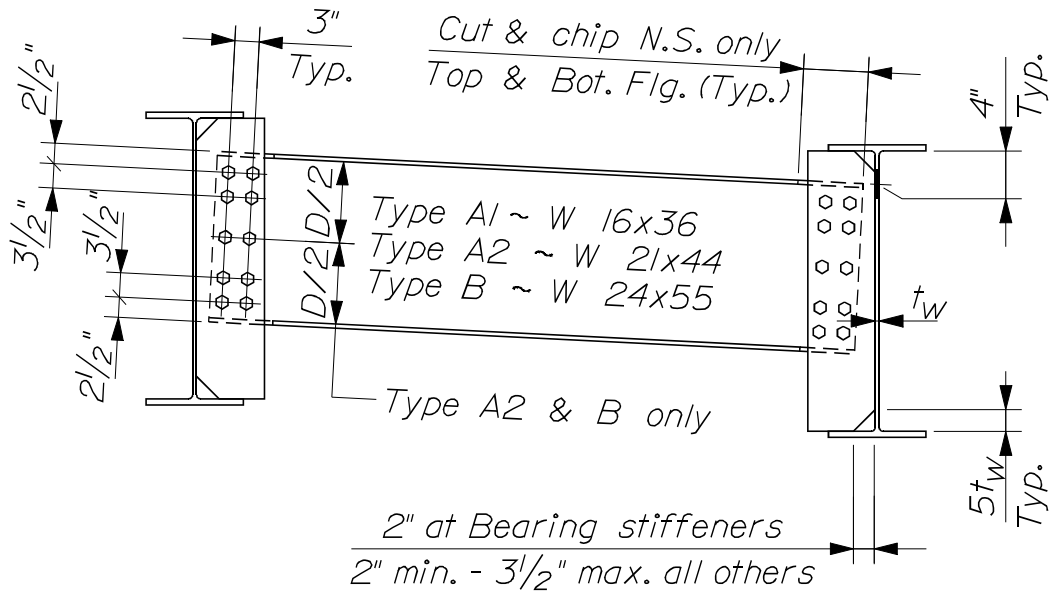

~ TYPE A1, A2, & B ~

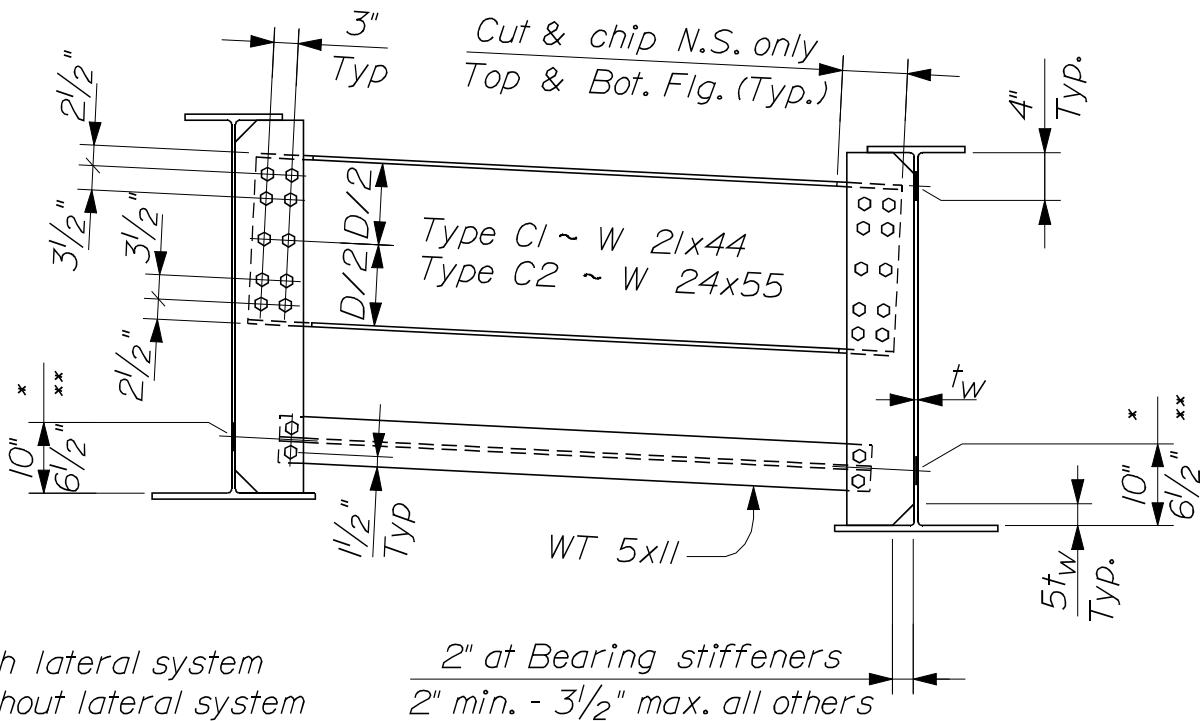

\* with lateral system  
\*\* without lateral system

~ TYPE C1 & C2 ~

DIAPHRAGMS  
504(01)

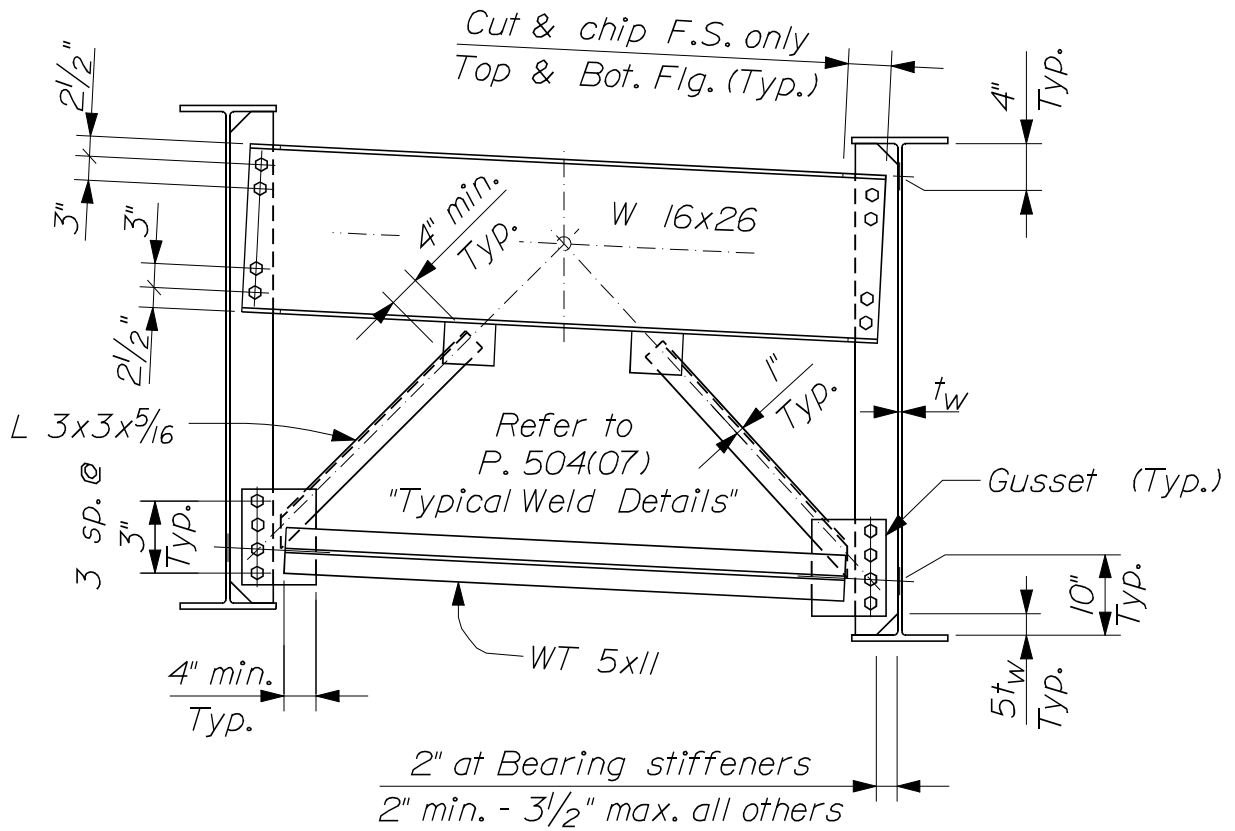

~ TYPE D ~

Dimension "A" shall be approximately equal to but not greater than dimension "B". Neither dimension shall be less than 3 1/2".

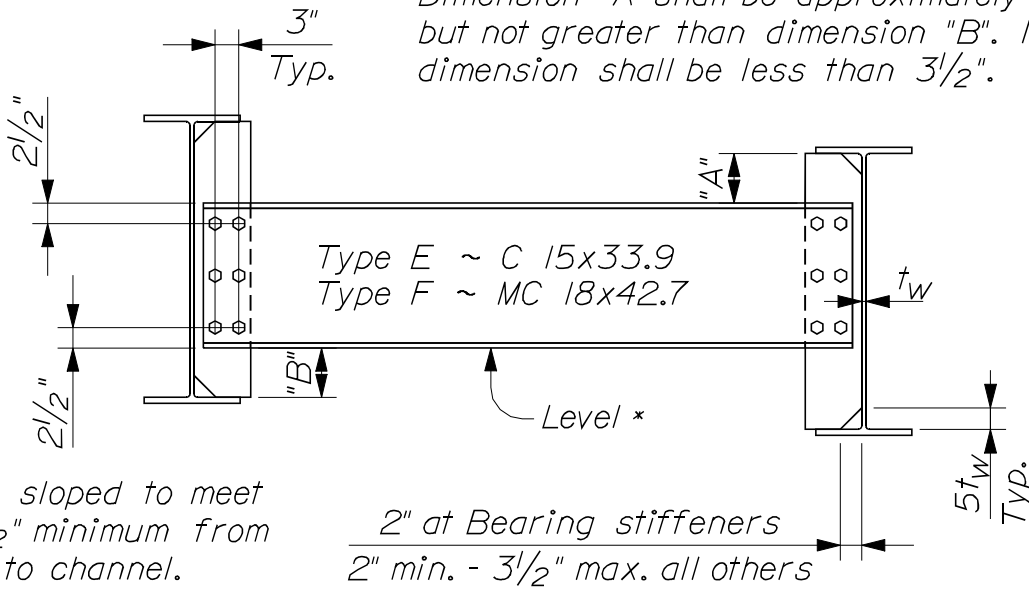

\* May be sloped to meet the 3 1/2" minimum from flange to channel.

~ TYPE E & F ~

DIAPHRAGMS  
504(02)

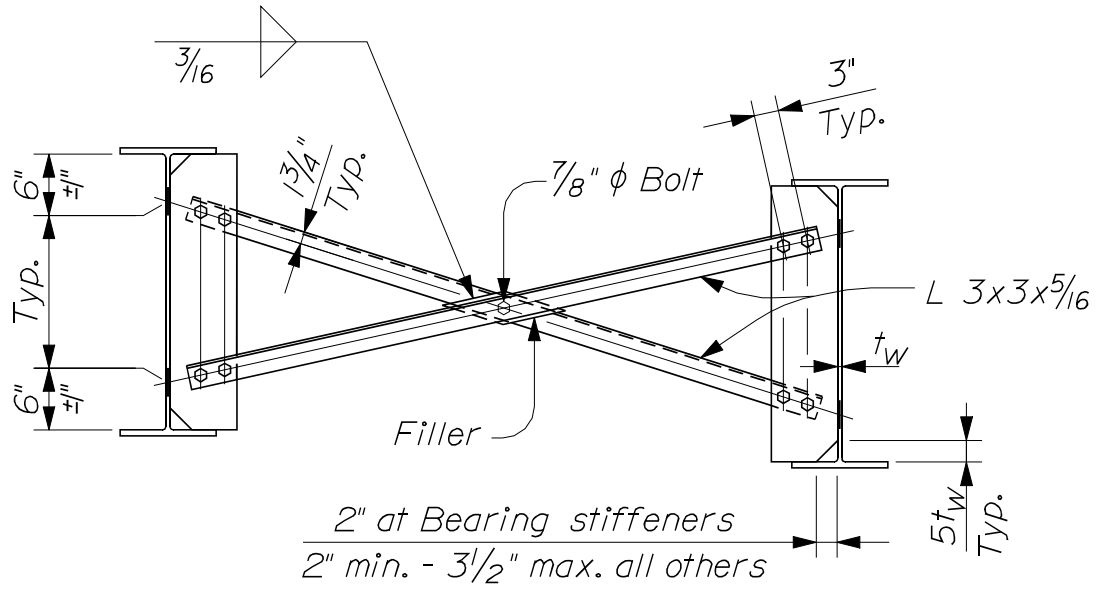

~ TYPE G ~

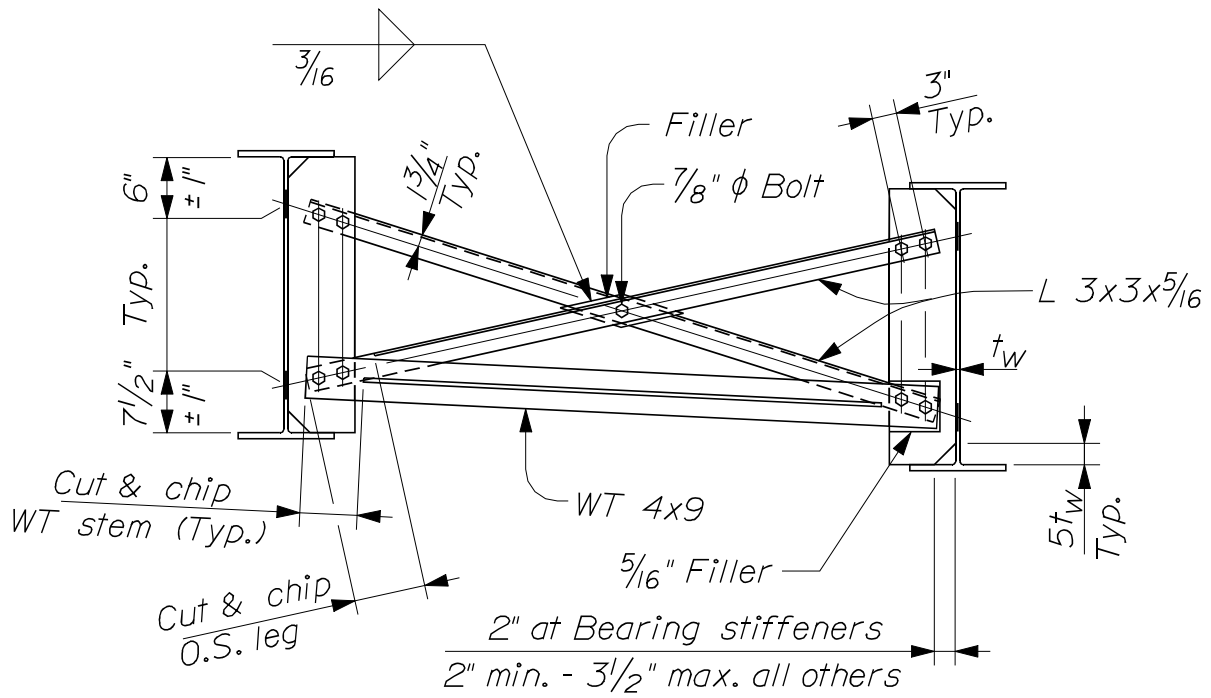

~ TYPE H ~

CROSSFRAMES  
504(03)

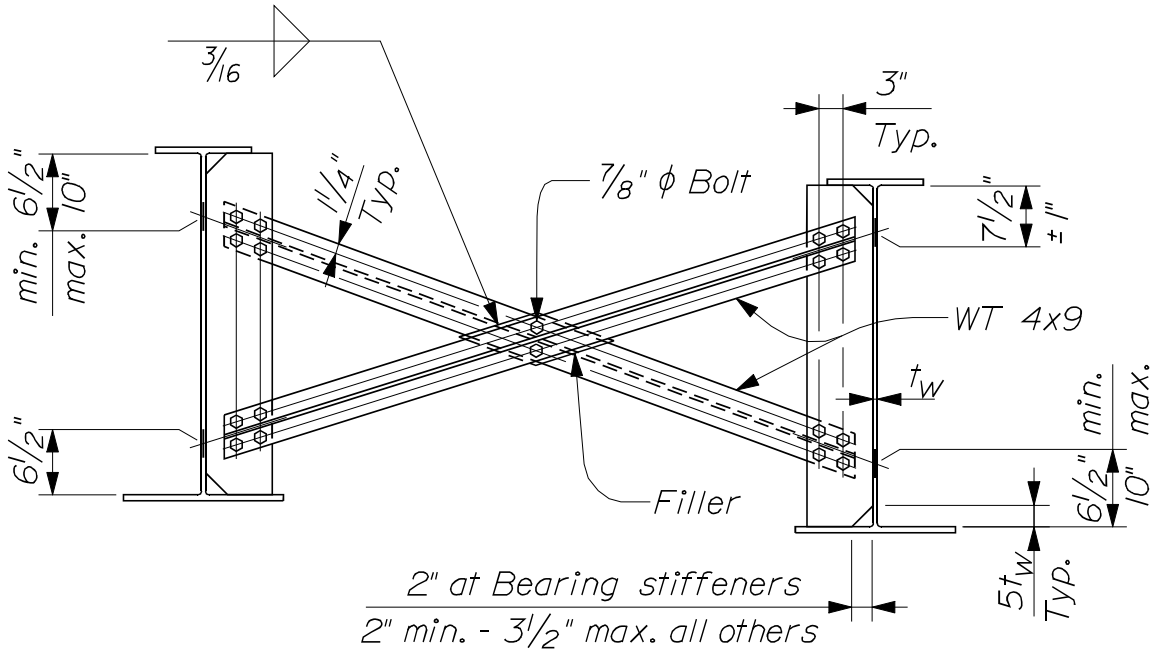

~ TYPE J ~

Refer to P. 504(07)  
"Typical Weld Details"

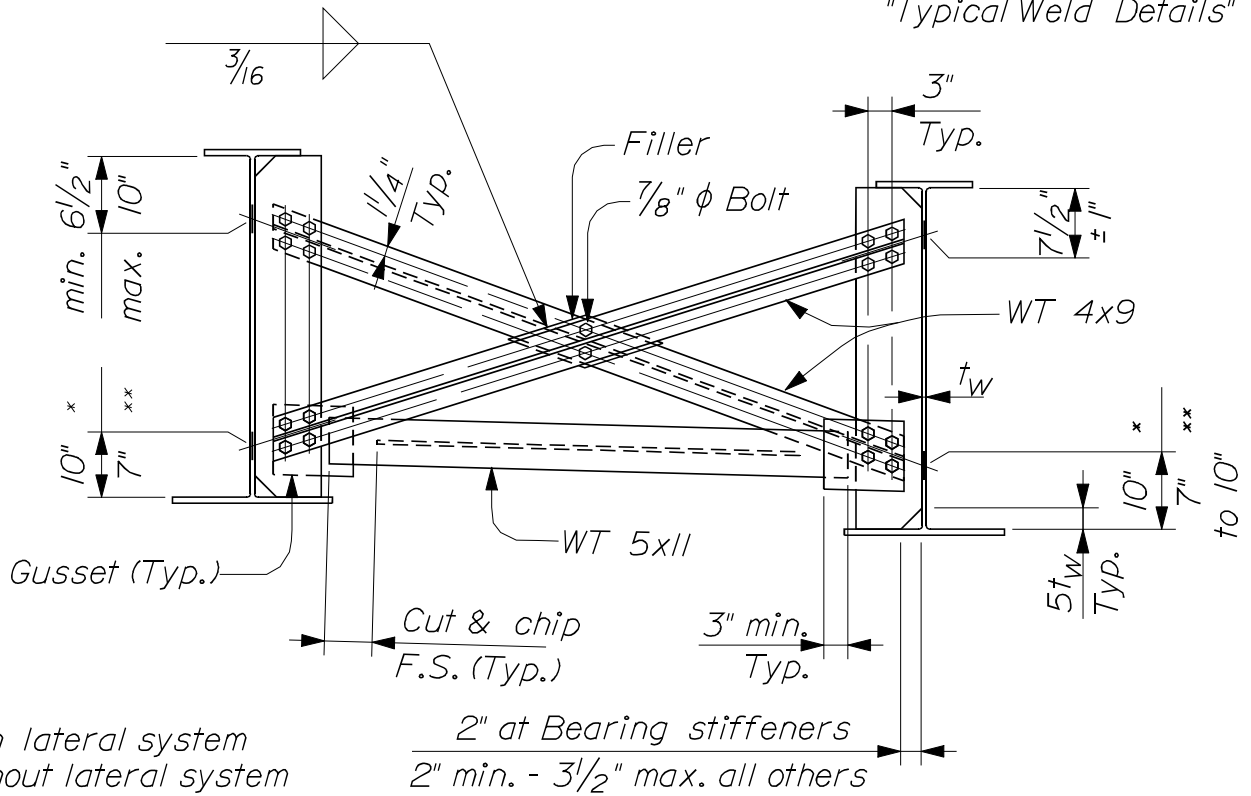

\* with lateral system  
\*\* without lateral system

~ TYPE K ~

CROSSFRAMES  
504(04)

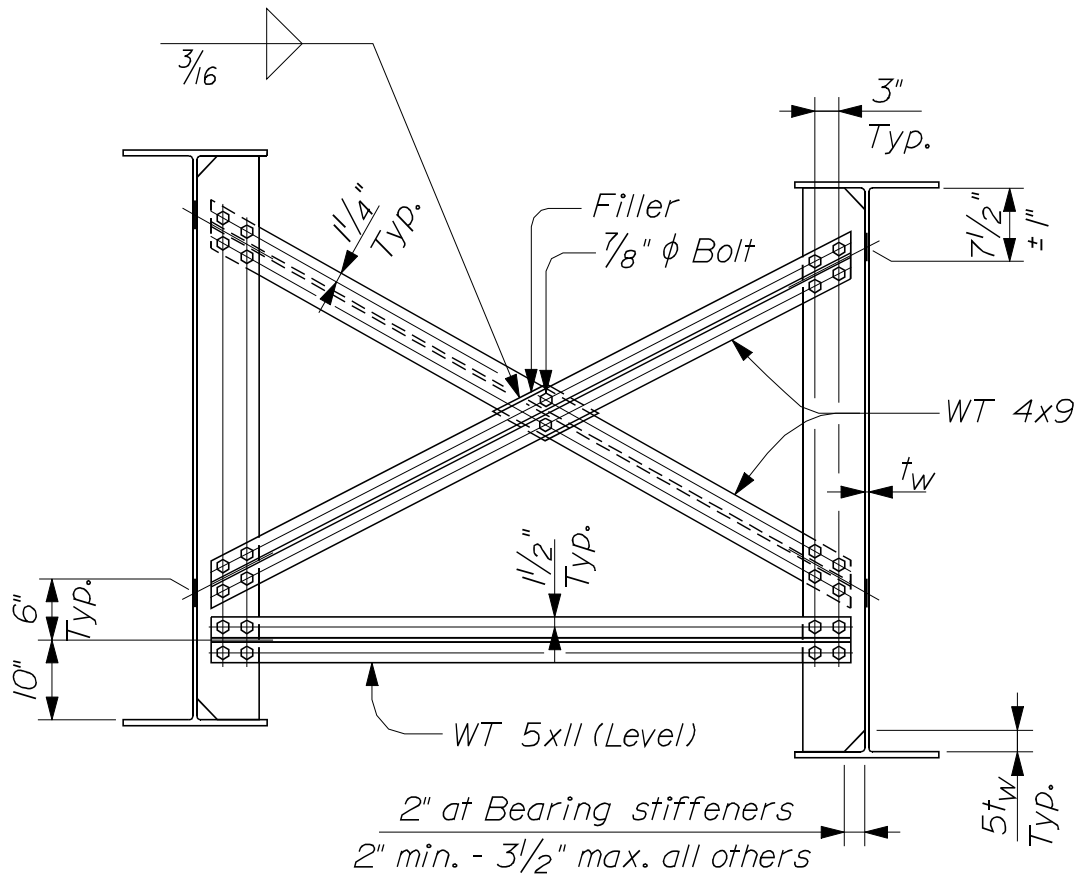

~ TYPE L ~

CROSSFRAMES  
504(05)

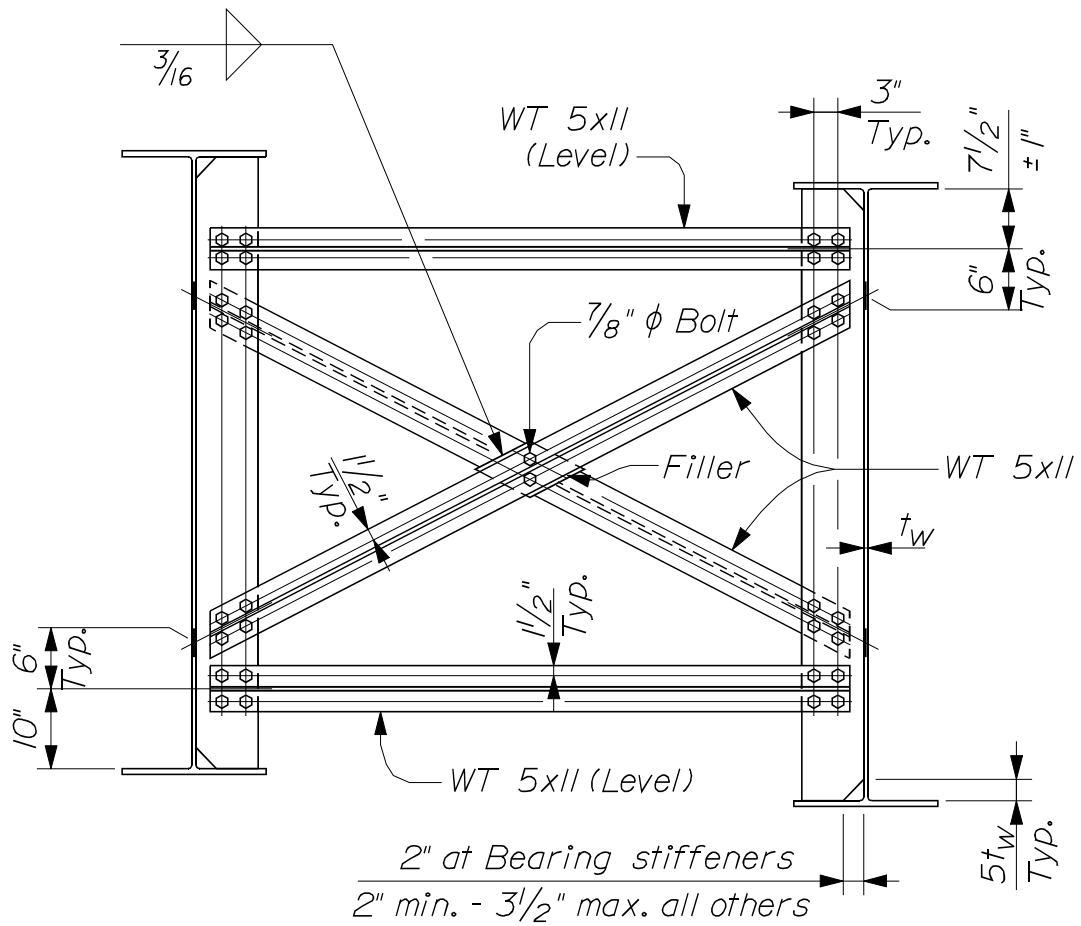

~ TYPE M ~

# CROSSFRAMES

504(06)

NOTES:

1. Steel for diaphragms, crossframes, connection plates, gussets and stiffeners shall be as designated on the Plans.
2. All welds for diaphragms, crossframes, connection plates, gussets and stiffeners shall terminate  $\frac{5}{8}$ "  $\pm$   $\frac{1}{8}$ " from the ends of the plates.
3. Bolts shall be  $\frac{7}{8}$ " diameter. Bolt holes shall be  $\frac{15}{16}$ " diameter. The minimum edge distance shall be  $1\frac{1}{2}$ " unless otherwise shown on the Plans. Oversized or short-slotted holes may only be used with the permission of the Fabrication Engineer.
4. Connection plates and gussets shall be  $\frac{3}{8}$ " minimum thickness. Connection plates shall be 7" minimum width and full web depth, and they shall be tight fit to both flanges.
5. The plate thickness for stiffeners and bent connection plates shall be as shown on the Plans.
6. The bearing ends of bearing stiffeners shall be flush and square with the web and shall have at least 75% of the bearing end area in contact with the flanges within the tolerances allowed by the latest edition of the AWS D1.5 welding code.
7. Intermediate stiffeners shall be tight fit to both flanges. Intermediate stiffeners used as connection plates shall be detailed as connection plates.
8. Connection plates and stiffeners used as connection plates shall be welded to the web and flanges on both sides of the plates.

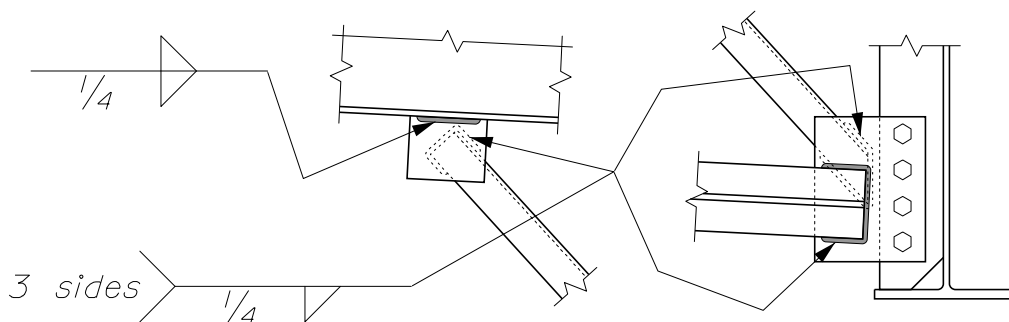

~ TYPICAL WELD DETAILS ~

DIAPHRAGM & CROSSFRAME NOTES

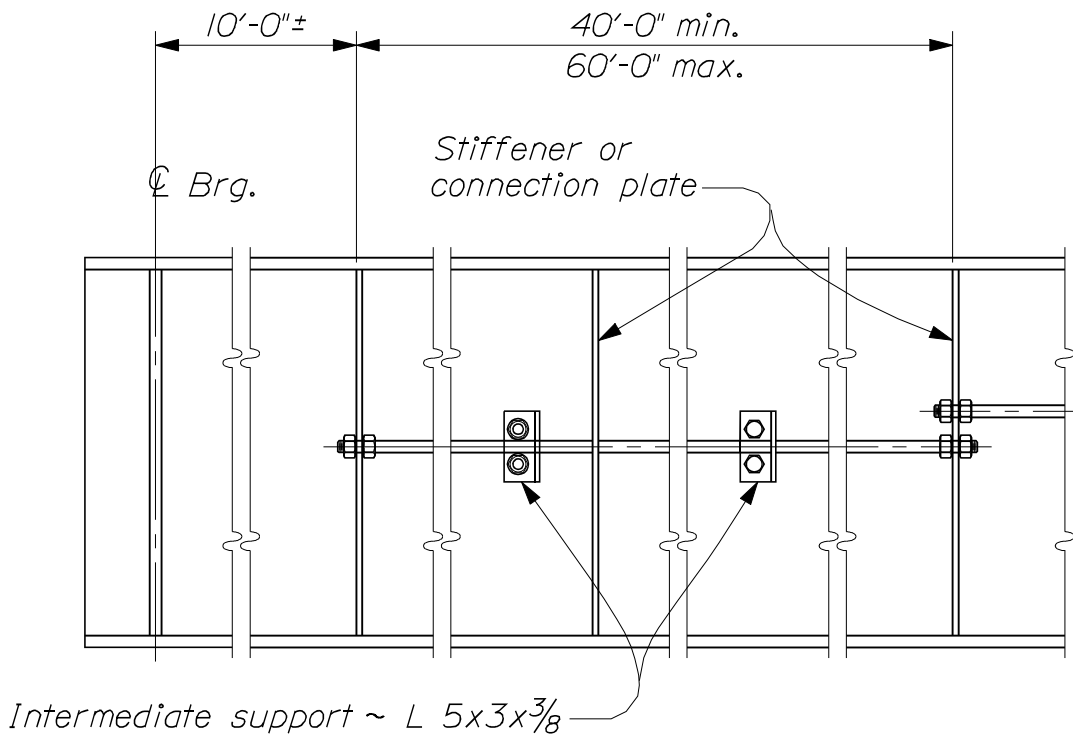

~ ELEVATION ~

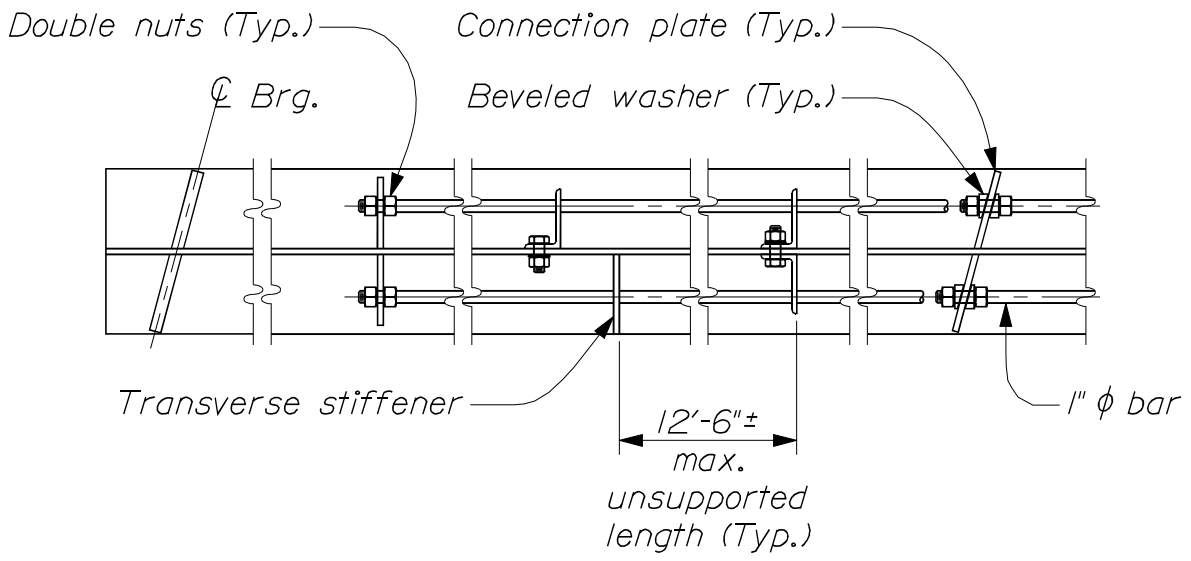

~ PLAN ~

HAND - HOLD DETAILS  
504(08)

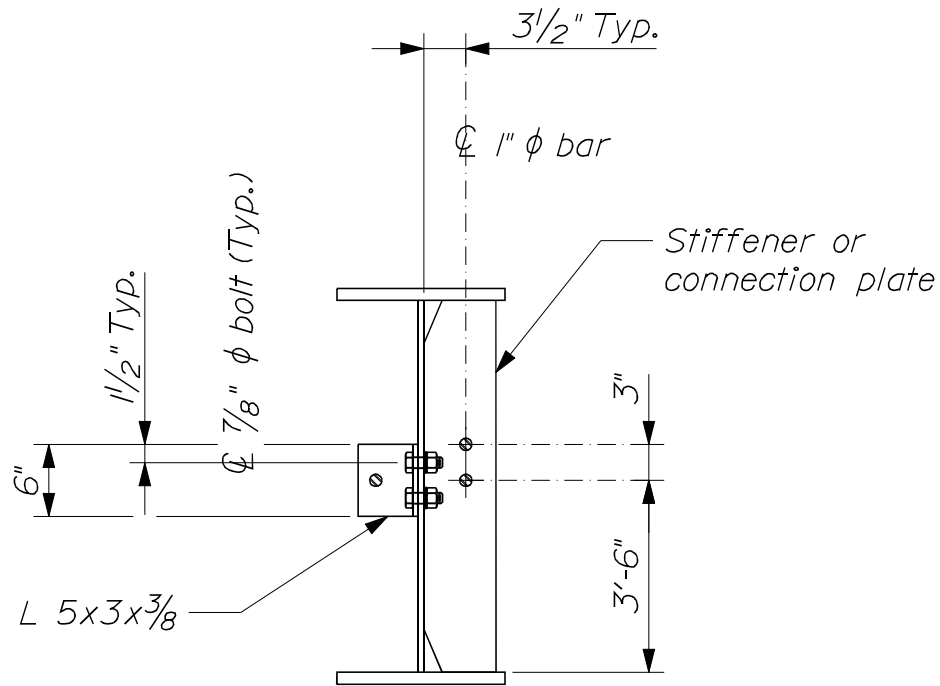

~ TYPICAL SECTION ~

**NOTES:**

1. Hand - hold bars shall be installed on the inside of exterior beams and on both sides of interior beams when called for on the Design Drawings.
2. Termination and splicing of hand - hold bars shall occur at stiffeners or connection plates. Angle supports shall be used at intermediate locations only. All termination and splice plates shall be a minimum of 1/2 inch thick. Additional stiffeners shall be provided where necessary to meet the described requirements.
3. Hole sizes for bolts and hand - hold bars shall be 1/16 inch larger than the bolt / bar size. Edge distances for holes shall be 1 1/2 inches unless otherwise shown.
4. For unpainted applications, the hand - hold bar and nuts shall be galvanized to conform to ASTM M IIIM/M III.

**MATERIALS:**

With unpainted structural steel - All steel.....AASHTO M 270/M 270M, Gr. 50W  
 With painted structural steel - All steel.....AASHTO M 270M/M 270, Gr. 36  
 Heavy hex nuts for 1"  $\phi$  bar .....AASHTO M 291

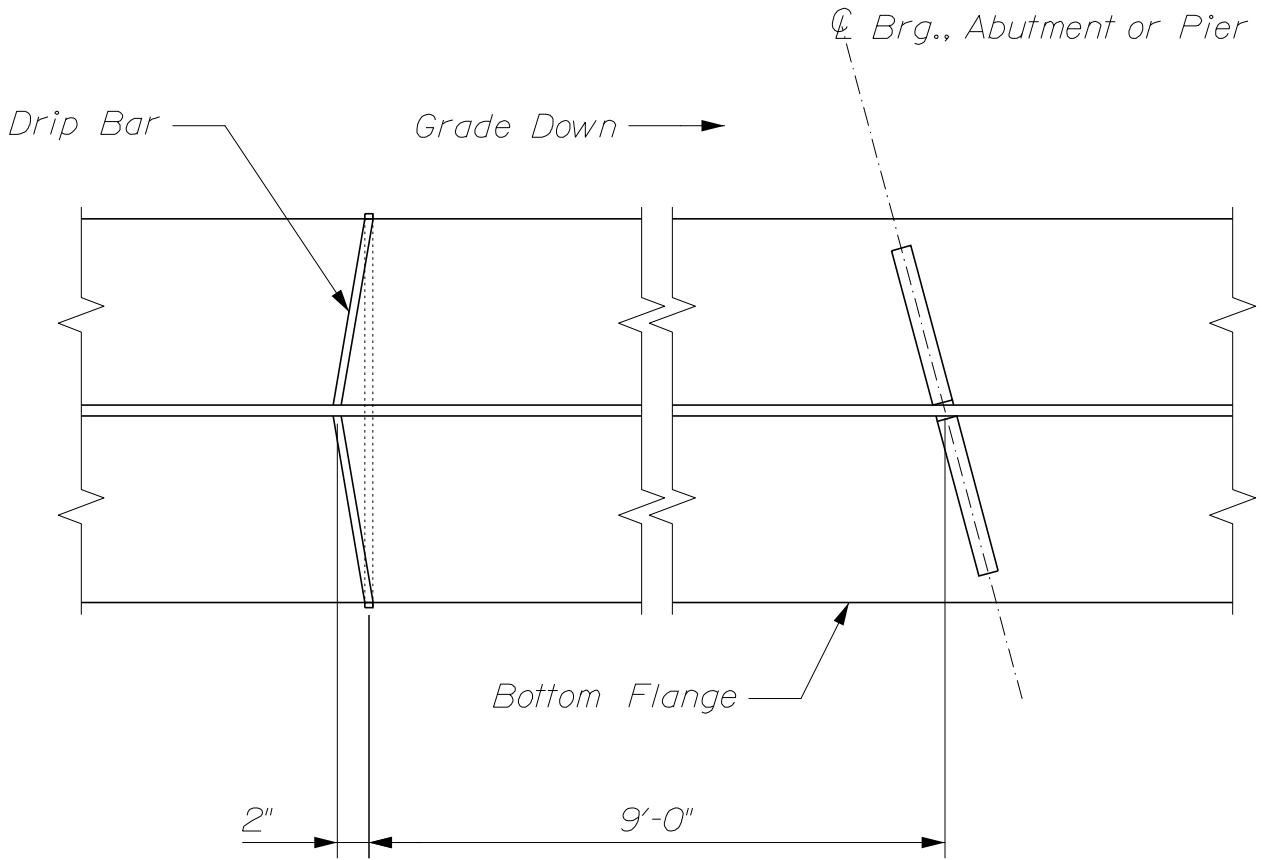

~ DRIP BAR PLAN ~

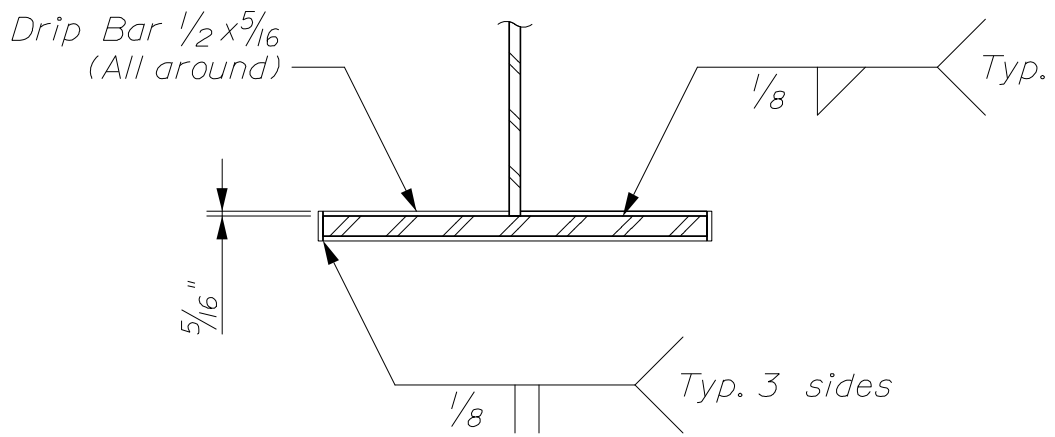

~ DRIP BAR SECTION ~

DRIP BAR DETAILS  
504(10)

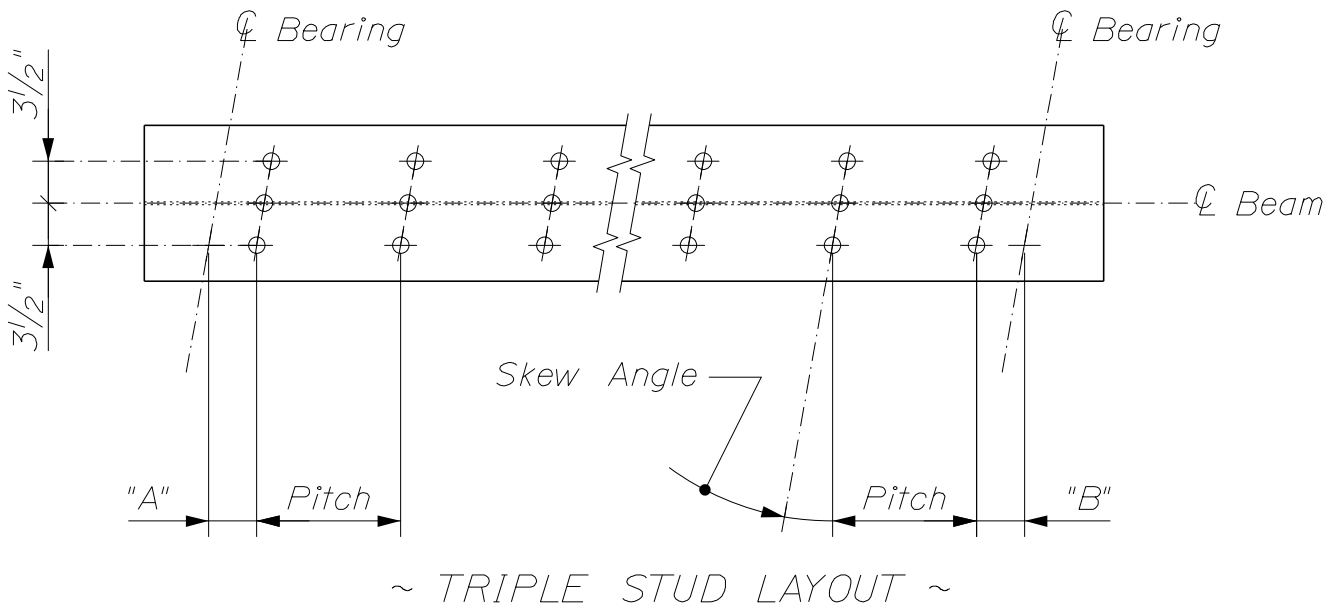
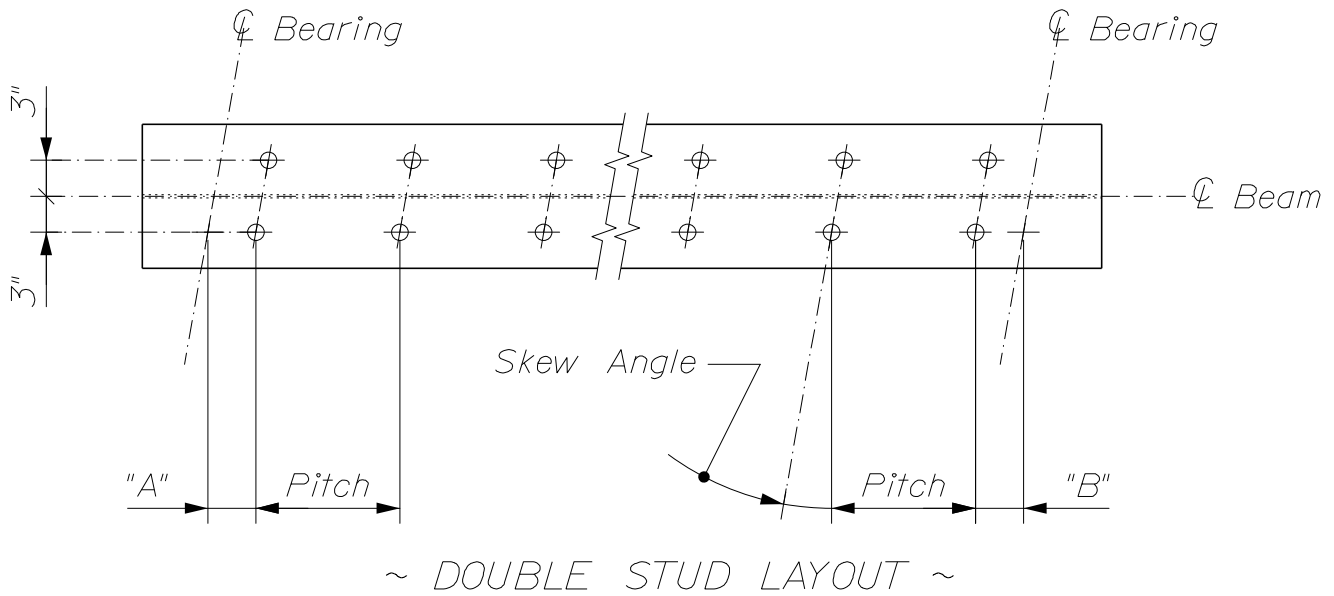

**NOTES:**

1. Refer to Design Drawings for dimensions "A" and "B", stud pitch and skew angle.
2. Studs shall project a minimum of 2" above the bottom of the slab.

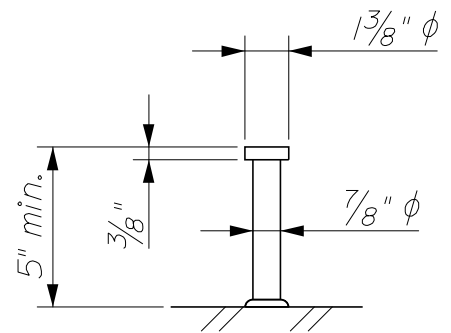

~ STUD DETAIL ~

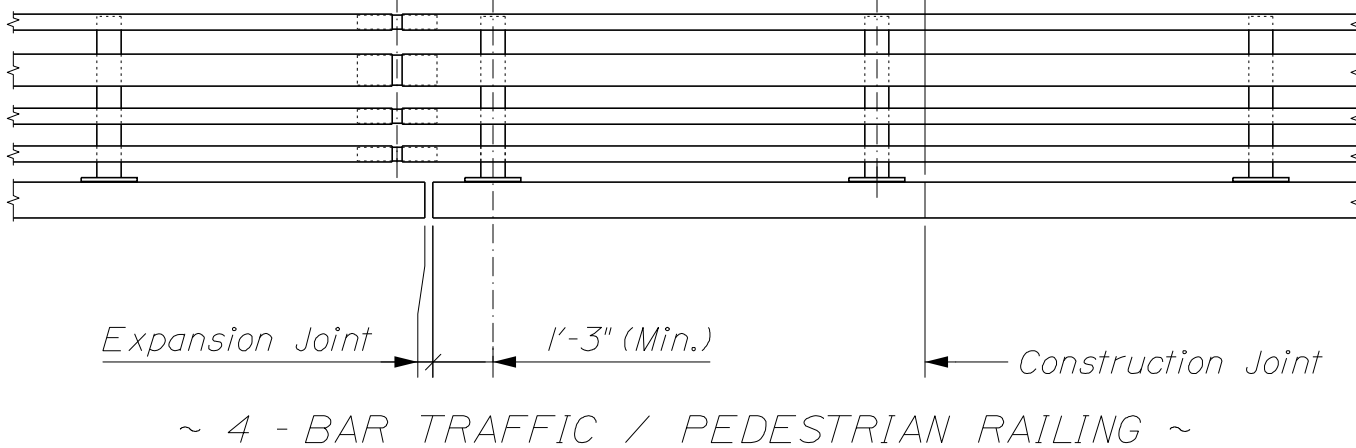
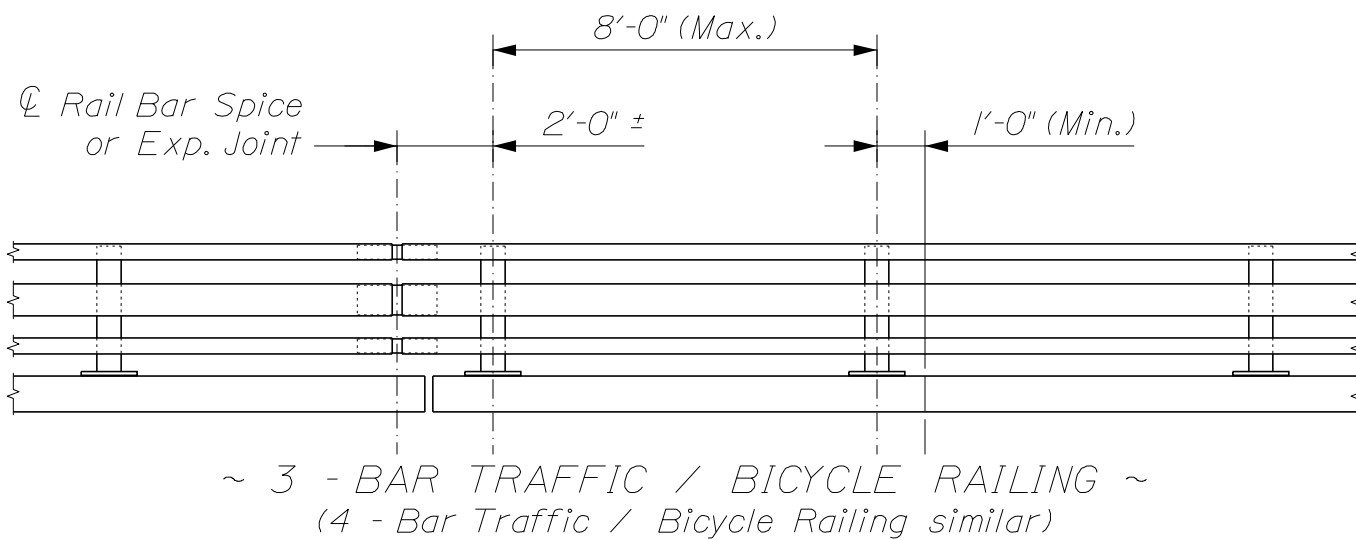
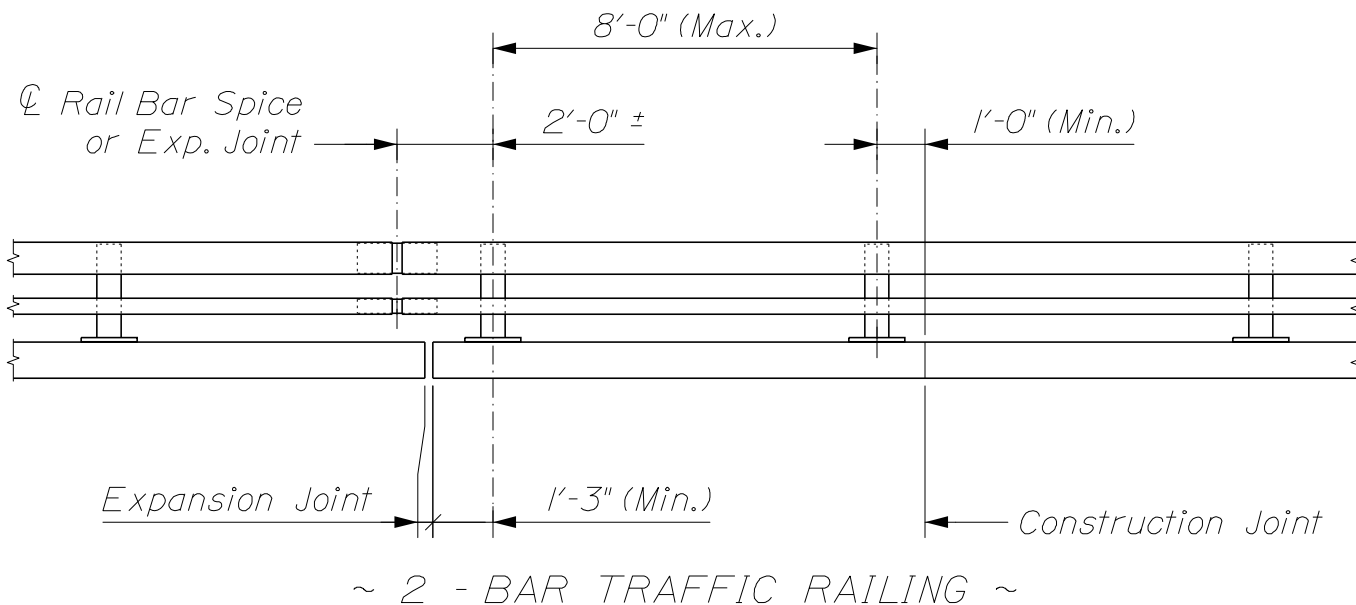

STEEL BRIDGE RAILING  
 507(01)

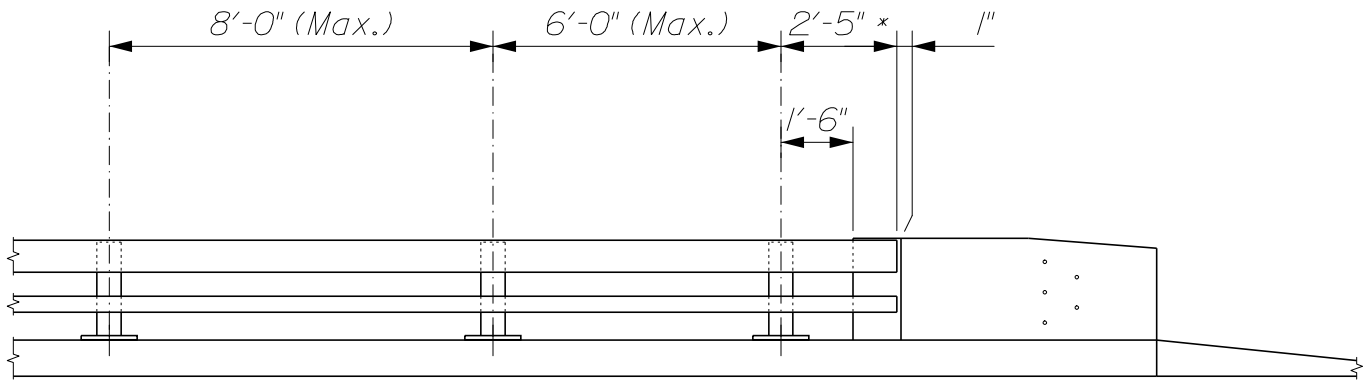

~ 2 - BAR TRAFFIC RAILING ~

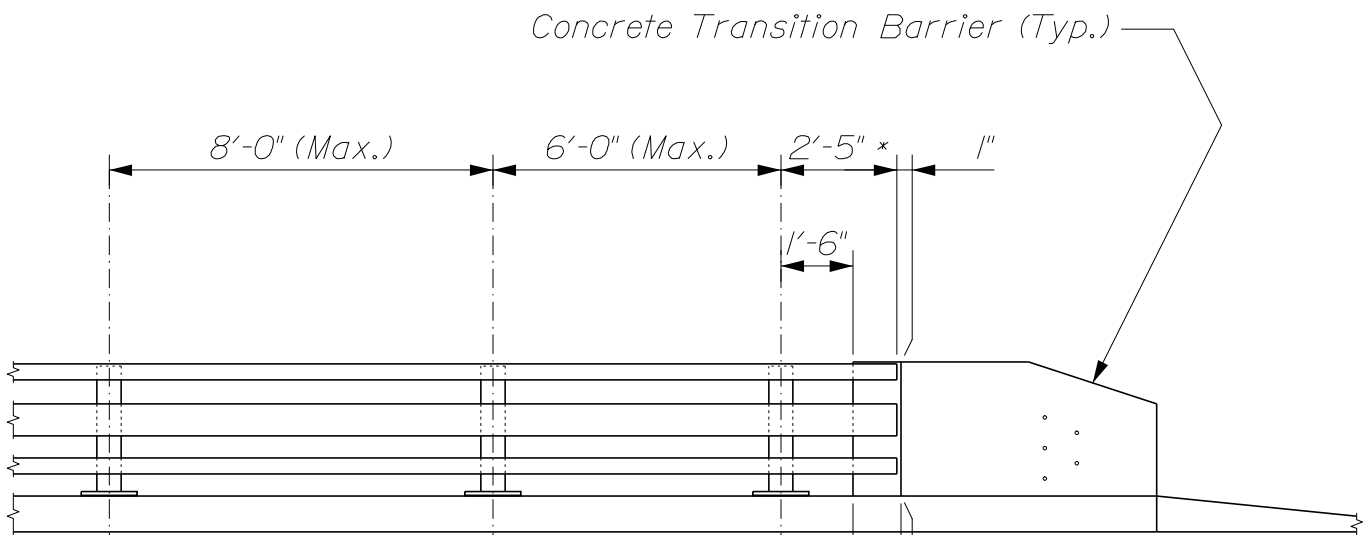

~ 3 - BAR TRAFFIC / BICYCLE RAILING ~  
 (4 - Bar Traffic / Bicycle Railing similar)

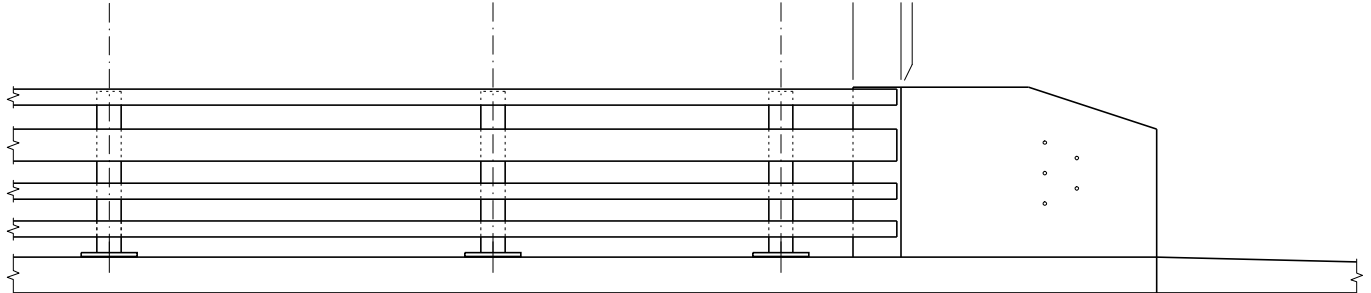

~ 4 - BAR TRAFFIC / PEDESTRIAN RAILING ~

\* Including Rail Bar Cap (Typ.)

STEEL BRIDGE RAILING  
 507(02)

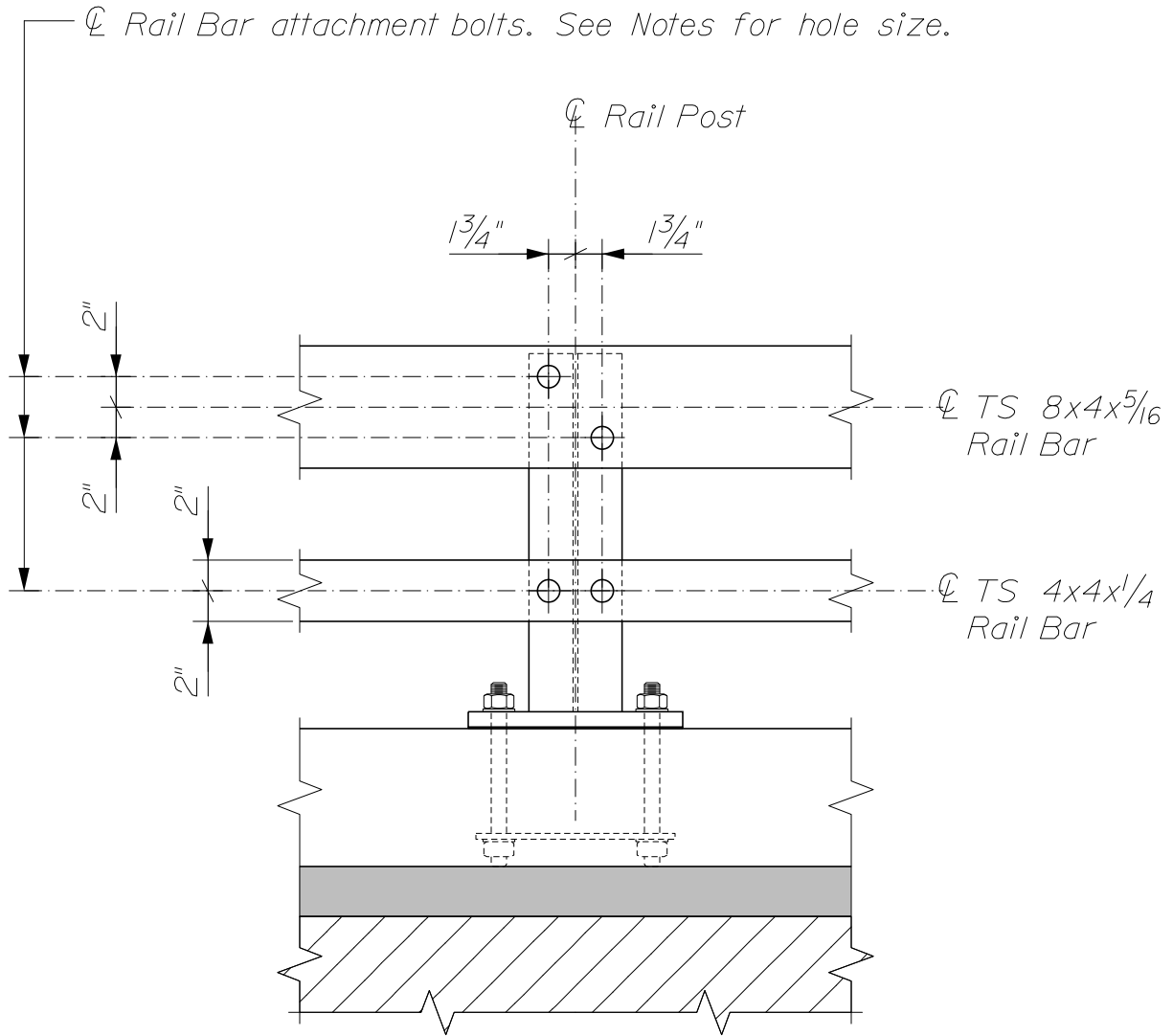

~ TYPICAL RAILING ELEVATION ~  
 2 - Bar Traffic Railing is shown.  
 Other railing configurations are similar.

STEEL BRIDGE RAILING  
 507(03)

Rail Bars:  
 HSS 8x4x $\frac{5}{16}$  (1)  
 HSS 4x4x $\frac{1}{4}$  (1)

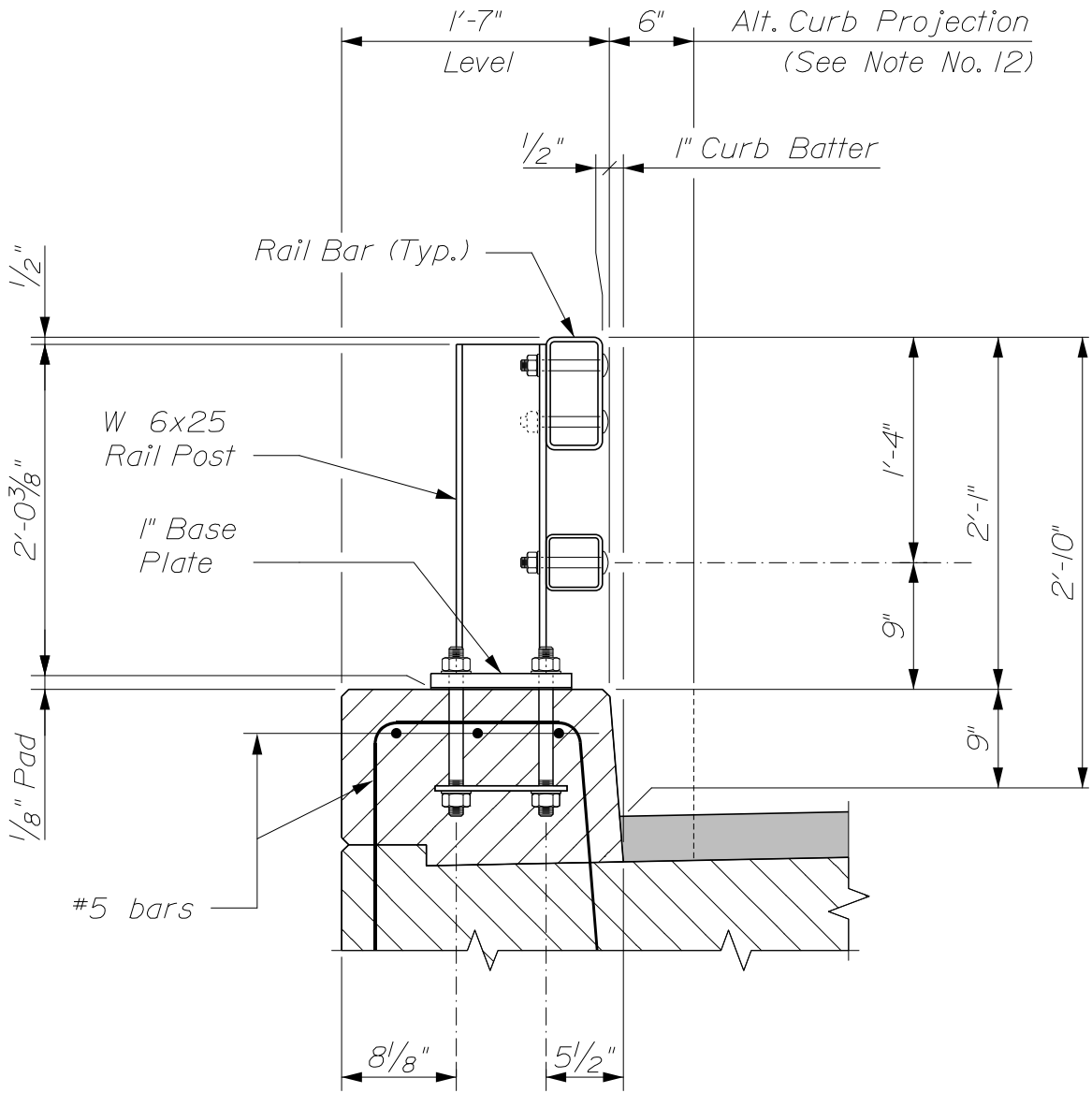

~ TYPICAL RAILING SECTION ~  
 (2 - Bar Traffic Railing)

STEEL BRIDGE RAILING  
 507(04)

Rail Bars:  
 HSS 8x4x $\frac{5}{16}$  (1)  
 HSS 4x4x $\frac{1}{4}$  (2)

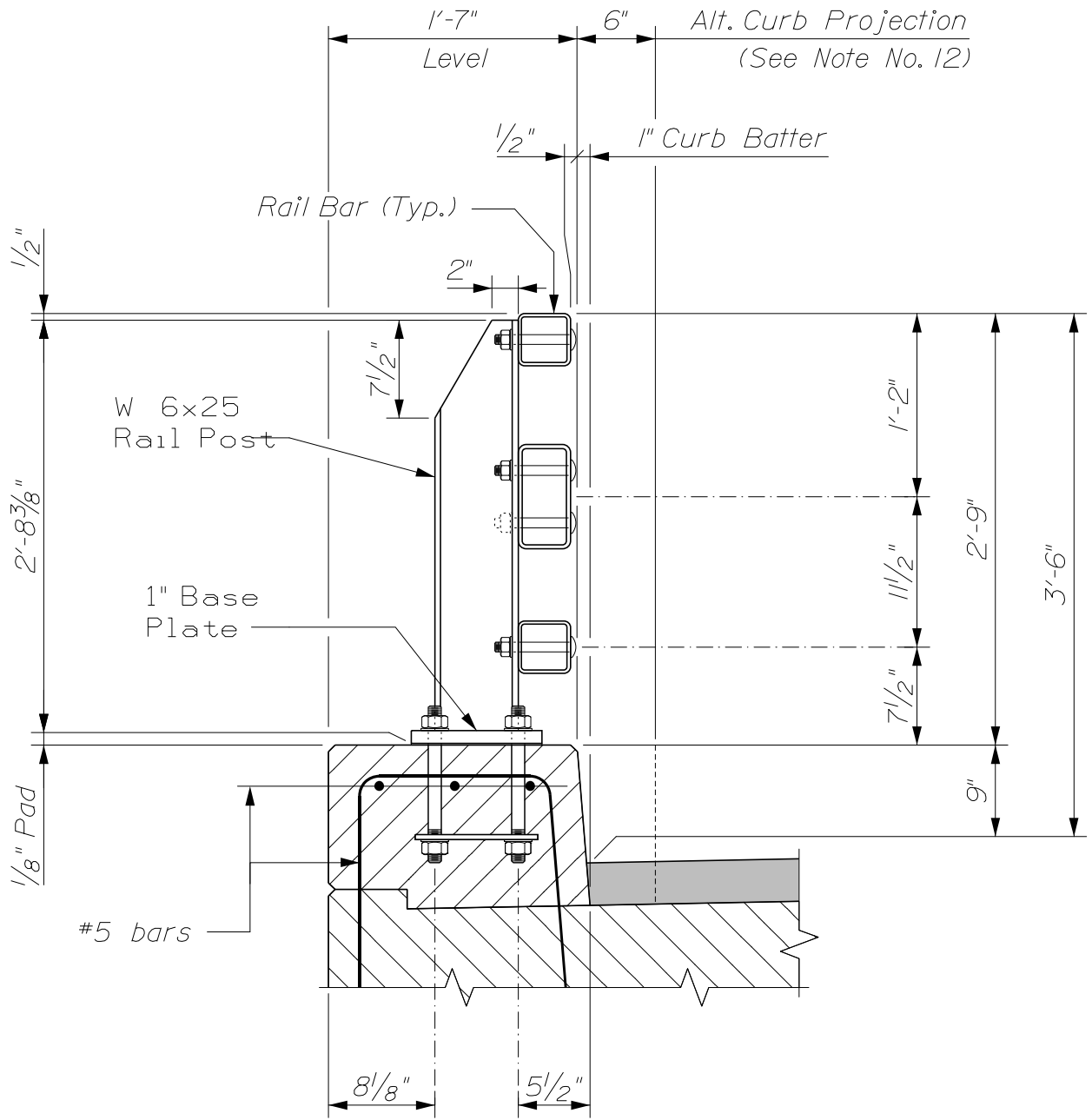

~ TYPICAL RAILING SECTION ~  
 (3 - Bar Traffic / Bicycle Railing)

STEEL BRIDGE RAILING  
 507(05)

Rail Bars:  
 HSS 8x4x $\frac{5}{16}$  (1)  
 HSS 4x4x $\frac{1}{4}$  (3)

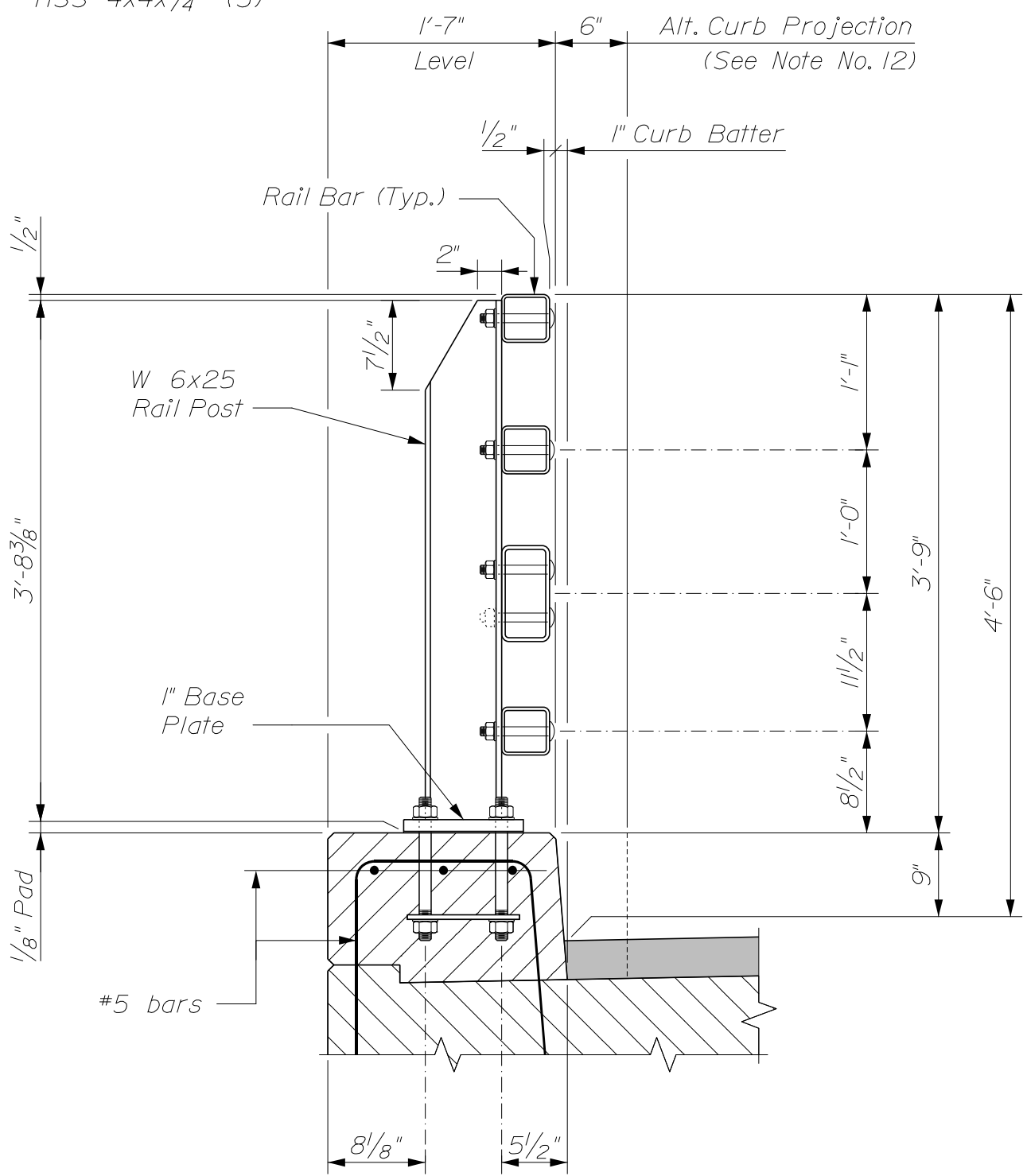

~ TYPICAL RAILING SECTION ~  
 (4 - Bar Traffic / Bicycle Railing)

STEEL BRIDGE RAILING  
 507(06)

Rail Bars:  
 HSS 8x4x $\frac{5}{16}$  (1)  
 HSS 4x4x $\frac{1}{4}$  (3)

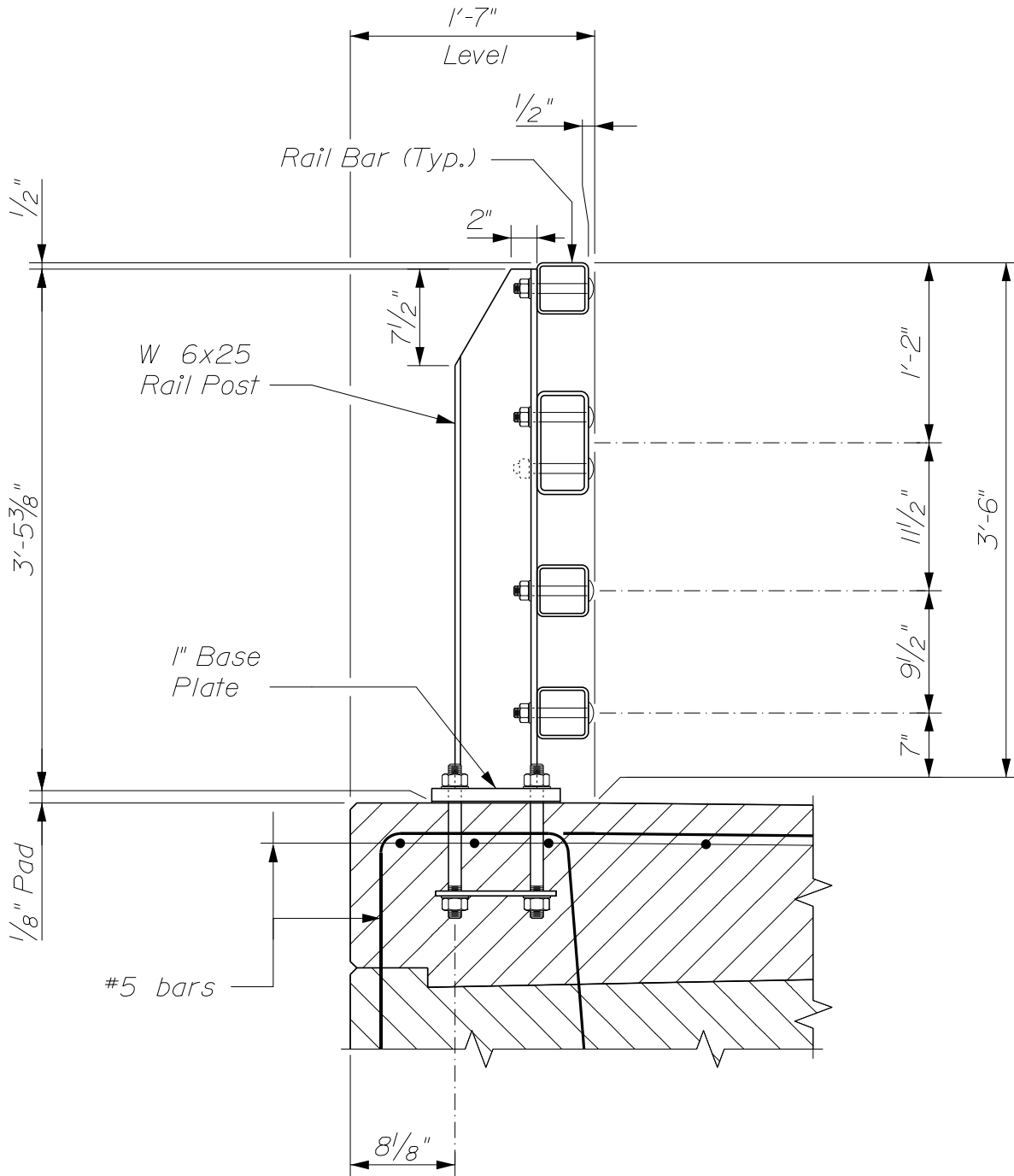

~ TYPICAL RAILING SECTION ~  
 (4 - Bar Traffic / Pedestrian Railing)

STEEL BRIDGE RAILING  
 507(07)

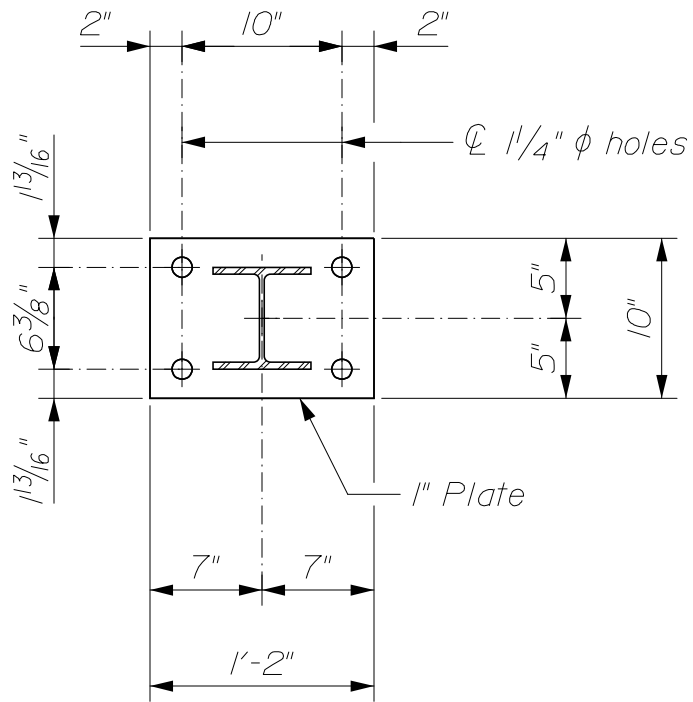

~ POST & BASE PLATE PLAN ~

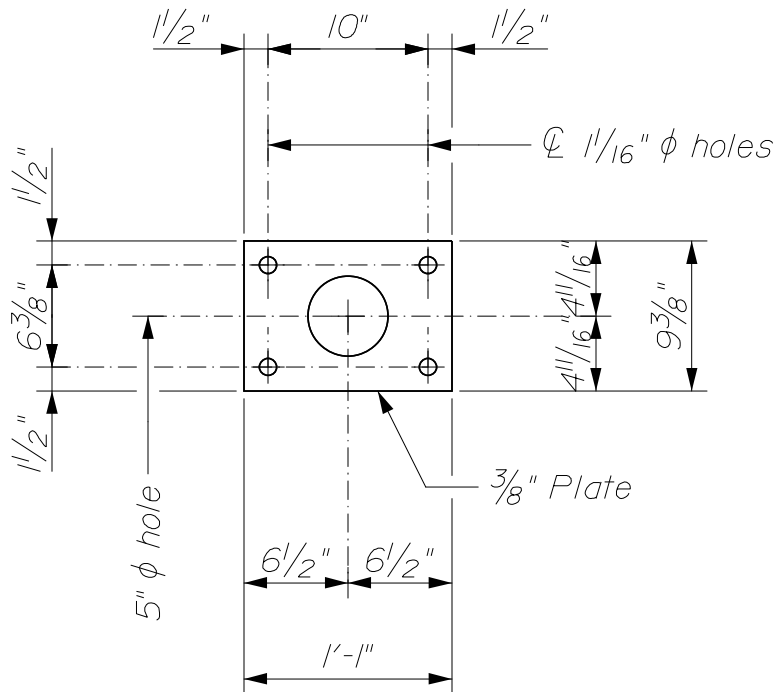

~ ANCHOR PLATE PLAN ~

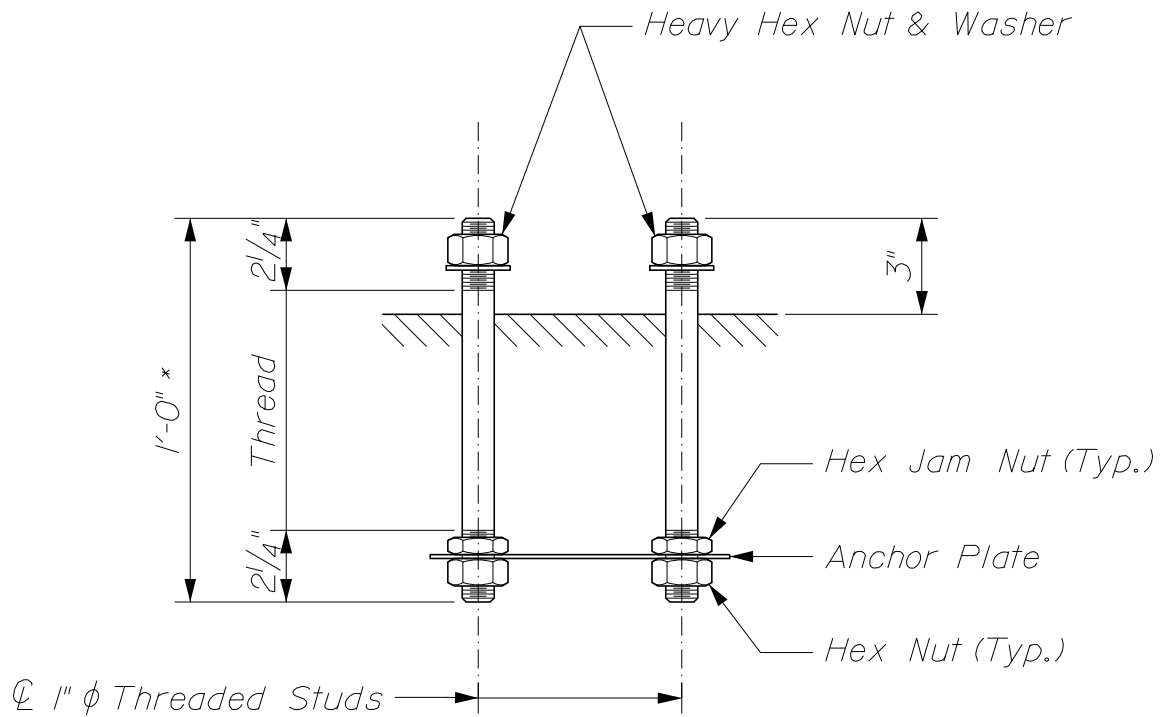

~ RAIL POST ANCHORAGE ~

\* = 9" for curb with integral concrete wearing surface.

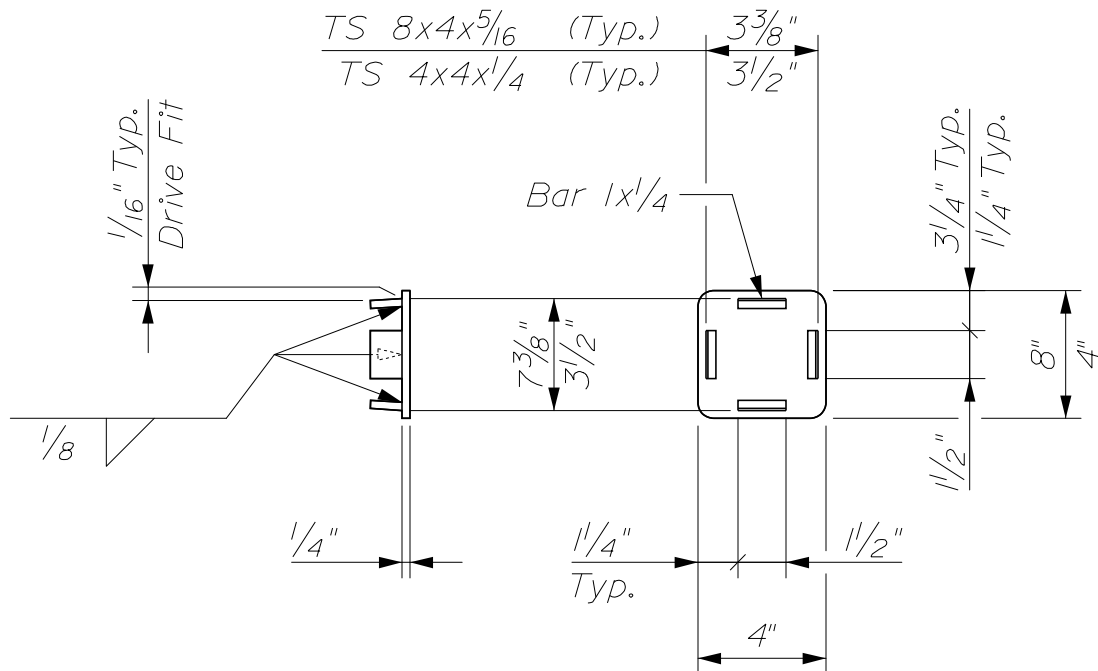

~ RAIL BAR CAP ~

Note: Match corner radius of rail bar

Seal Weld  
flange edges

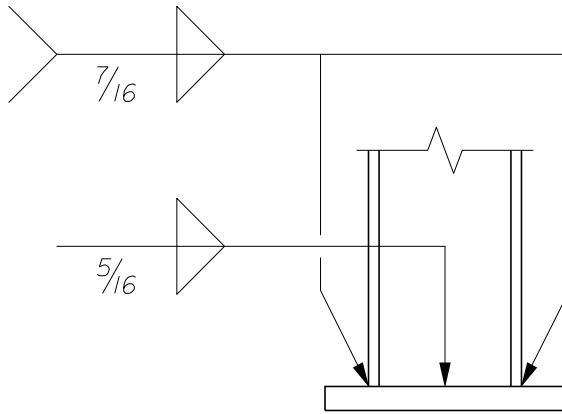

~ POST - TO - BASE WELD DETAIL ~

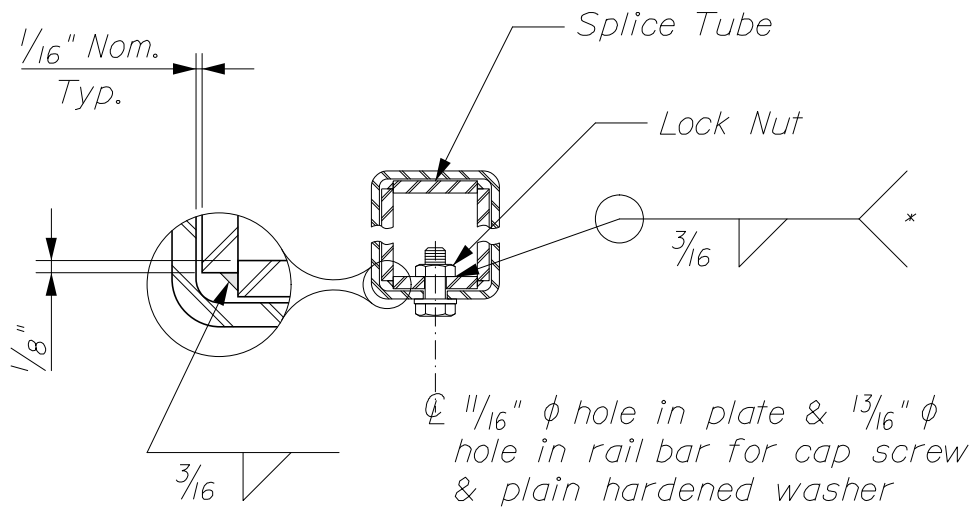

~ RAIL BAR SPLICE SECTION ~

\* Weld nuts to plate before assembling splice tube

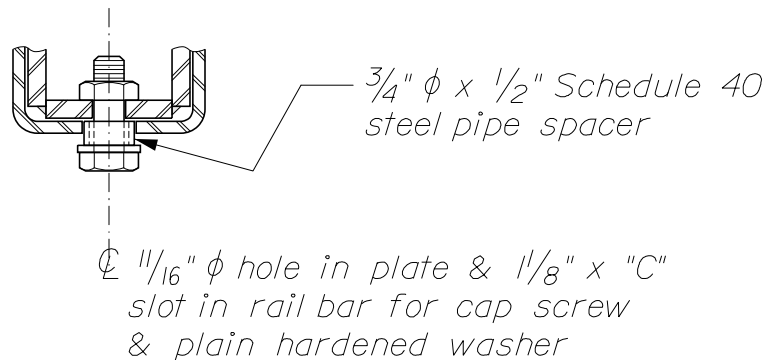

~ RAIL BAR EXPANSION JOINT SECTION ~  
For details not shown, see "Rail Bar Splice Section"

# STEEL BRIDGE RAILING

507(10)

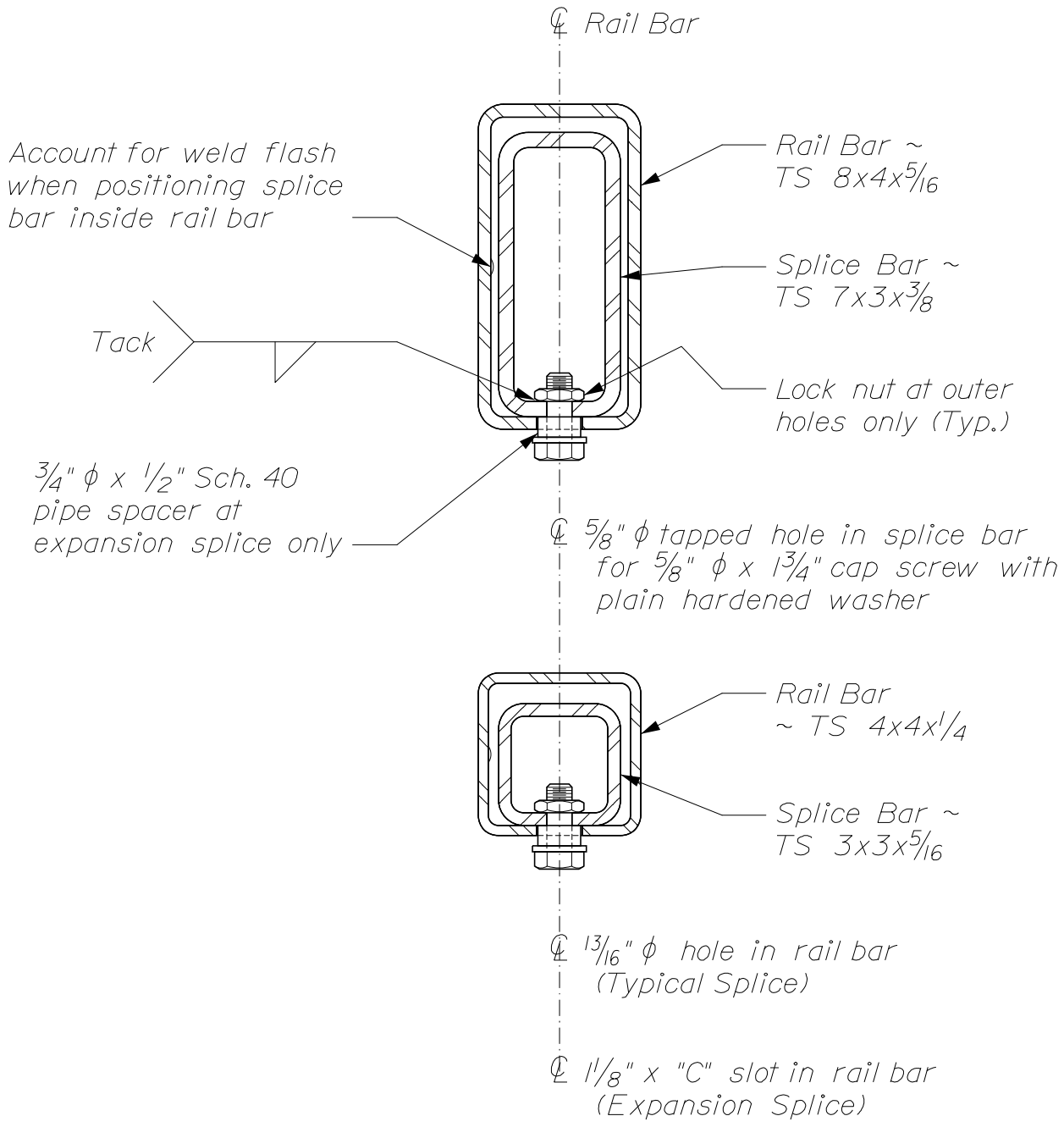

-- OPTIONAL RAIL BAR SPLICE SECTION --  
 (Details Typical for both rail bars)

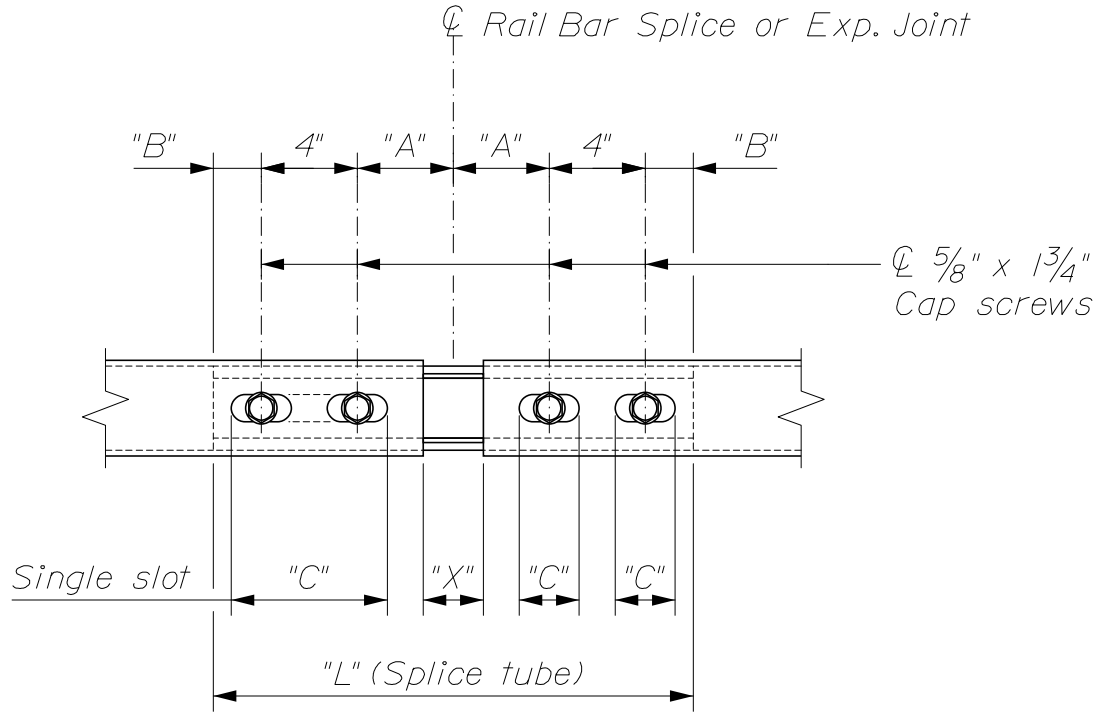

~ RAIL BAR SPLICE & EXPANSION JOINT DETAIL ~  
(Bottom View)

SPLICE TUBE DIMENSIONS		
	TS 8x4	TS 4x4
Top & Bot. Plates	2 1/2 x 3/8 x "L"	2 5/8 x 3/8 x "L"
Side Plates	6 3/4 x 3/8 x "L"	2 7/8 x 3/8 x "L"

SPLICE & EXPANSION JOINT TABLE					
"T"	"A"	"B"	"C"	"L"	"X"
Splice	4"	2"	--	1'-8"	3/4"
≤ 4"	4"	2"	2 1/2"	1'-8"	2 1/2"
> 4" ≤ 6 1/2"	5 1/2"	2 1/2"	3 1/2"	2'-0"	3 3/4"
> 6 1/2" ≤ 9"	6 1/2"	3 1/2"	9" *	2'-4"	5"
> 9" ≤ 13"	8 1/2"	4 1/2"	11" *	2'-10"	7"

T = Total Movement

\* = Single Slot

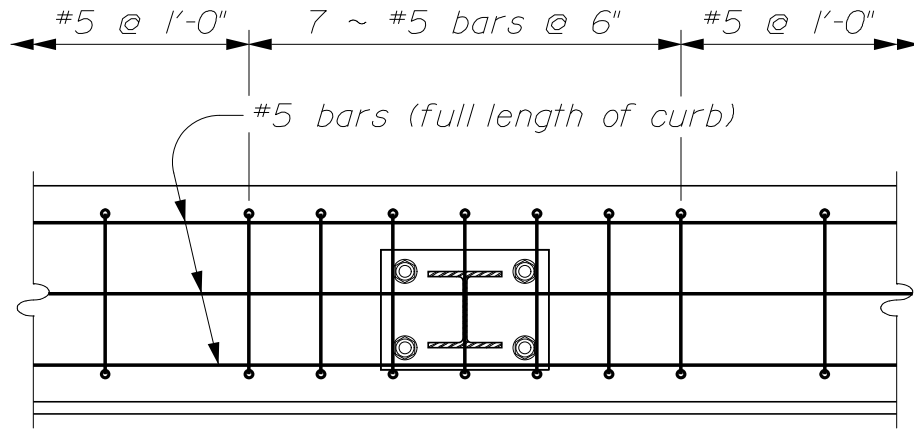

~ CURB REINFORCING PLAN ~

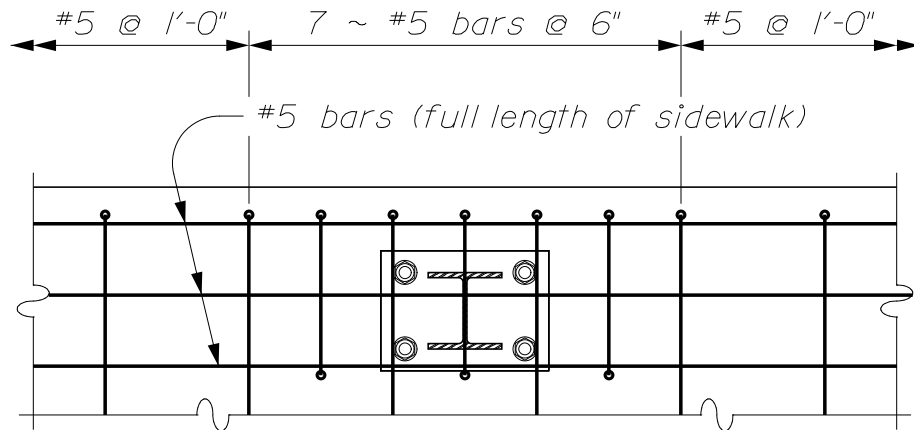

~ SIDEWALK REINFORCING PLAN ~

NOTES:

1. All work and materials shall conform to the provisions of Section 507 - Railings of the Standard Specifications.

2. Tubing shall meet the longitudinal CVN minimum requirements of 15 ft-lb at 0° F or proportional values of sub - size specimens. Testing shall be done in accordance with ASTM A673. The H frequency shall be used and the material shall be as - rolled.

3. All exposed cut or sheared edges shall be broken and free of burrs. The inside weld flash of tubing shall be removed at splices and expansion joints.

4. Rail posts shall be set normal to grade unless otherwise shown.

5. Lengths of rail bar shall be attached to a minimum of 2 rail posts and to at least 4 posts whenever possible.

6. Rail bar expansion joints shall be provided in any rail bay spanning a superstructure expansion joint. Expansion joint width shall be "X" at 45° F and will be adjusted in the field as directed by the Resident. Refer to detail and table on page 507(12) for dimension "X".

7. All parts shall be galvanized after fabrication in accordance with except that hardware shall meet the requirements of either ASTM F2329 or ASTM B695, Class 50, Type I. Parts except hardware shall be blast - cleaned prior to galvanizing in accordance with SSPC - SP6.

8. Anchor bolts shall be set with a template. Nuts securing the post base plate shall be tightened to a snug fit and given an additional  $\frac{1}{8}$  turn.

9. Bolts for attaching rail bars to posts shall be  $\frac{3}{4}$ " Diameter round or dome head and may be rib neck, slotted, wrench head or tension control (TC or twist - off). Holes in posts shall be  $\frac{1}{16}$  inch larger than the diameter of the bolt. Holes in rail bars shall be drilled to size as follows:

Slotted, wrench head or TC bolts:  $\frac{1}{16}$ " larger than bolt diameter

Rib neck bolts: Size appropriate to accommodate an interference fit

Bolts shall be 6 inches in length and shall include a flat washer under the nut.

(Continued)

NOTES (Continued):

10. Holes in rail bars shall be field - drilled and shall be coated with an approved zinc - rich paint prior to erection.

11. Bolts in expansion joints shall be tightened only to a point that will allow rail movement.

12. The alternate curb projection shown for the curb - mounted railings is intended for use with granite bridge curb.

13. If there is a conflict between these Standard Details and the Design Drawings, the Contractor shall notify the Resident immediately.

MATERIALS:

Rail bars & rail splice bars ..... ASTM A500, Grade C  
Rail posts, base plates  
& fabricated splice bars ..... AASHTO M 270M/M 270, Grade 50  
All other shapes & plates ..... ASTM A36/A36M  
Anchor bolts, washers & heavy hex nuts ..... AASHTO M 314, Grade 105  
Rail attachment bolts ..... ASTM A449  
All other bolts & nuts (unless noted) ..... ASTM A307 & ASTM A563,  
Grade D or DH

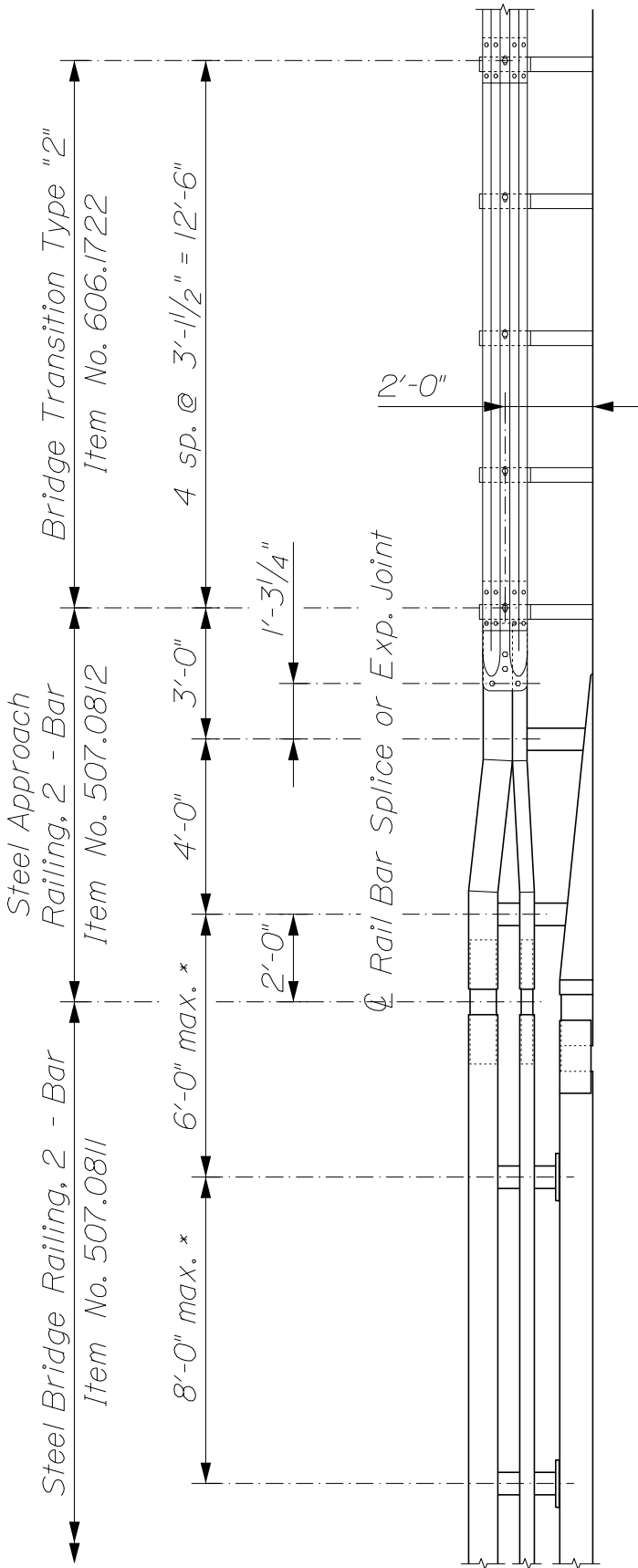

~ ELEVATION ~  
 \* See Design Drawings for dimensions

**NOTES:**

1. The bottom rail bar may be bent to shape from one continuous length of stock provided that the fabricator can achieve the required geometry without deforming the tube.
2. To facilitate field fit-up of the approach railing, posts shall be set loosely into fiber form tubes while parts are being assembled. Post holes shall be backfilled with Class "S" or other concrete mix approved by the Resident. Payment will be considered incidental to the Steel Approach Railing pay item.

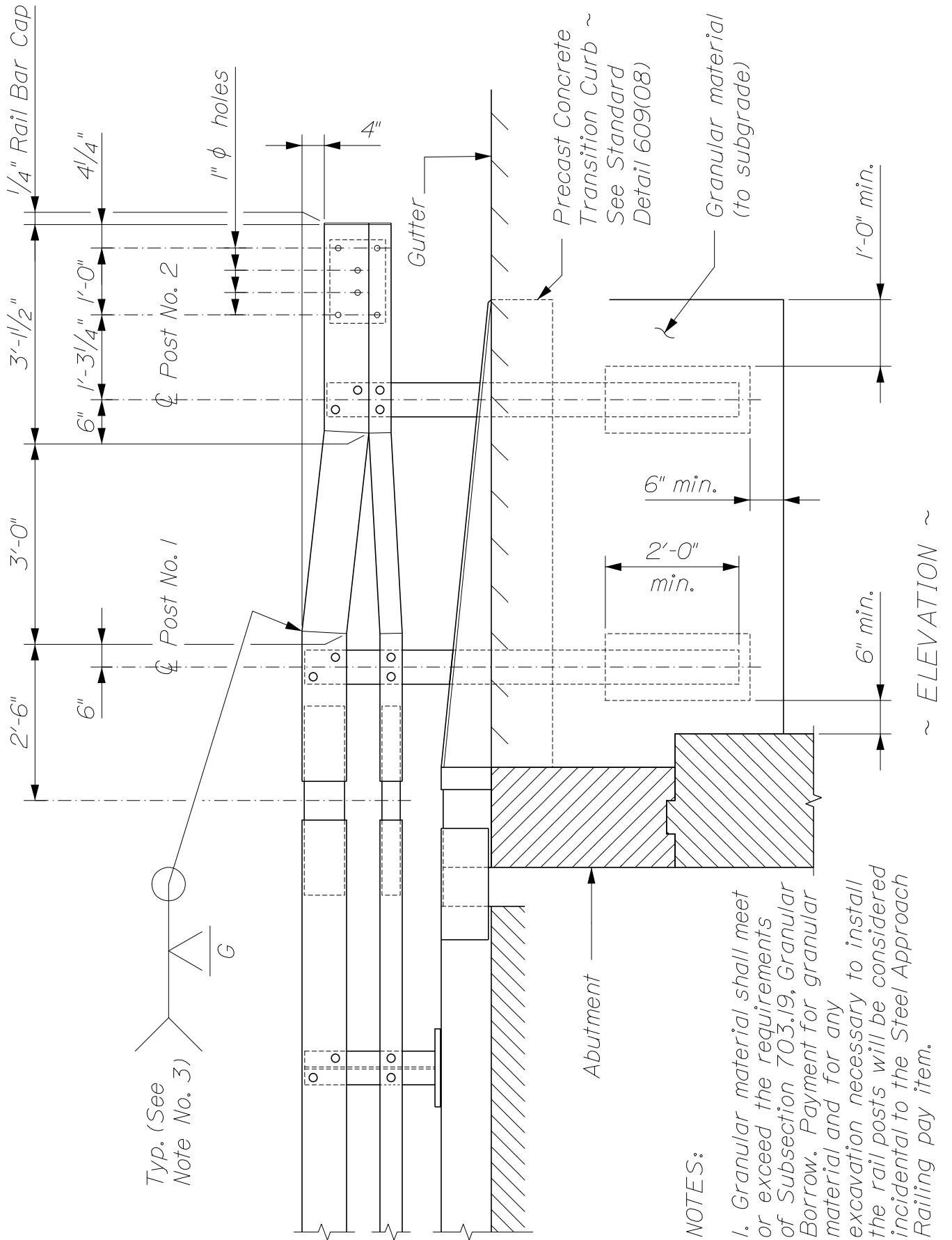

STEEL APPROACH RAILING, 2-BAR  
507(17)

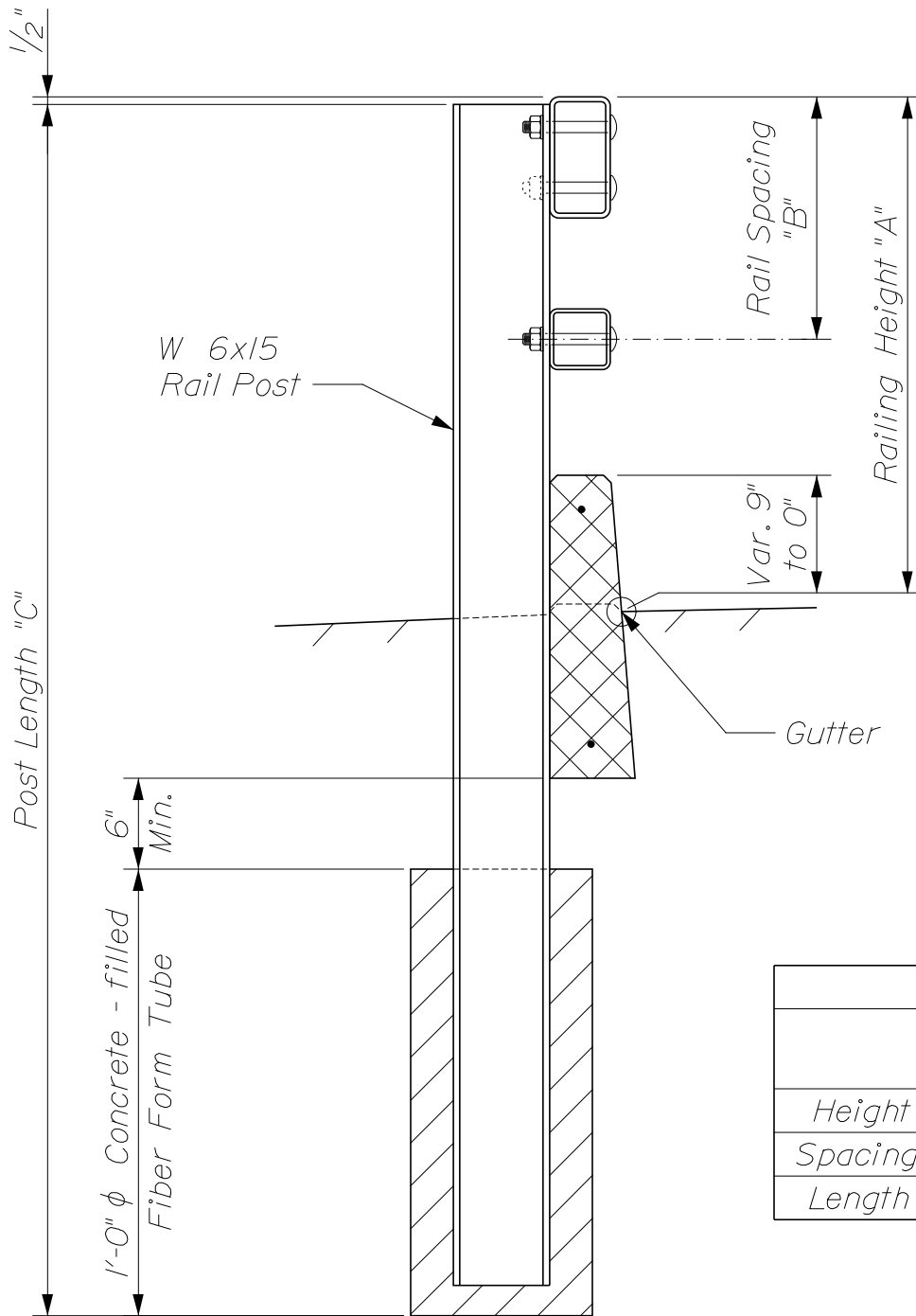

DIMENSIONS		
	Post No. 1	Post No. 2
Height "A"	2'-10"	2'-6"
Spacing "B"	1'-4"	10"
Length "C"	6'-6"	6'-2"

~ TYPICAL SECTION ~

STEEL APPROACH RAILING, 2-BAR  
507(18)

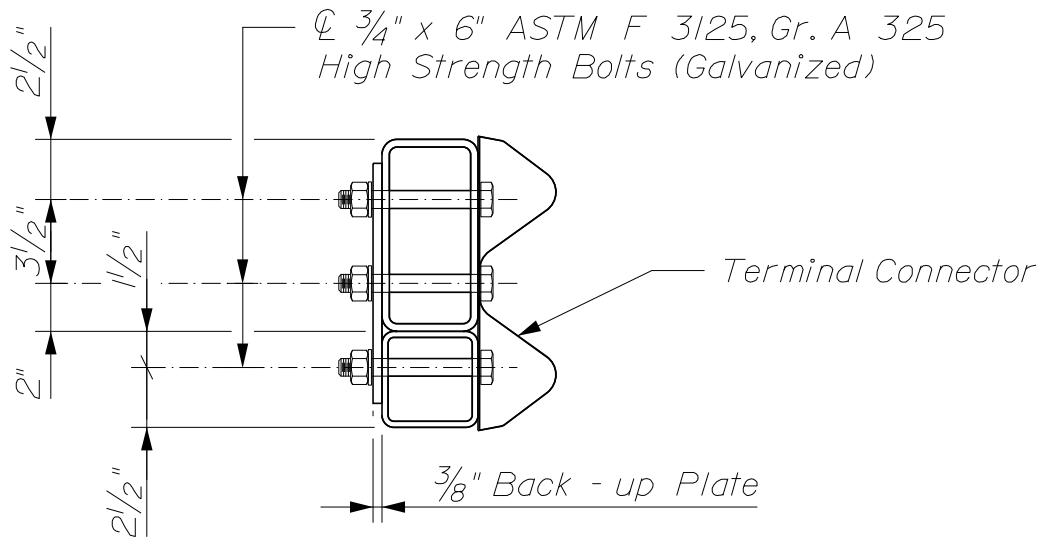

~ SECTION THROUGH  
 TERMINAL CONNECTOR ~

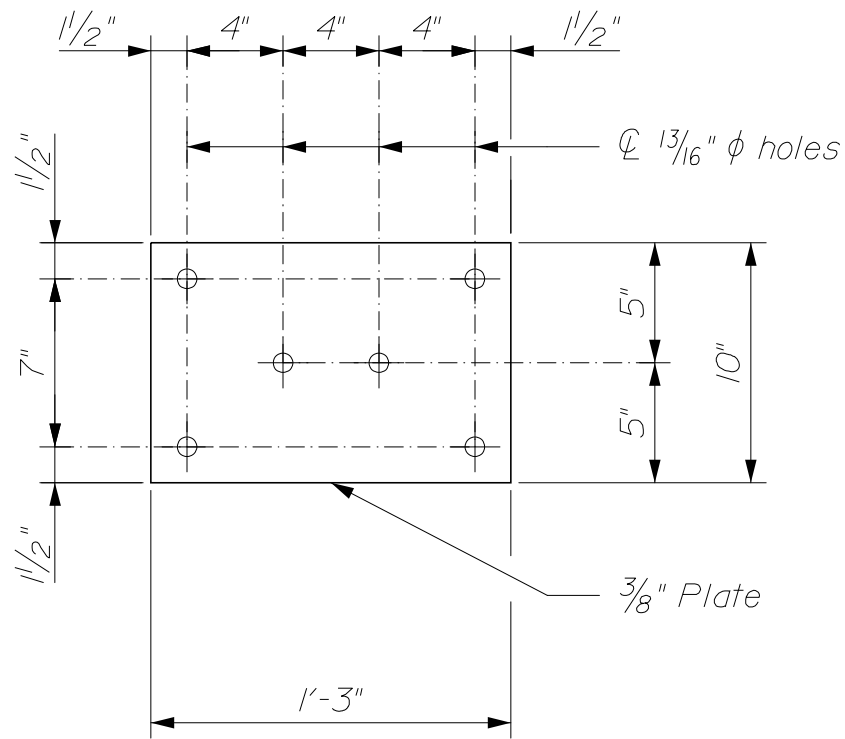

~ BACK - UP PLATE ~

NOTES:

1. The Bridge Transition Type "2" as shown is a slight modification of the standard Type "2" detail shown in Section 606. The  $\frac{3}{4}$ "  $\phi$  bolts and back - up plate will be considered as part of the Steel Approach Railing pay item.

STEEL APPROACH RAILING, 2-BAR

507(19)

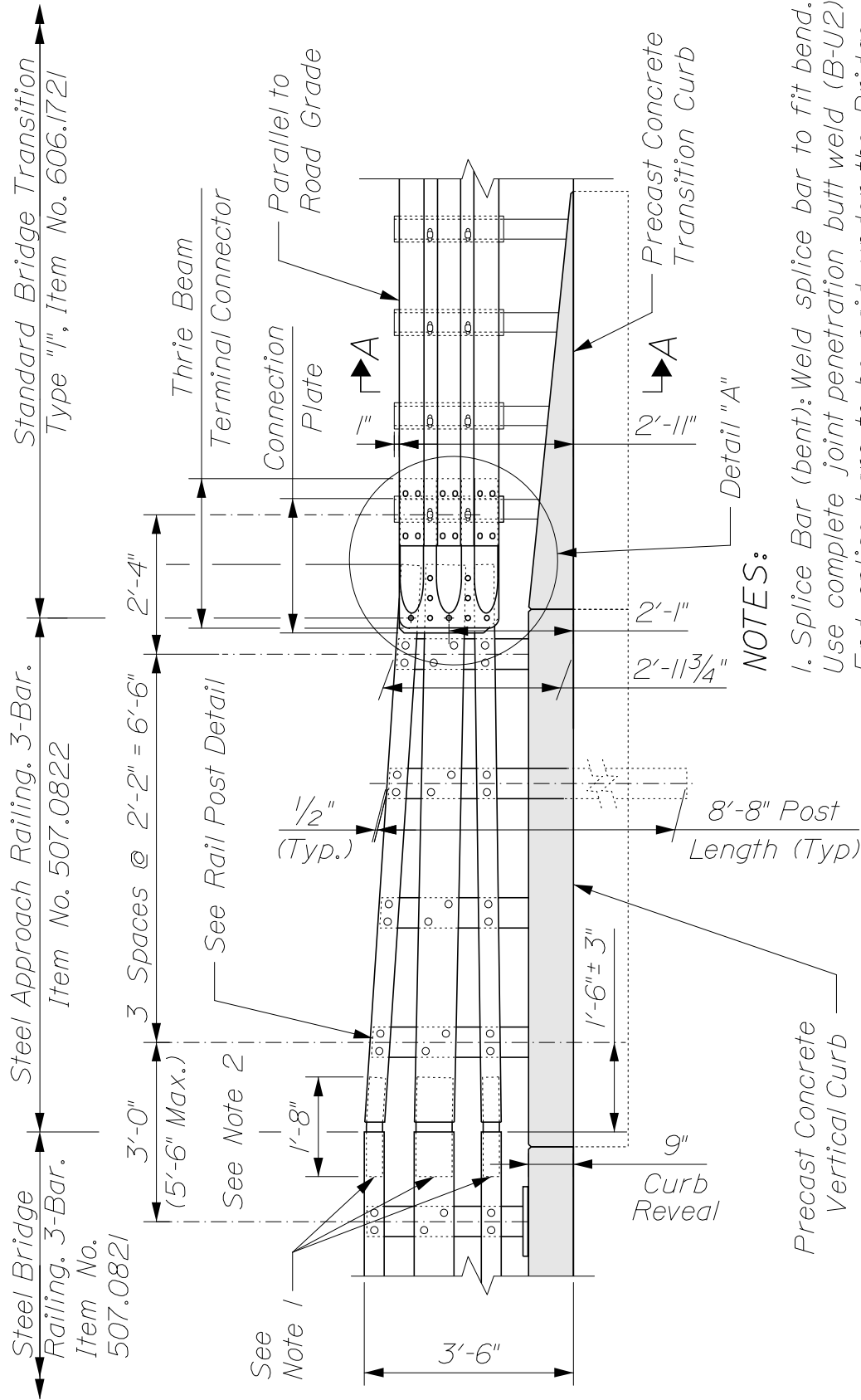

**NOTES:**

1. Splice Bar (bent): Weld splice bar to fit bend. Use complete joint penetration butt weld (B-U2). End splice bars to be paid under the Bridge Railing item.

2. Three foot spacing to first post on bridge is standard. For longer expansion joints, the first post on the bridge may be located up to 5'-6" from the previous post in the approach.

~ ELEVATION ~

STEEL APPROACH RAILING, 3-BAR  
507(20)

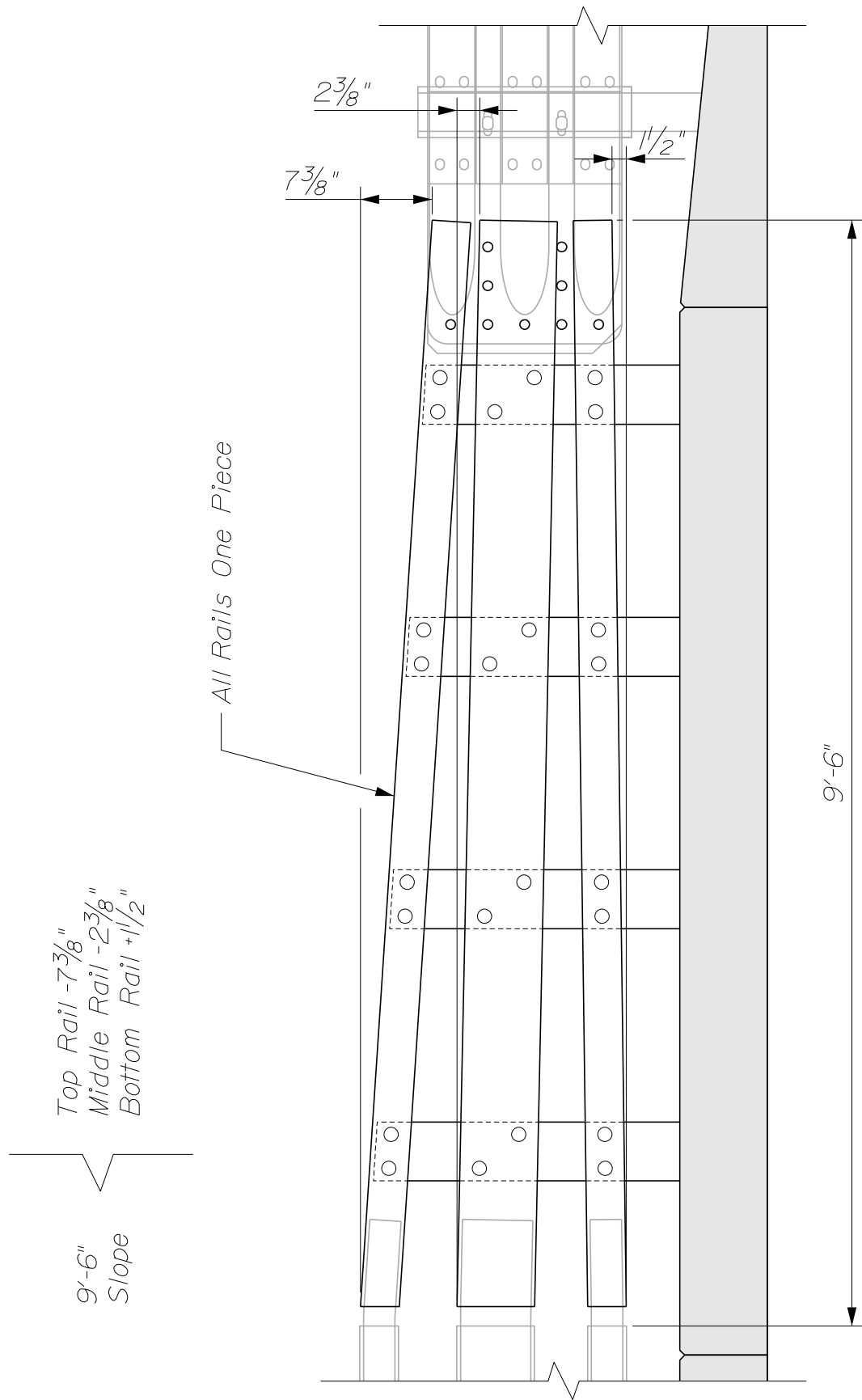

~ DETAIL - RAIL SLOPE ~

STEEL APPROACH RAILING, 3-BAR  
 507(21)

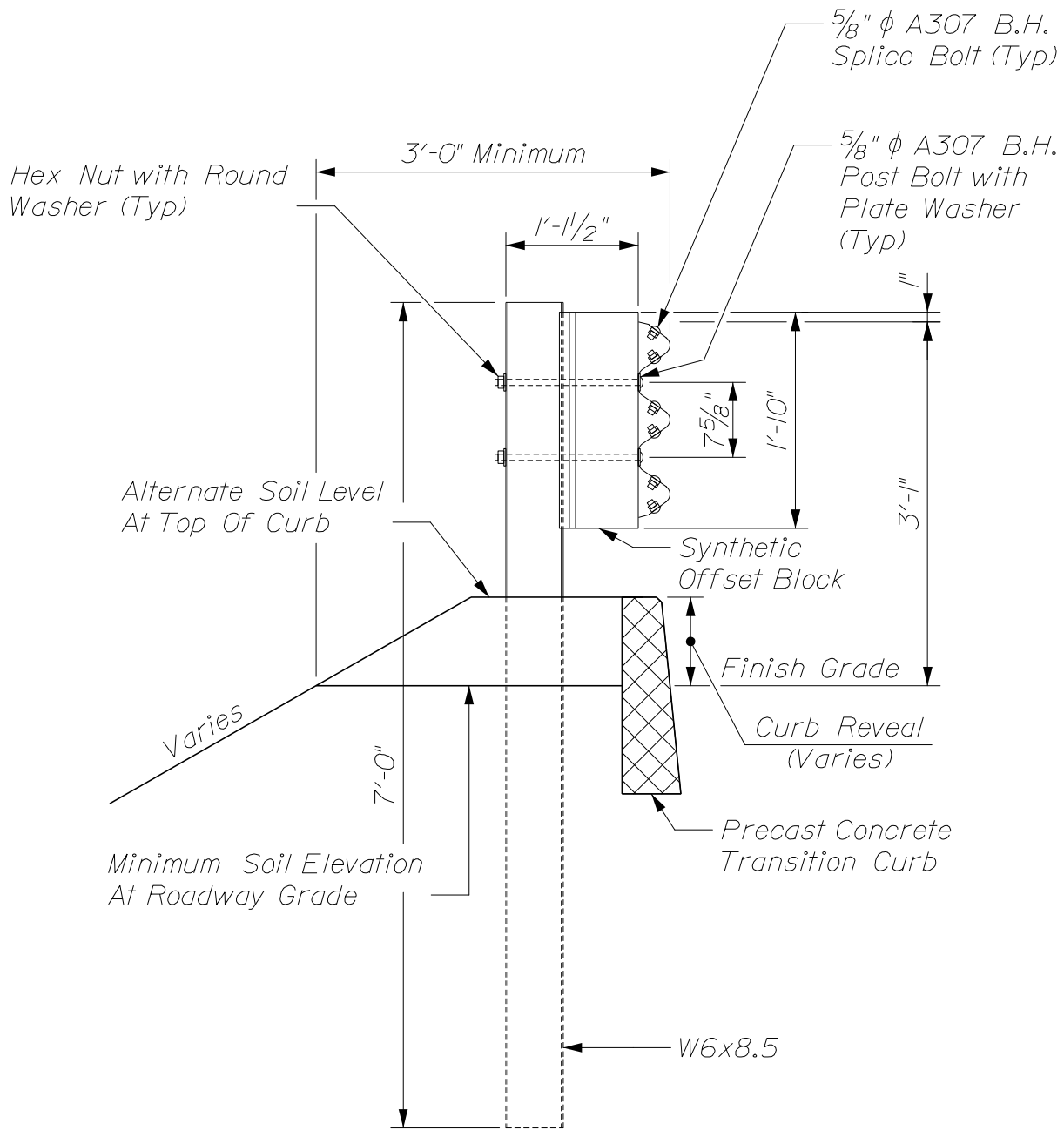

~ SECTION A-A ~  
(POST RAIL ASSEMBLY)

STEEL APPROACH RAILING, 3-BAR  
507(22)

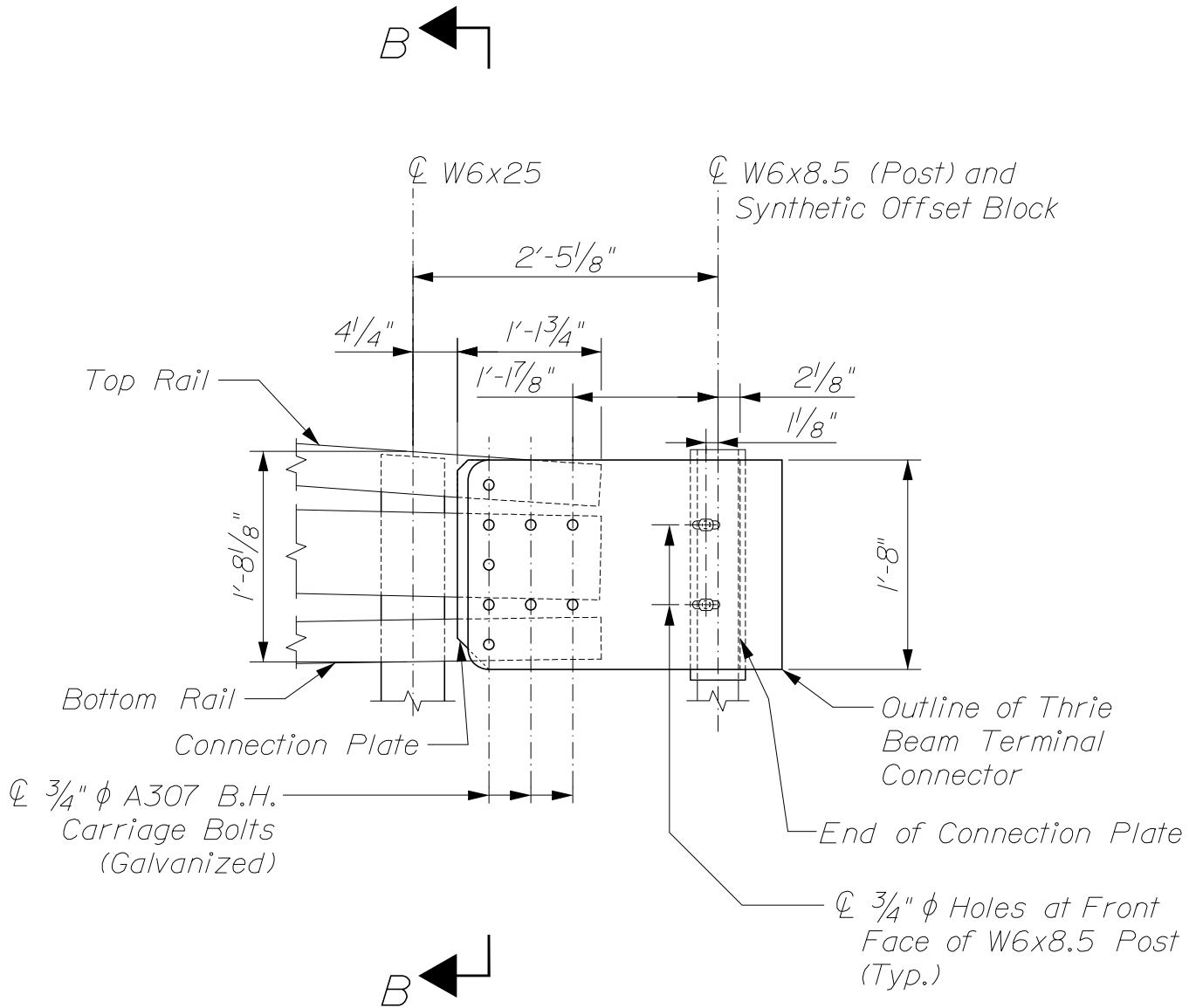

~ DETAIL "A" ~  
 (Overlapping of Double Nested Thrie-Beam not Shown for Clarity)

STEEL APPROACH RAILING, 3-BAR  
 507(23)

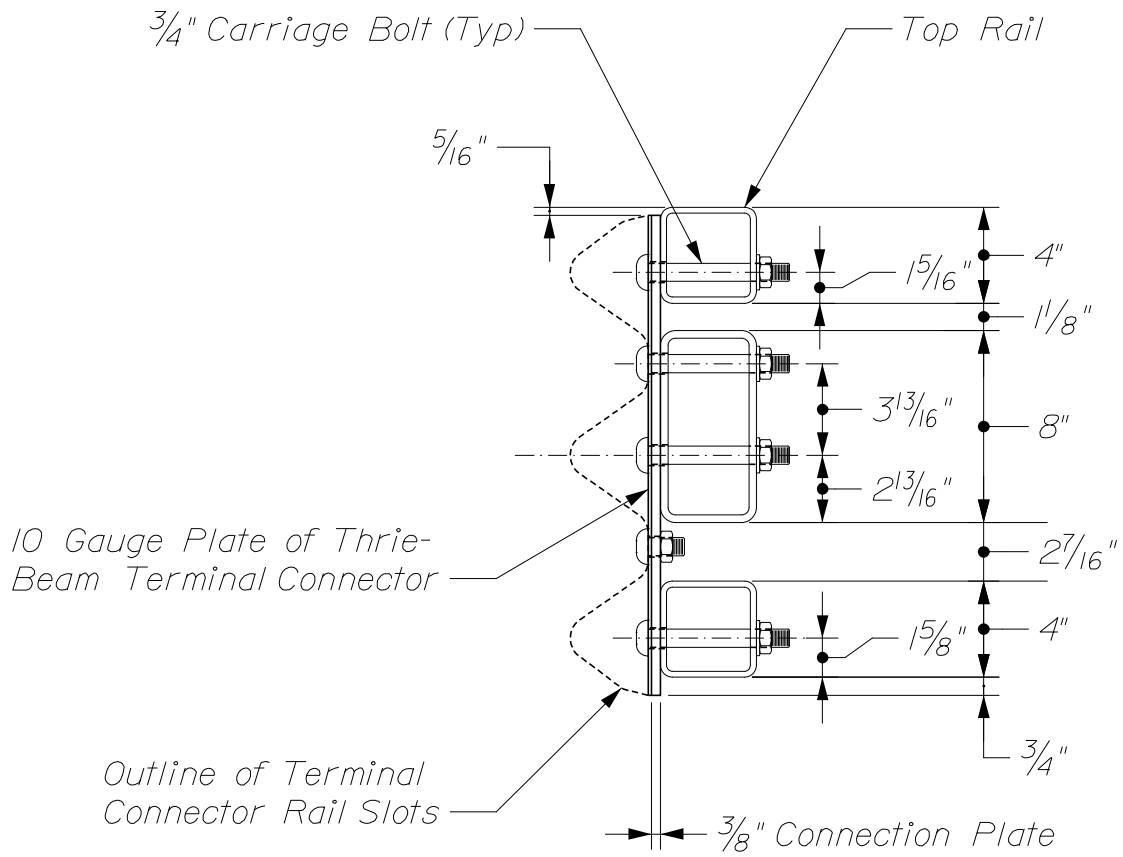

~ SECTION B-B (CONNECTION PLATE) ~

STEEL APPROACH RAILING, 3-BAR  
507(24)

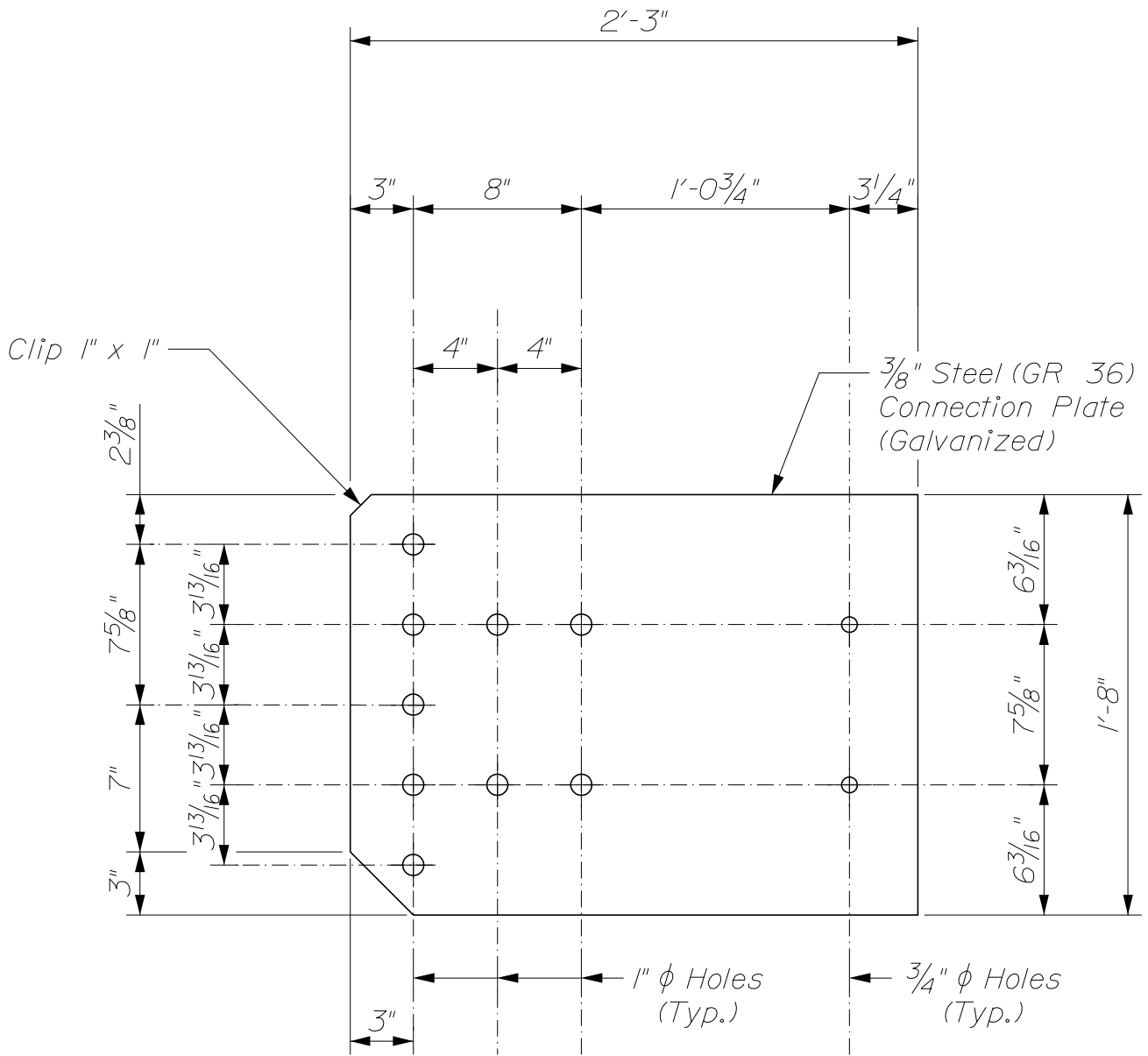

~ DETAIL - CONNECTION PLATE ~

STEEL APPROACH RAILING, 3-BAR  
507(25)

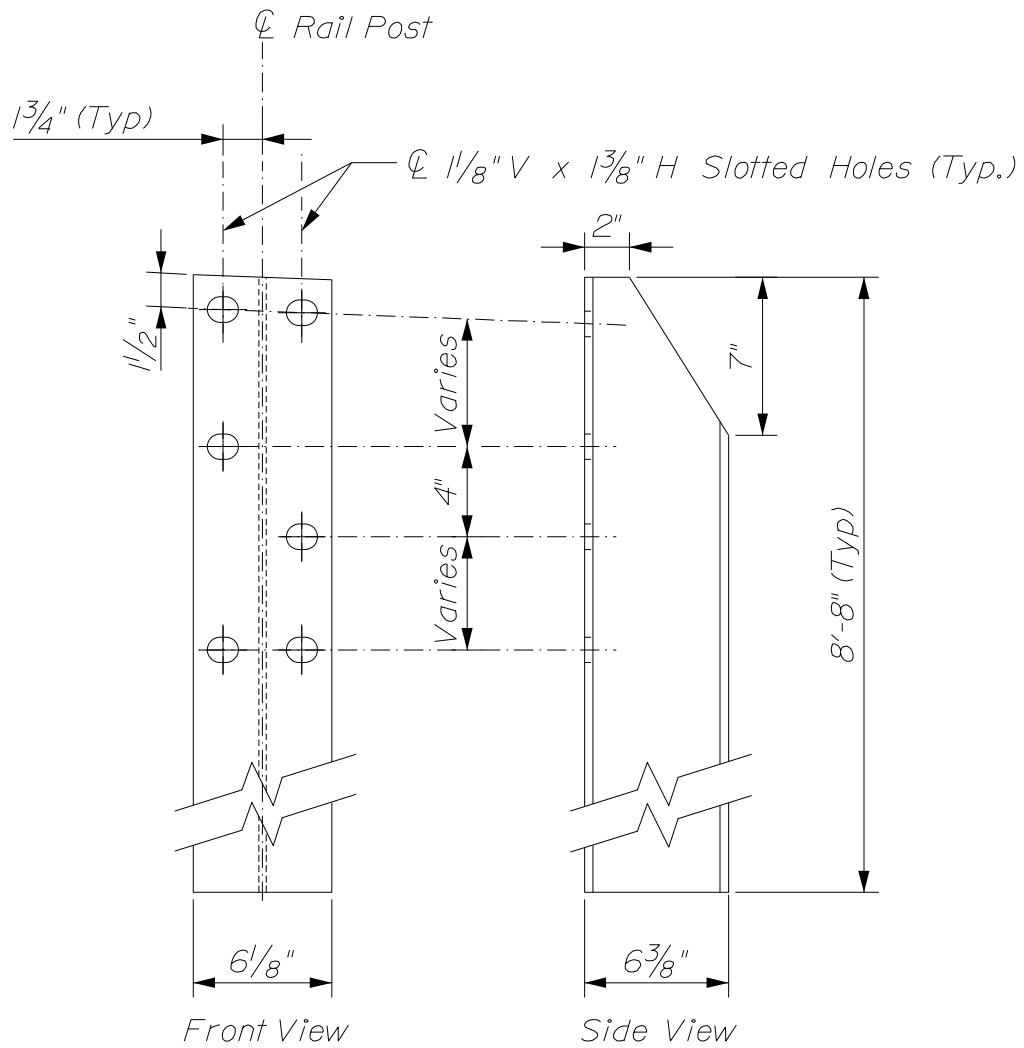

~ DETAIL - RAIL POST (W6x25) ~

STEEL APPROACH RAILING, 3-BAR  
507(26)

*NOTES:*

*1. Refer to Steel Bridge Railing pages for additional details, notes and materials specifications.*

*2. Rail bar welds shall have a minimum penetration of 80% as demonstrated by a test weld performed by the fabricator.*

*3. The precast concrete vertical or transition curb shall meet the provisions of Section 609 - Curbing of the Standard Specifications. The bridge end of the curb shall be saw - cut in the field to fit flush against the backwall, as dictated by the bridge skew angle and the profile grade. Where curbing is specified on the adjacent highway, the transition shall be modified accordingly.*

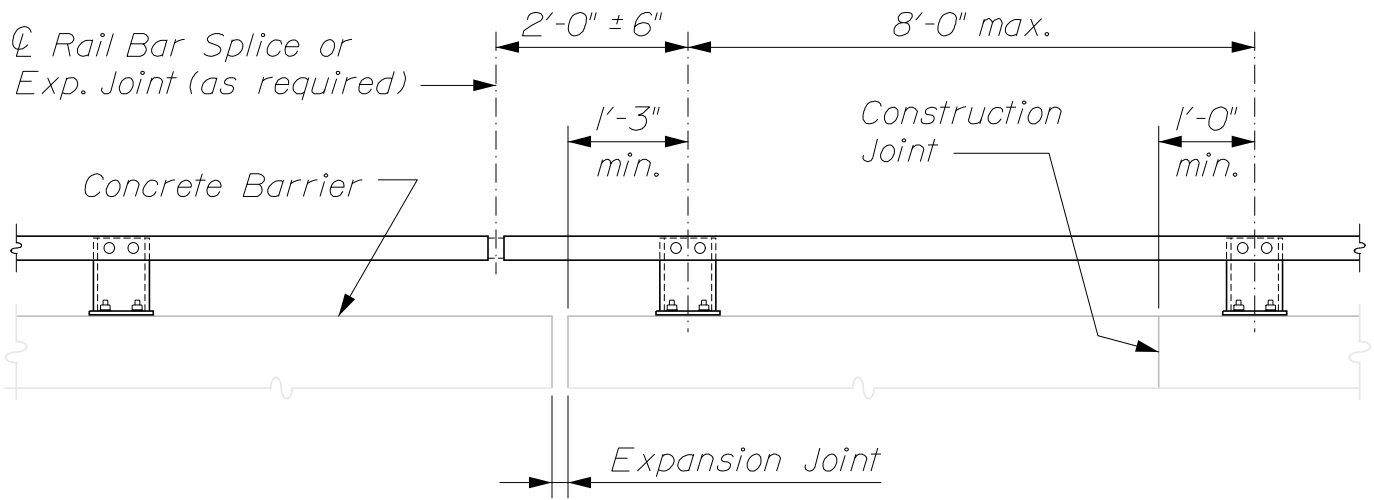

~ 1 - BAR PEDESTRIAN RAILING ~

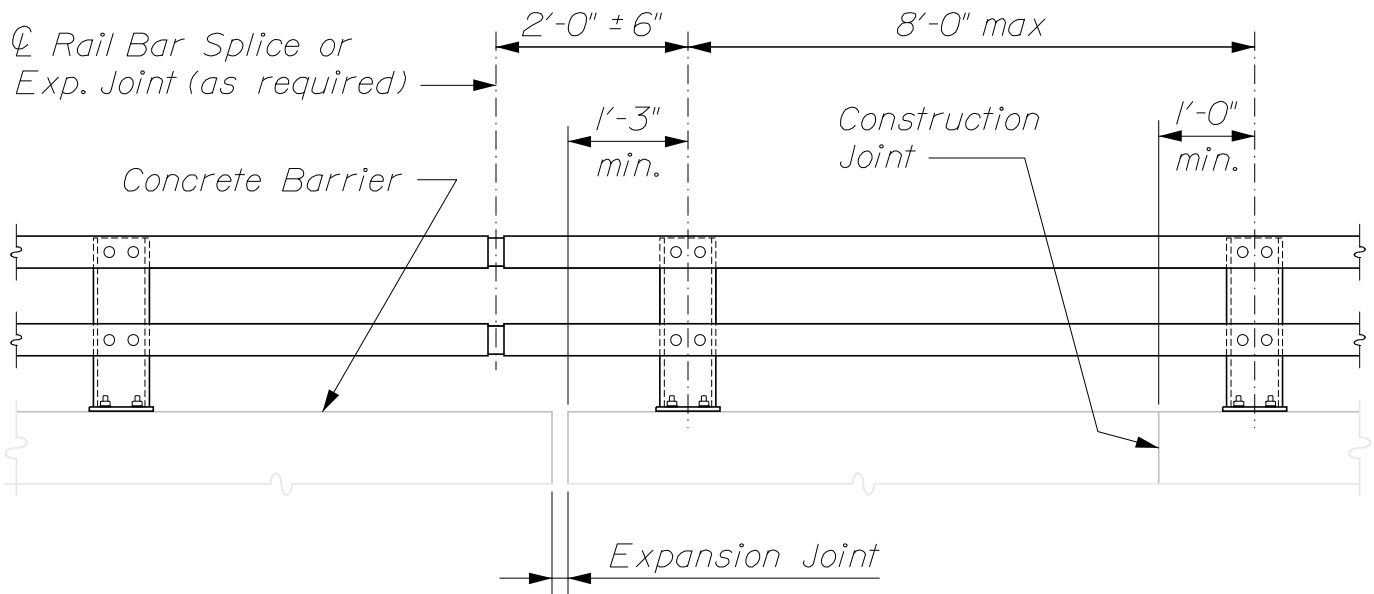

~ 2 - BAR BICYCLE RAILING ~

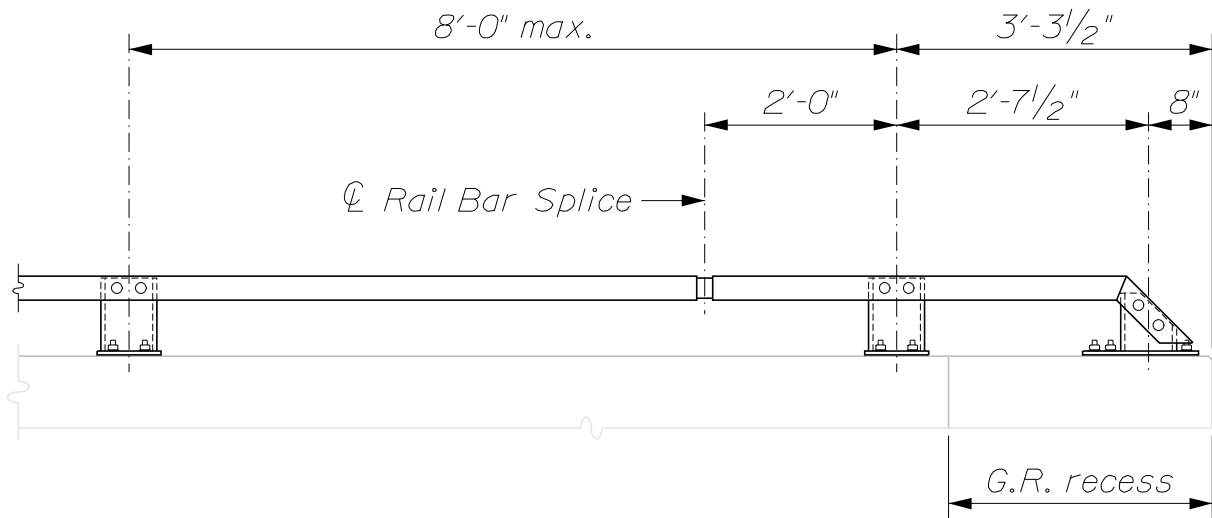

~ 1 - BAR PEDESTRIAN RAILING ~  
 (Showing End Treatment)

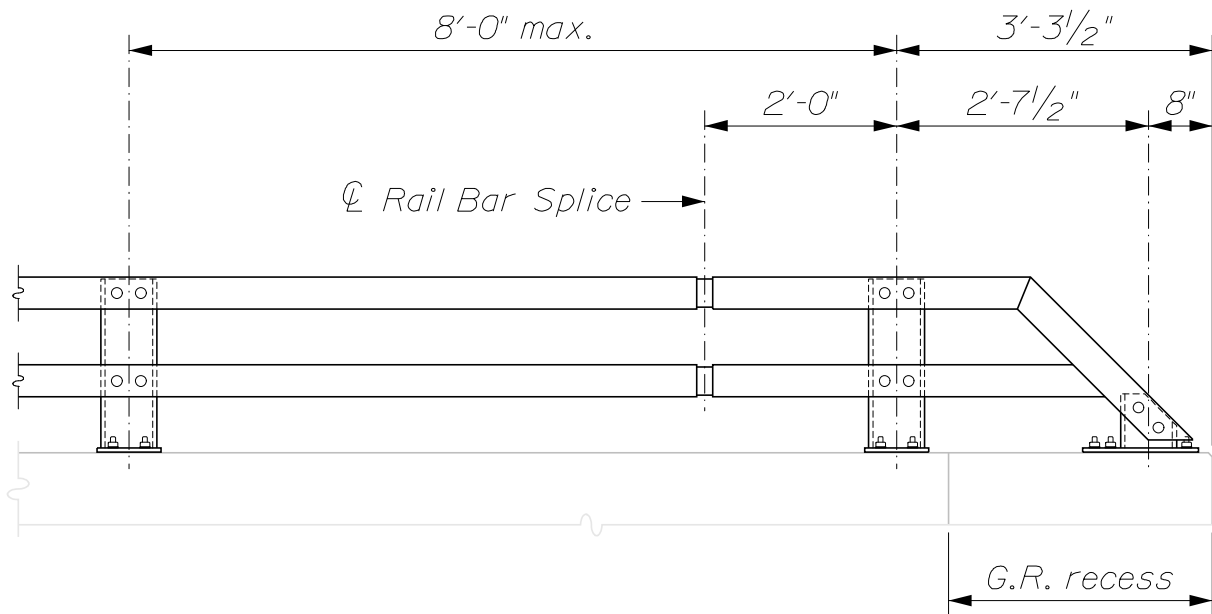

~ 2 - BAR BICYCLE RAILING ~  
 (Showing End Treatment)

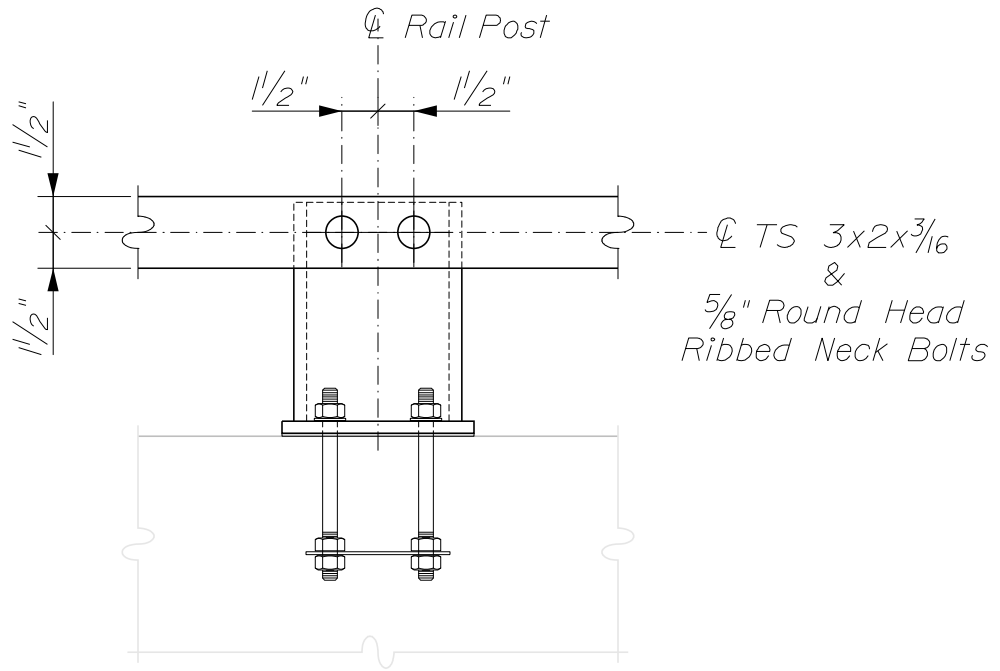

~ RAIL & POST ELEVATION ~  
 (1 - Bar Pedestrian Railing)

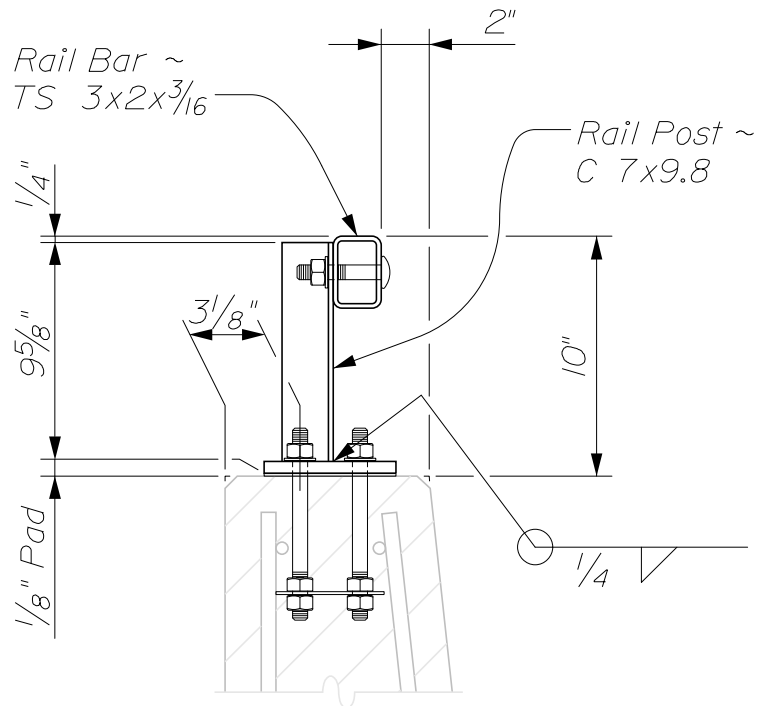

~ TYPICAL RAIL SECTION ~  
 (1 - Bar Pedestrian Railing)

BARRIER - MOUNTED STEEL BRIDGE RAILING  
 507(30)

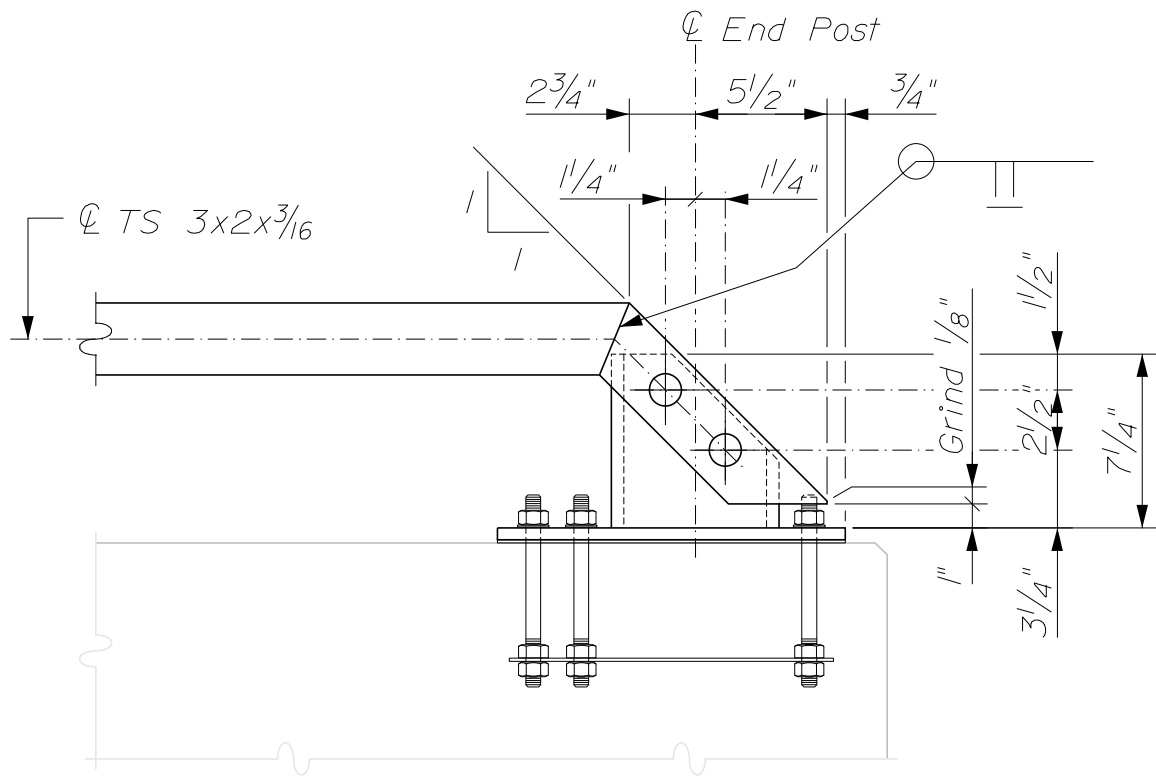

~ RAIL END TREATMENT ~  
 (1 - Bar Pedestrian Railing)

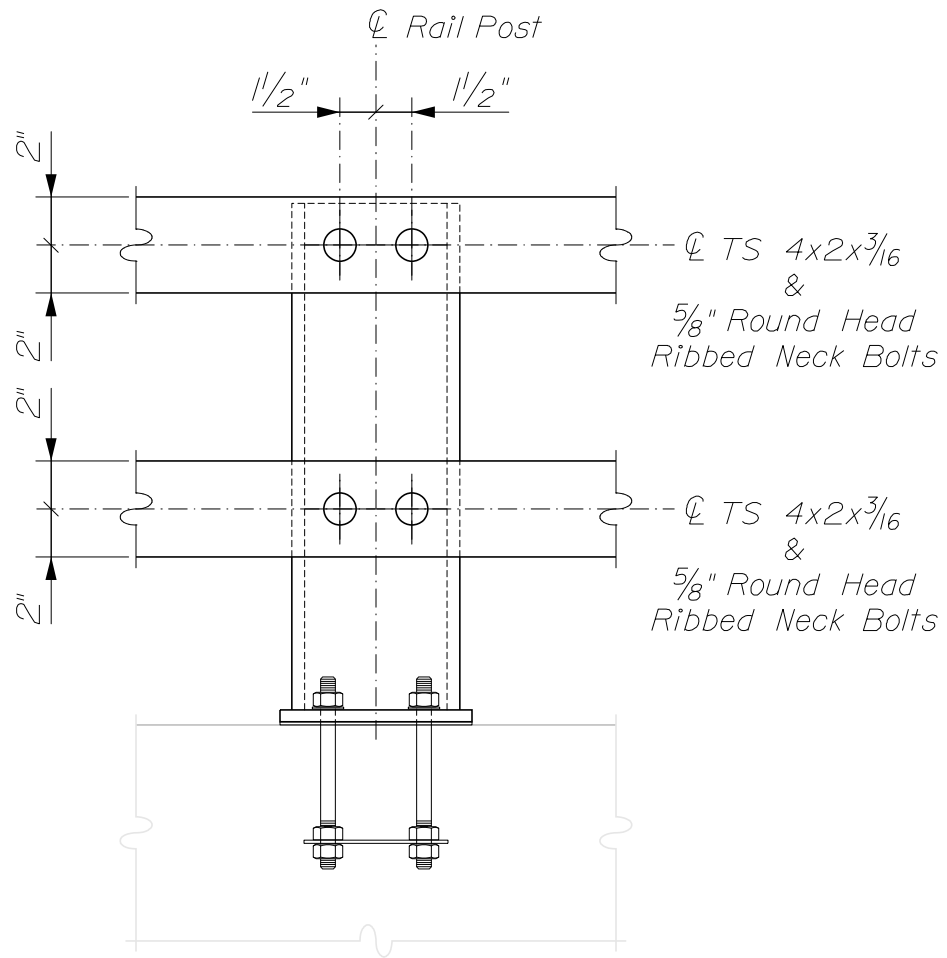

~ RAIL & POST ELEVATION ~  
 (2 - Bar Bicycle Railing)

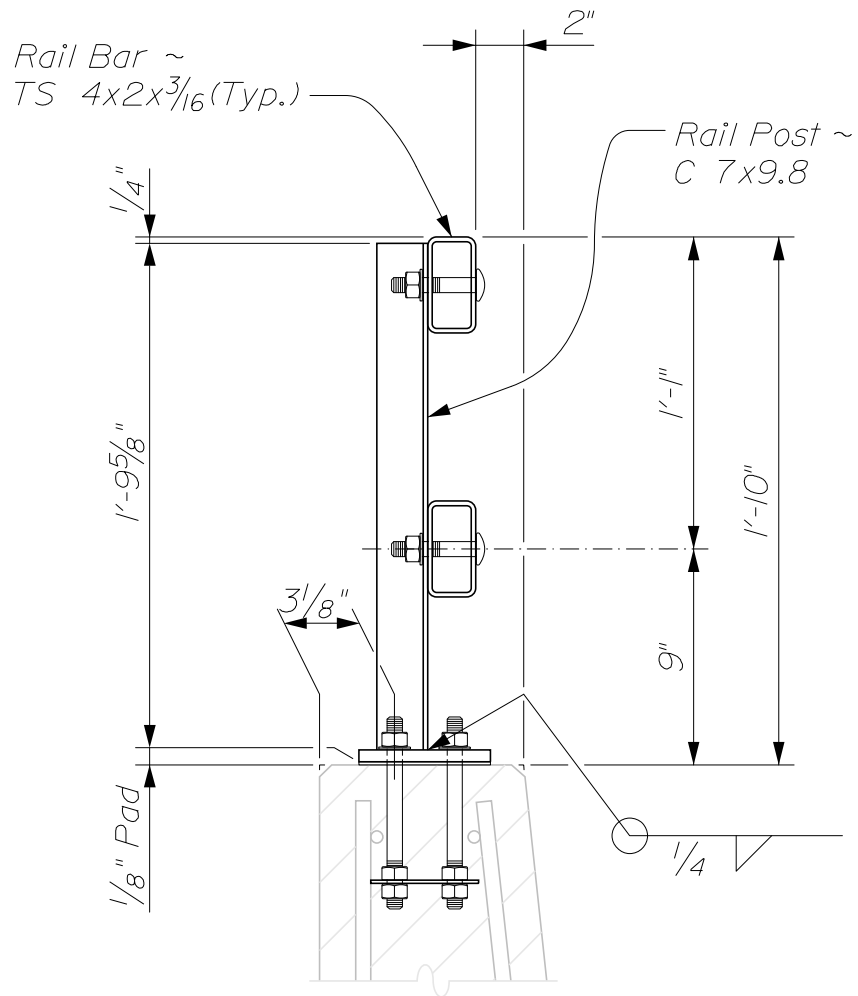

~ TYPICAL RAIL SECTION ~  
(2 - Bar Bicycle Railing)

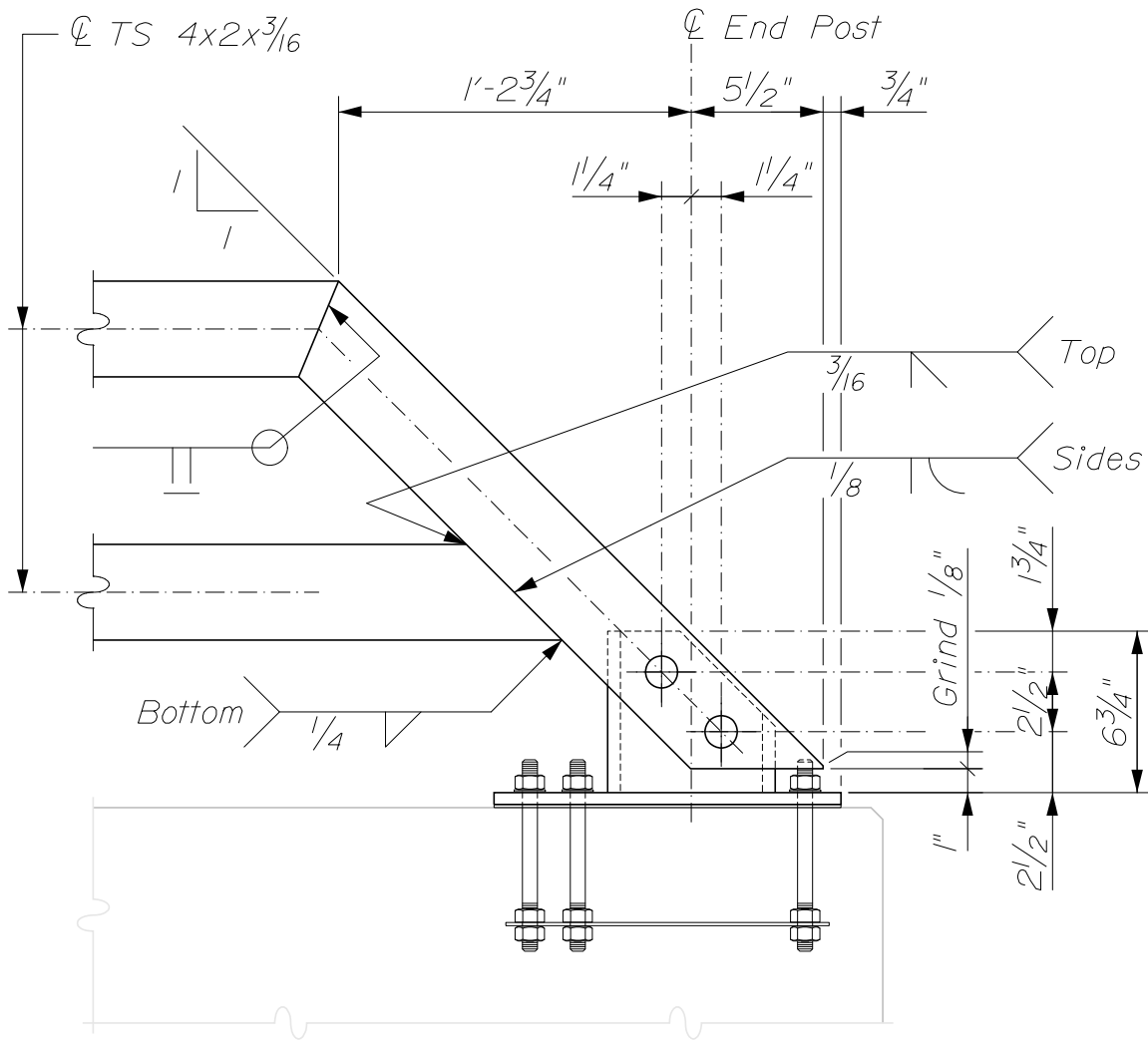

~ RAIL END TREATMENT ~  
 (2 - Bar Bicycle Railing)

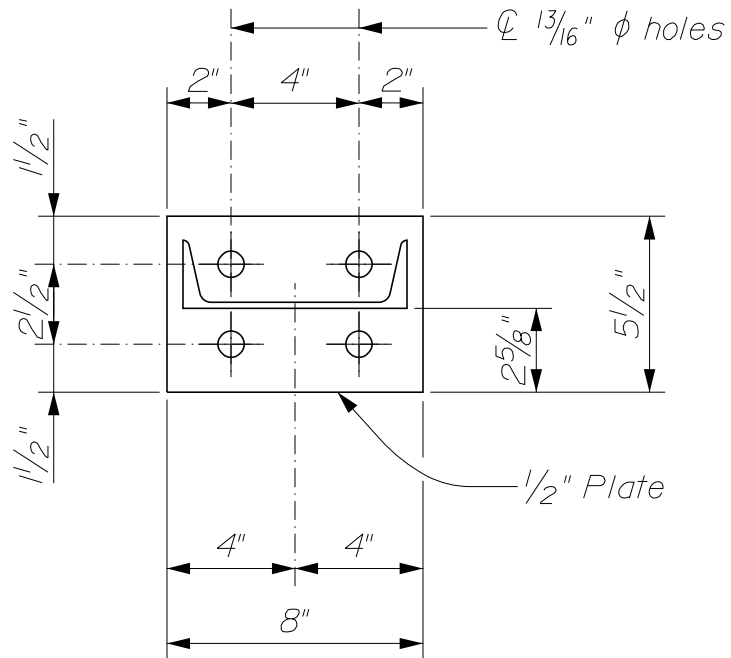

~ POST & BASE PLATE PLAN ~

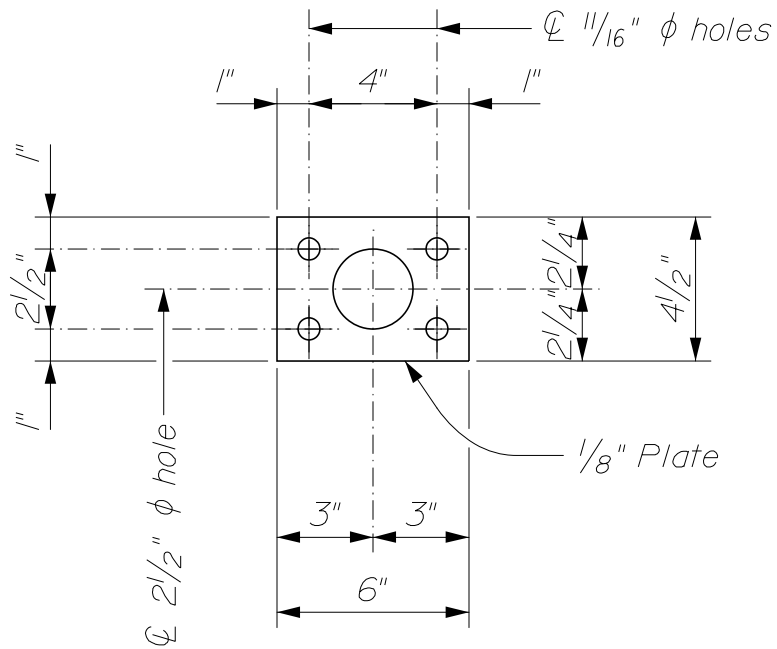

~ SPACER PLATE PLAN ~

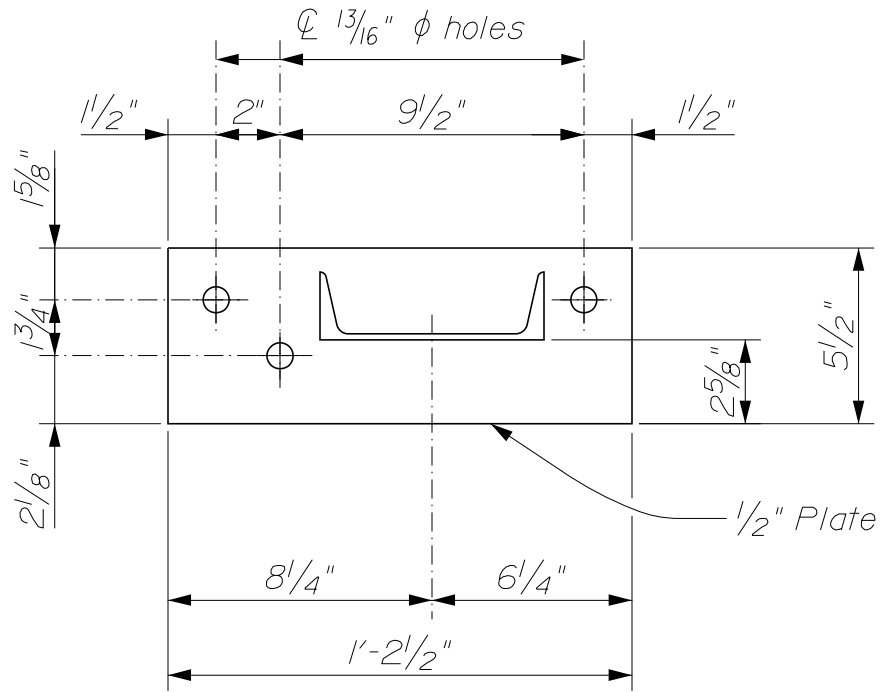

~ END POST & BASE PLATE PLAN ~

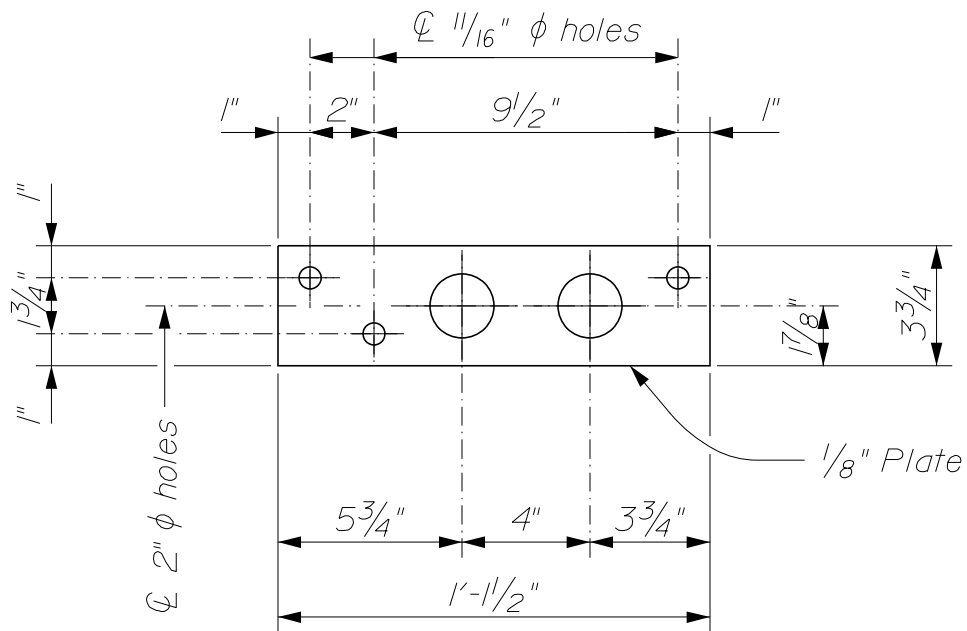

~ END SPACER PLATE PLAN ~

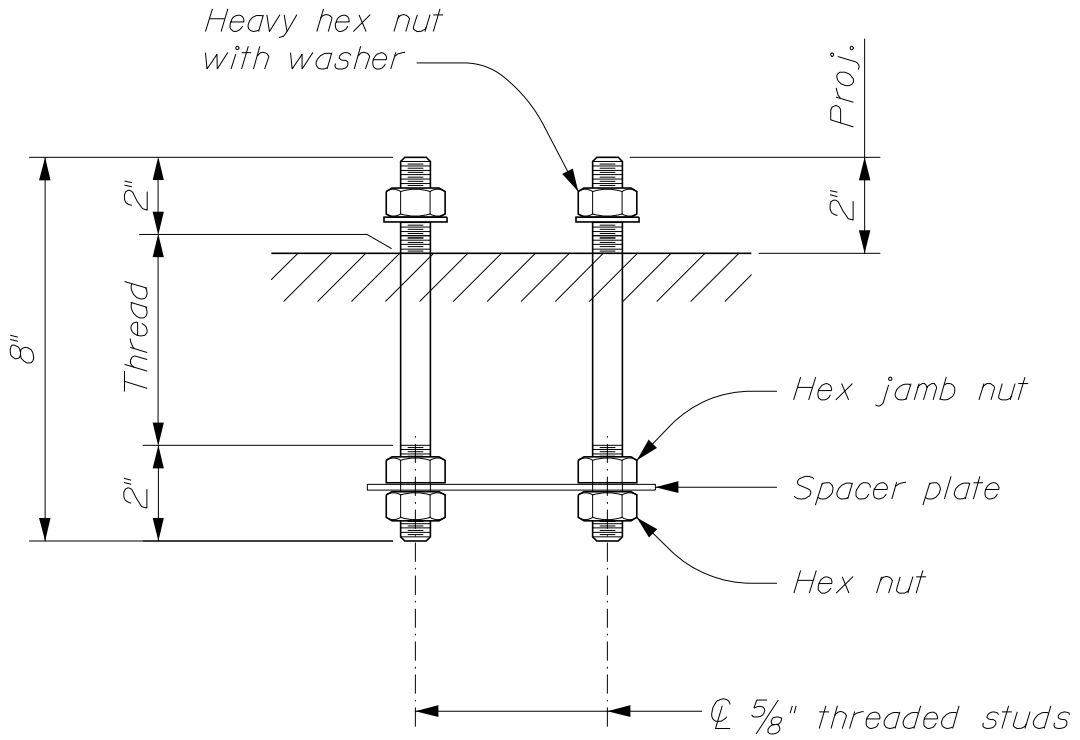

~ ANCHOR BOLT DETAIL ~

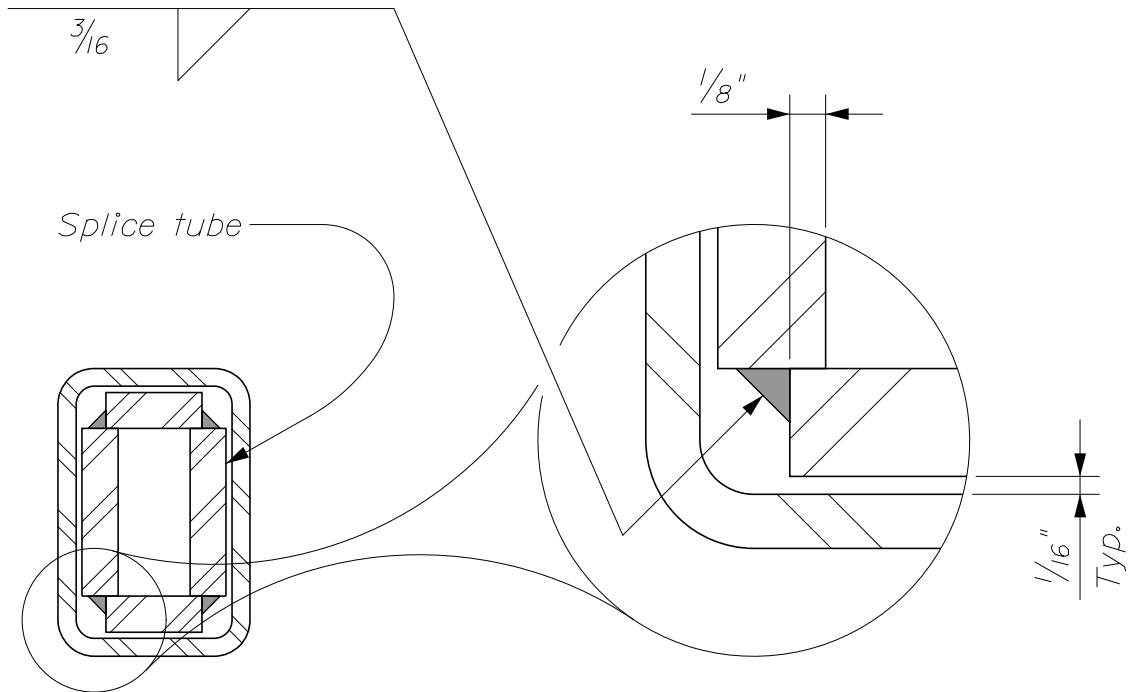

~ RAIL SPLICE SECTION ~

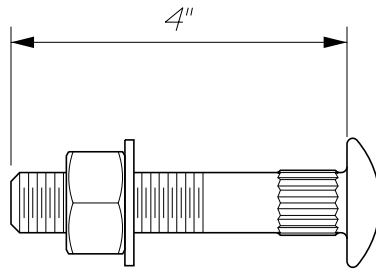

~ RIBBED NECK BOLT ~  
(with washer & lock nut)

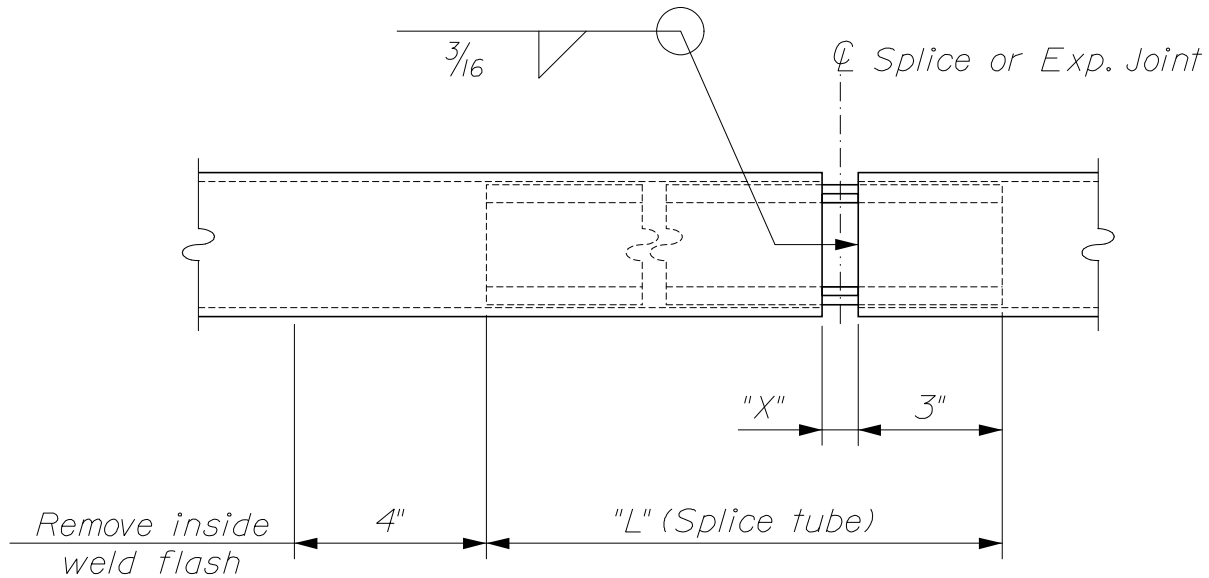

~ RAIL BAR SPLICE / EXPANSION JOINT ~

RAIL BAR SPLICE & EXPANSION JOINT TABLE		
"T"	"L"	"X"
Splice	1'-8"	3/4"
≤ 4"	1'-8"	2 1/2"
> 4" ≤ 6 1/2"	2'-0"	4"
> 6 1/2" ≤ 9"	2'-4"	5"
> 9" ≤ 13"	2'-10"	7"

"T" = Total Movement

SPLICE TUBE (1 - Bar Railing)	
Top & Bot. Plates	Bar 1x3/8 x "L"
Side Plates	Bar 1 3/4 x 3/8 x "L"

SPLICE TUBE (2 - Bar Railing)	
Top & Bot. Plates	Bar 1x3/8 x "L"
Side Plates	Bar 2 3/4 x 3/8 x "L"

## BARRIER - MOUNTED STEEL BRIDGE RAILING

507(38)

NOTES:

1. All work and materials shall conform to the provisions of Standard Specifications Section 507 - Railings.
2. All exposed cut or sheared edges shall be rounded and free of burrs.
3. All parts shall be galvanized after fabrication in accordance with AASHTO M III (ASTM A123), except that hardware shall meet the requirements of AASHTO M 232 (ASTM A153) or ASTM F2329. Parts shall be blast - cleaned prior to galvanizing in accordance with SSPC - SP6.
4. Rail posts shall be set normal to grade unless otherwise indicated.
5. Lengths of rail bar shall be attached to a minimum of 2 rail posts and to at least 4 posts whenever possible.
6. Rail bar expansion joints shall be provided in any rail bay spanning a superstructure expansion joint. Expansion joint width shall be "X" at 45 °F and will be adjusted as directed by the Resident.
7. Holes for ribbed - neck bolts shall be field - drilled to an appropriate size to produce an interference fit with the bolts.
8. Rail post anchoring nuts shall be tightened to a snug fit and given an additional  $\frac{1}{8}$  turn.
9. All butt joint welds shall have a minimum penetration of 60 percent.
10. If there is a conflict between these Standard Details and the Design Drawings, the requirements of the Design Drawings shall be followed.

MATERIALS:

Rail bars.....ASTM A500  
All other shapes & plates.....AASHTO M 270M/M 270, Grade 36  
Threaded studs, washers &  
exposed heavy hex nuts.....AASHTO M 314, Grade 105  
All other bolts & nuts.....ASTM A307, Grade C

BARRIER - MOUNTED STEEL BRIDGE RAILING

507(39)

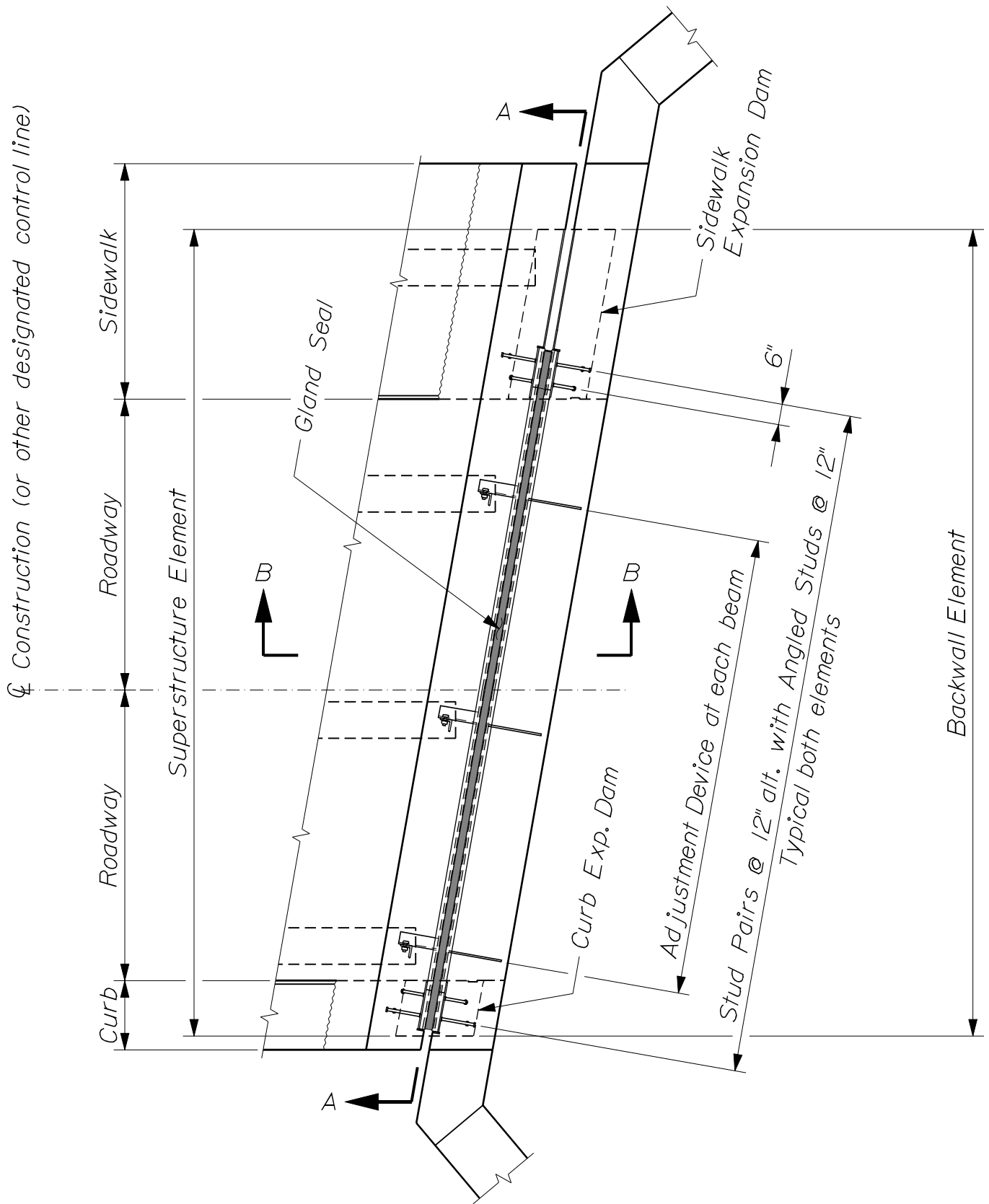

~ EXPANSION DEVICE PLAN ~  
 (Typical installation)

EXPANSION DEVICE - GLAND SEAL  
 520(01)

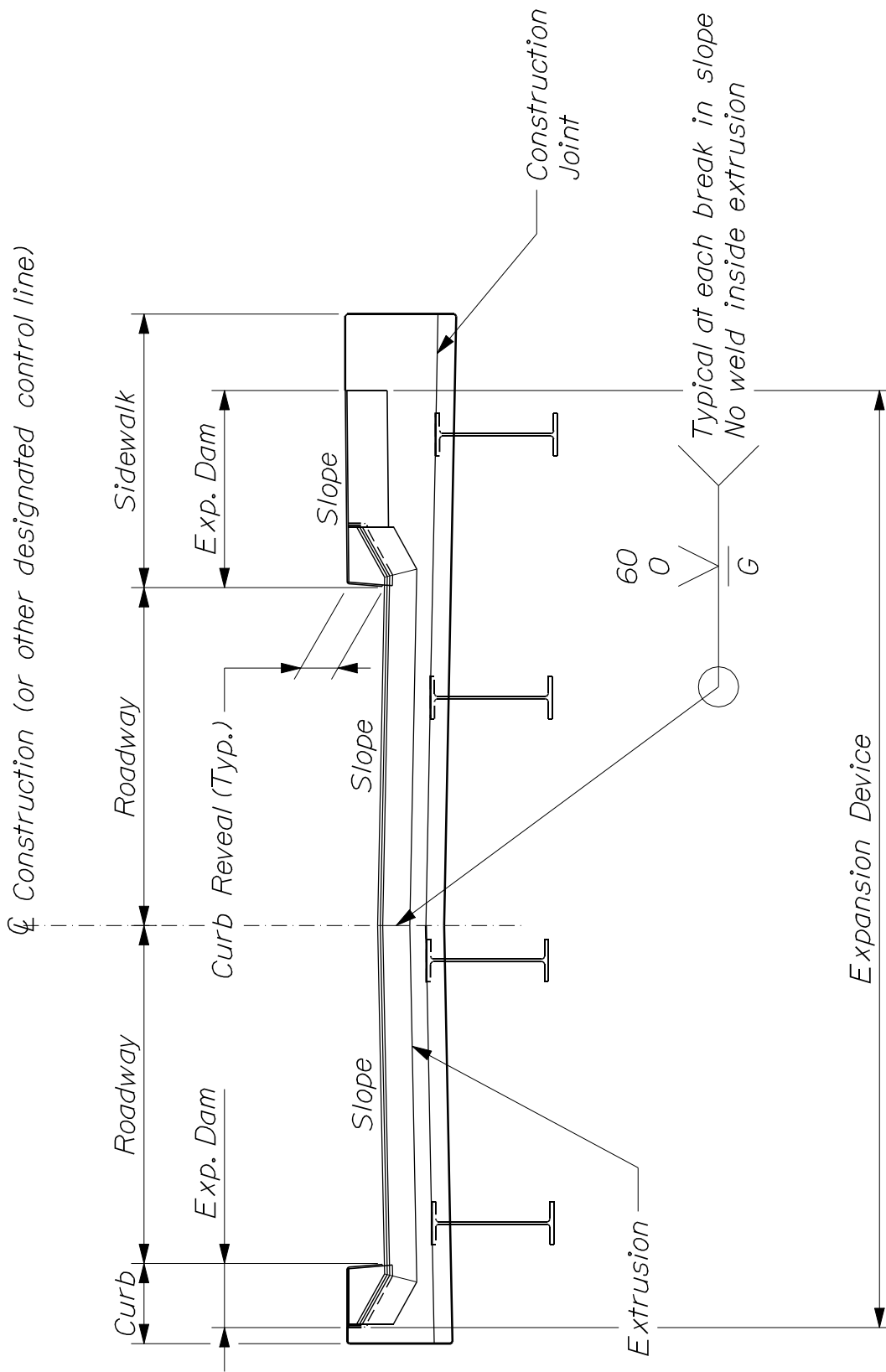

~ SECTION A - A ~

EXPANSION DEVICE - GLAND SEAL  
520(02)

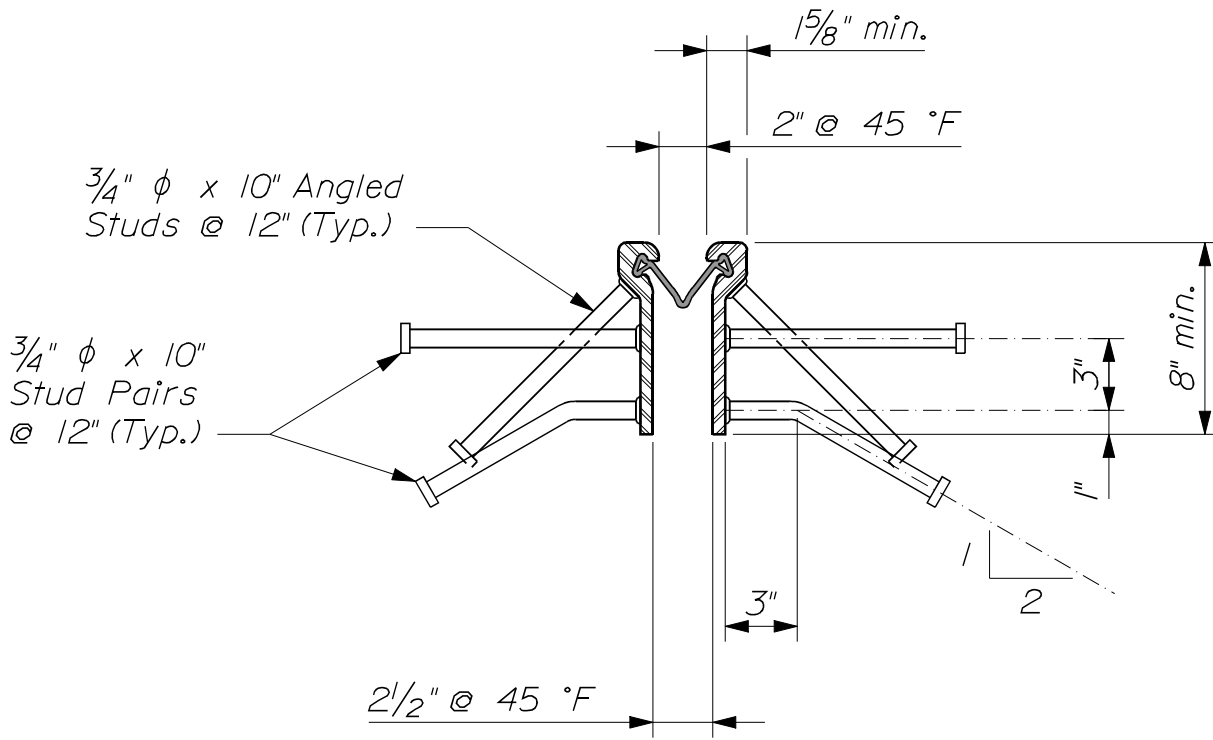

~ TYPICAL SECTION ~ EXPANSION DEVICE ~

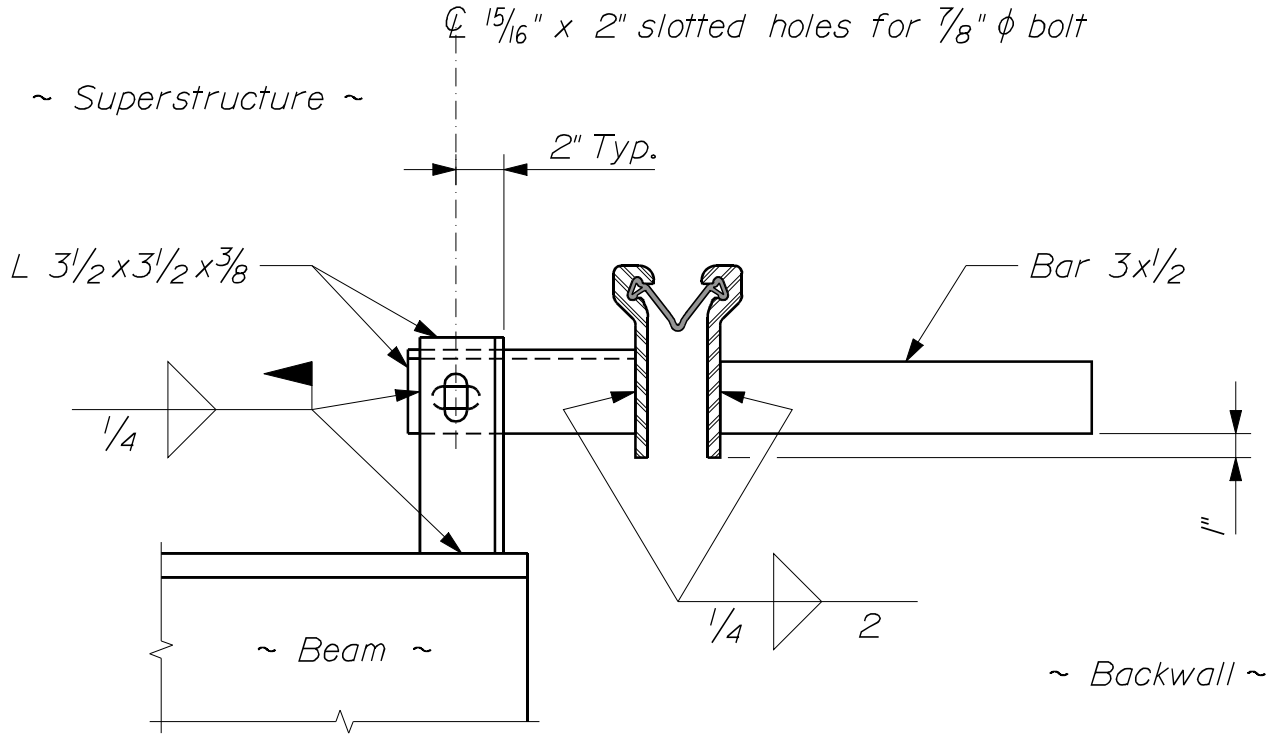

~ ADJUSTMENT DEVICE DETAIL ~

EXPANSION DEVICE - GLAND SEAL  
 520(03)



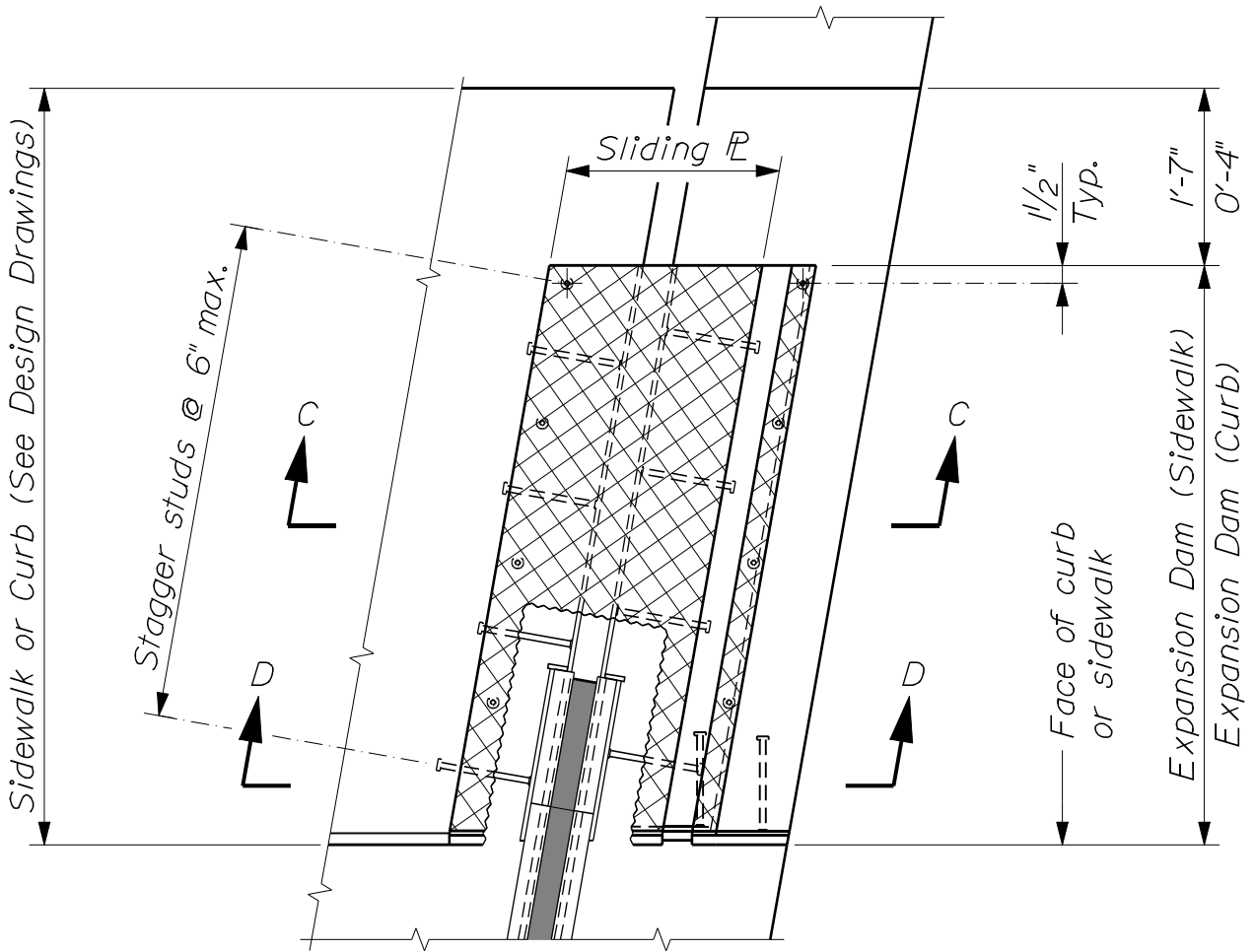

~ EXPANSION DAM PLAN ~

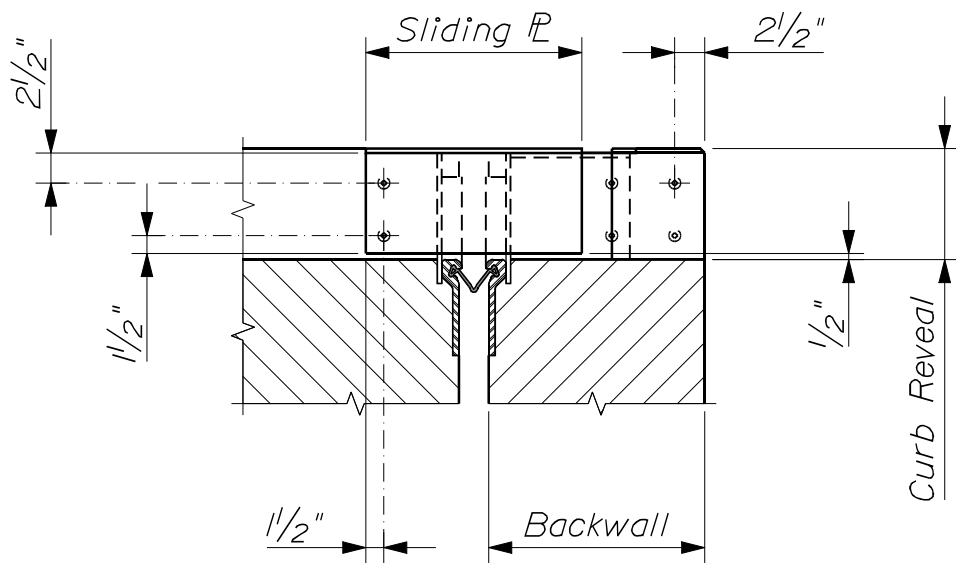

~ EXPANSION DAM ELEVATION ~

EXPANSION DEVICE - GLAND SEAL  
520(05)

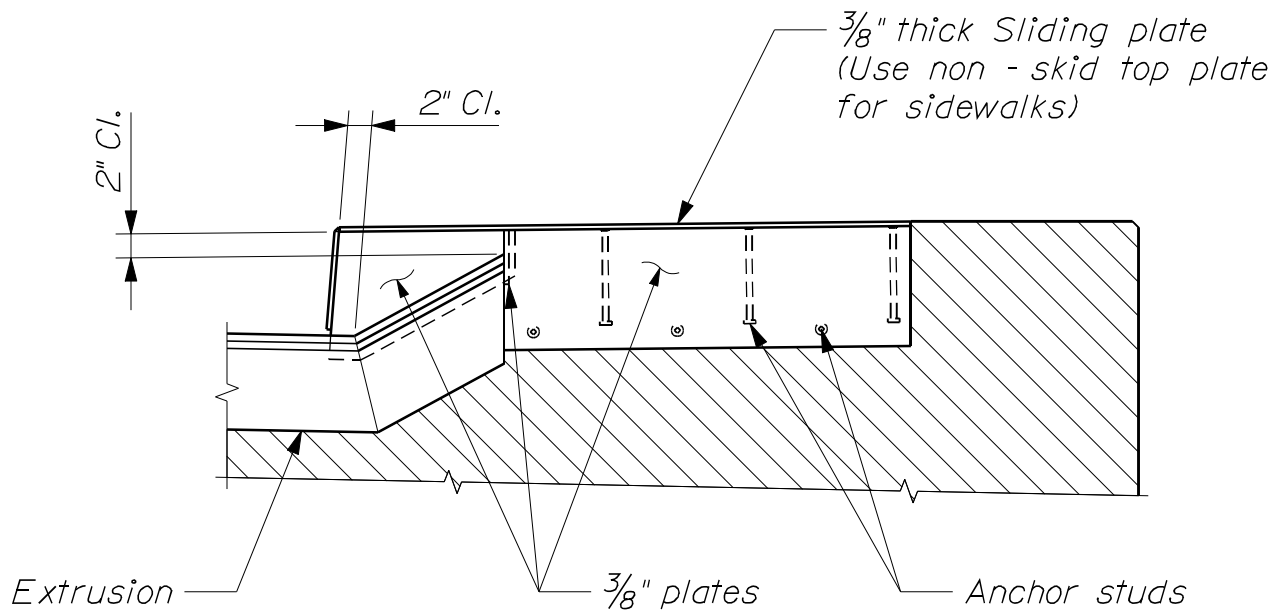

~ EXPANSION DAM SECTION ~

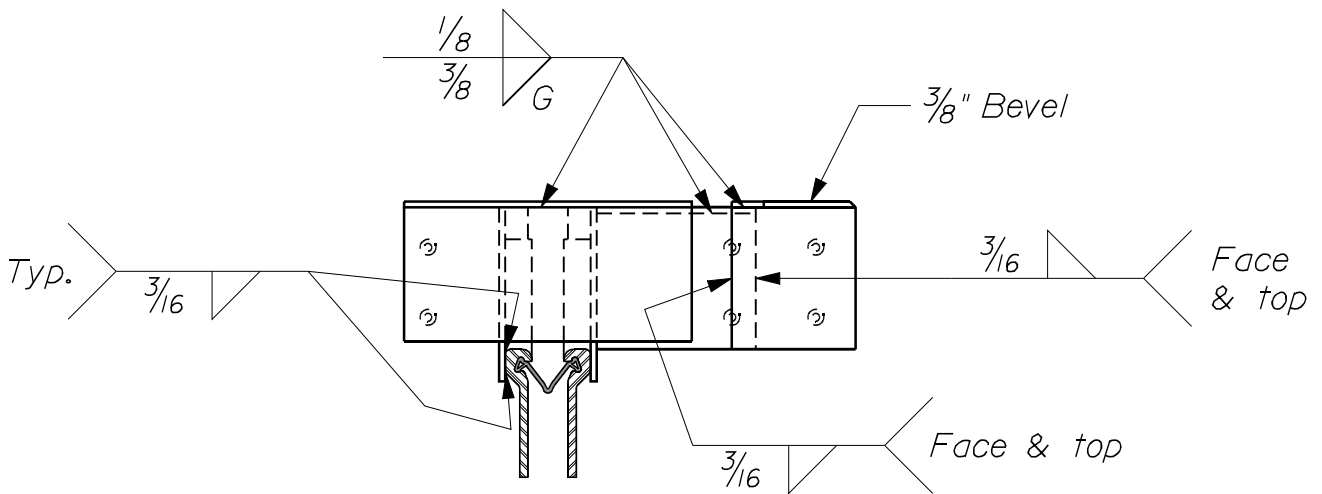

~ WELDING DETAIL ~

EXPANSION DEVICE - GLAND SEAL  
 520(06)



*NOTES:*

- 1. Each "Expansion Device - Gland Seal" consists of one backwall element and one superstructure element (or two superstructure elements over piers) with expansion dams as required.*
- 2. Refer to Design Drawings for dimensions, slopes, skew and all other information necessary to fabricate and install each Expansion Device.*
- 3. The Expansion Device shall be fabricated to be installed normal to grade.*
- 4. Anchor studs shall be installed using automatically timed stud welding equipment.*
- 5. The Expansion Device shall be set to an opening of two inches in the fabrication shop. The joint opening shall be adjusted for temperature in the field at the time of installation using the following formula:*

$$0.00008 \times "D" \times "\Delta T" = \text{Adjustment (in inches)}$$

*"D" is the distance in feet between the backwall and the nearest fixed bearings (for joints at abutments) or between the fixed bearings at either side of the expansion joint (for joints at piers). " $\Delta T$ " is the difference between the temperature of the structure and 45 °F.*

*A structure temperature above 45 °F will result in a smaller joint opening.*

- 6. Welding to reinforcing steel will be allowed in the top of the abutment backwall above the block - out joint.*
- 7. The slab and backwall concrete shall be in place before the Expansion Device is fixed in position. No allowance for movement due to dead load deflection is necessary.*
- 8. The concrete in the block - out may be placed with the curb / sidewalk concrete. An approved epoxy bonding agent shall be applied to all vertical surfaces of the block - out before making the final concrete placement.*
- 9. If there is a conflict between these Standard Details and the Design Drawings, the requirements of the Design Drawings shall be followed.*

*MATERIALS:*

*All shapes and plates ..... AASHTO M 270M/M 270, Grade 36*

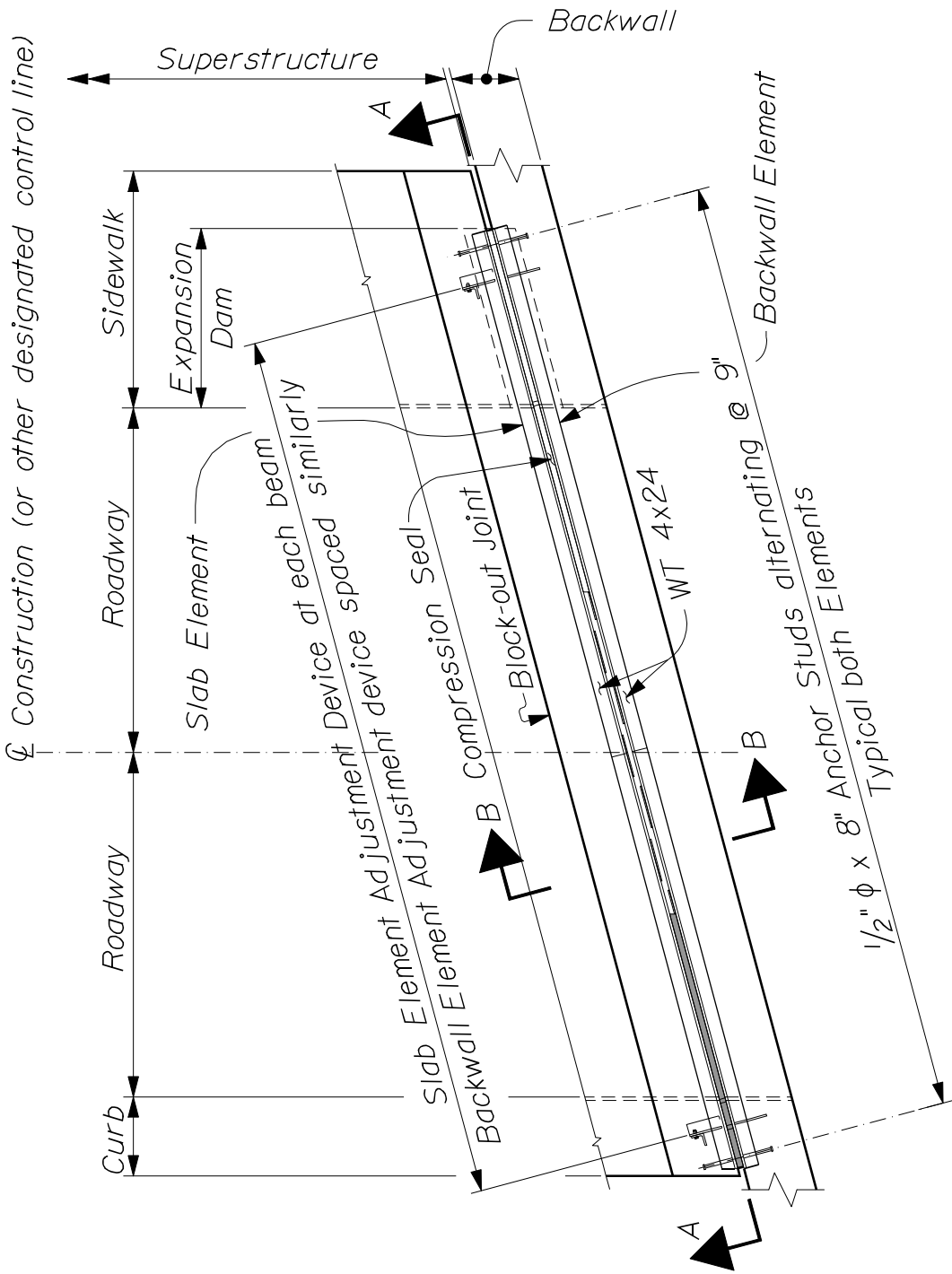

-- PLAN ~ TYPICAL INSTALLATION --  
 (Expansion Dam not shown for clarity)

EXPANSION DEVICE - COMPRESSION SEAL  
 520(09)

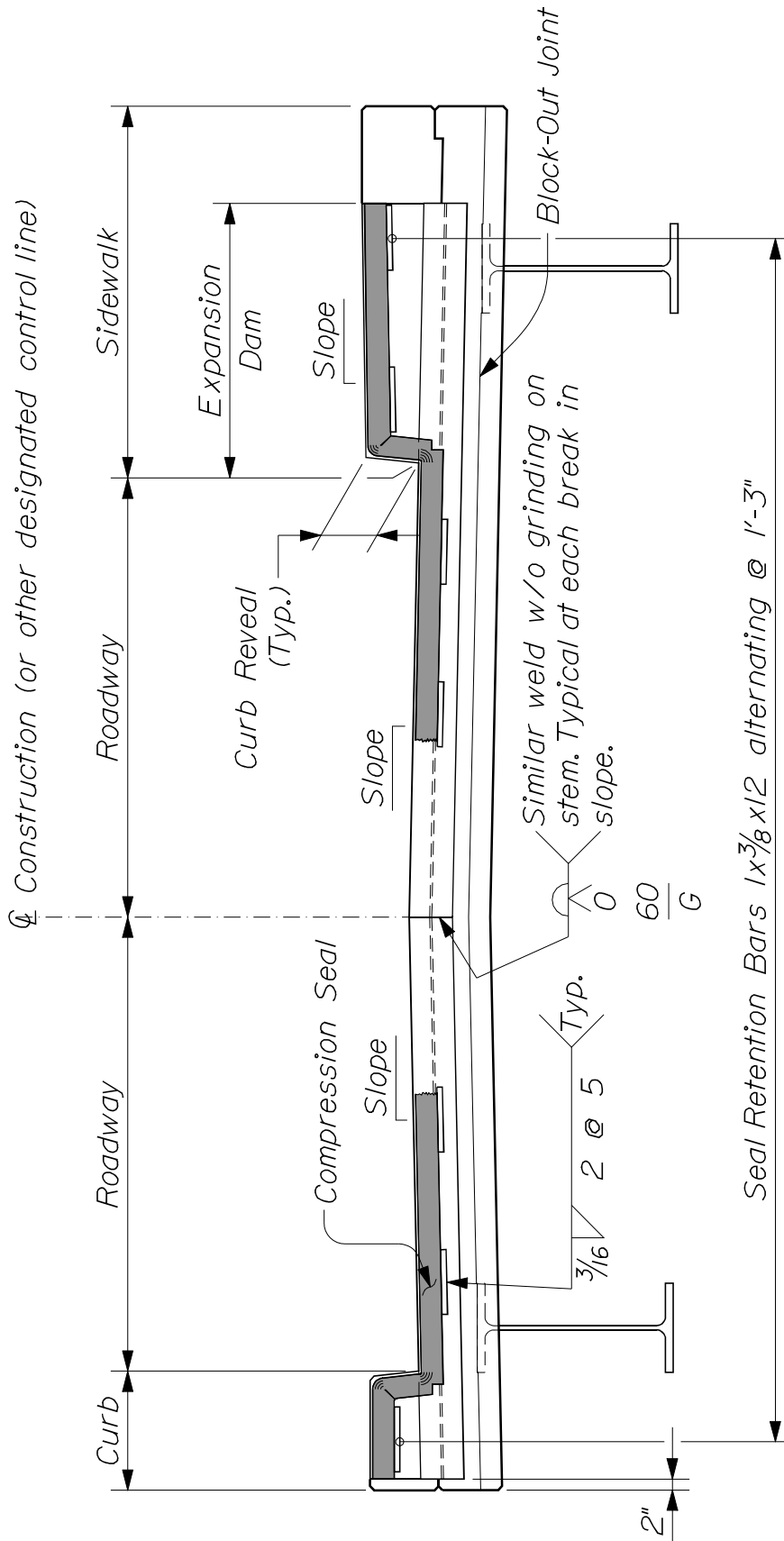

Section A-A / 520(09)

~ ELEVATION ~ TYPICAL INSTALLATION ~

EXPANSION DEVICE - COMPRESSION SEAL  
520(10)

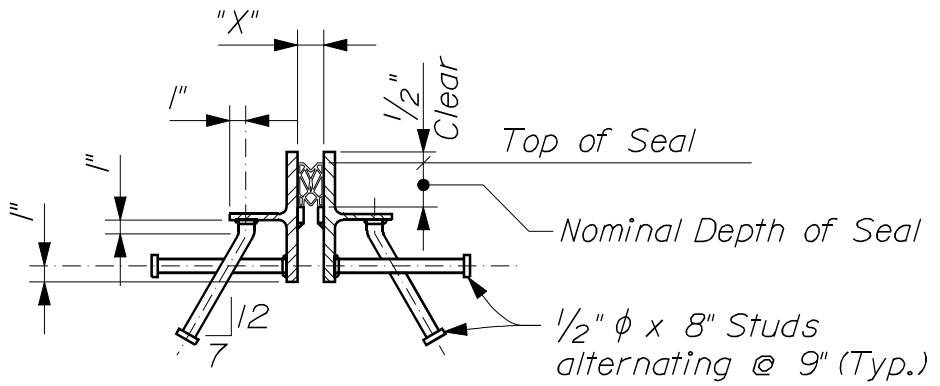

~ TYPICAL SECTION ~

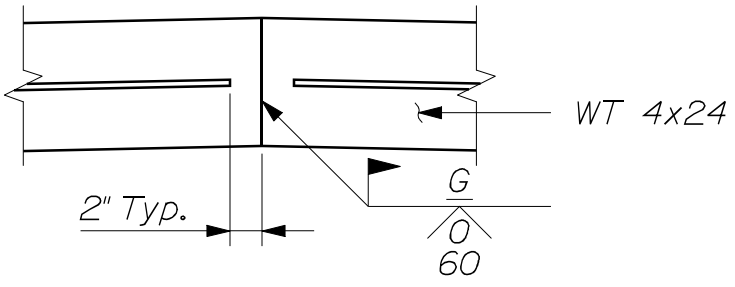

~ JOINT ARMOR FIELD SPLICE ~  
(for Stage Construction)

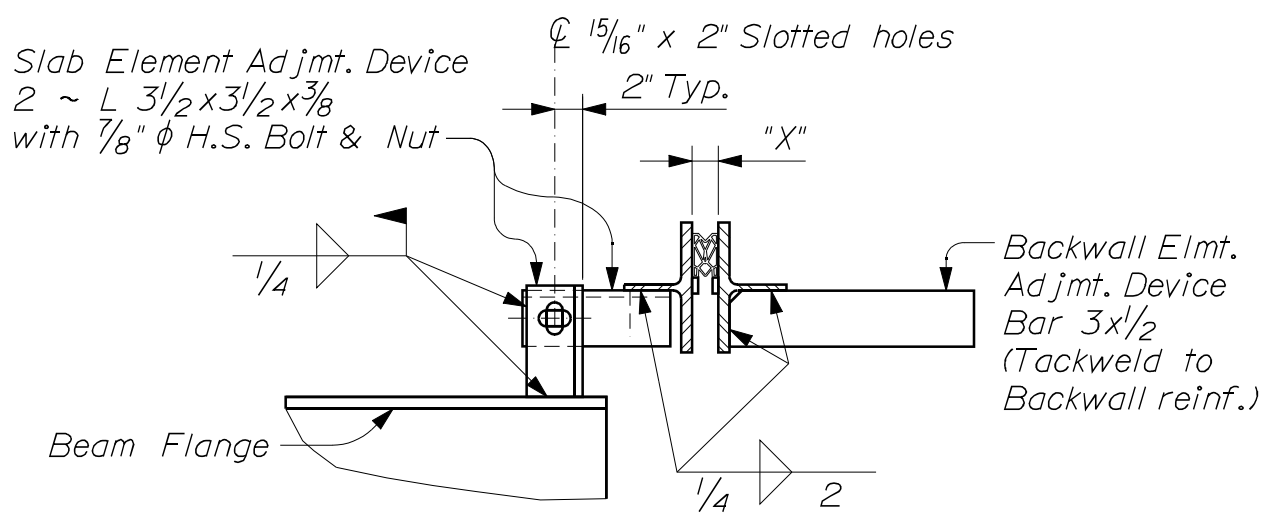

~ ADJUSTMENT DEVICE ~

EXPANSION DEVICE - COMPRESSION SEAL  
520(II)

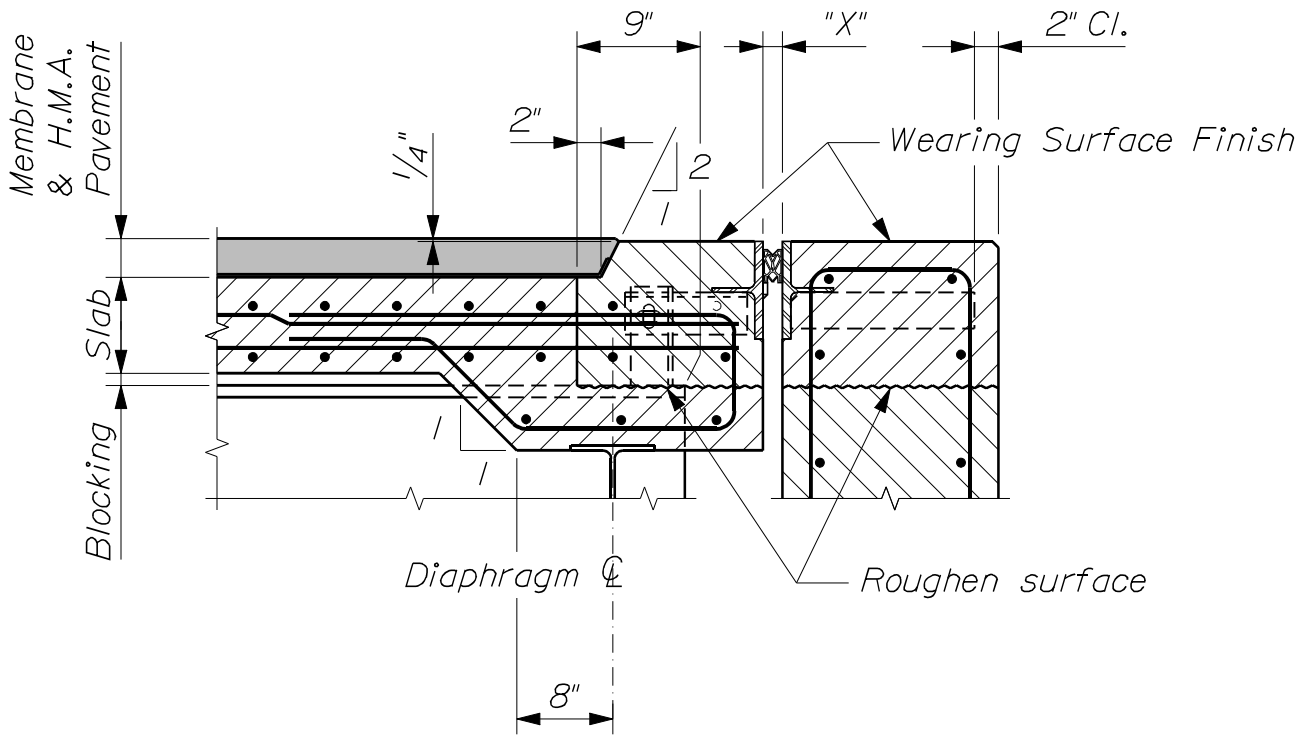

~ SECTION B - B ~  
 (Showing Hot Mix Asphalt Pavement Wearing Surface)

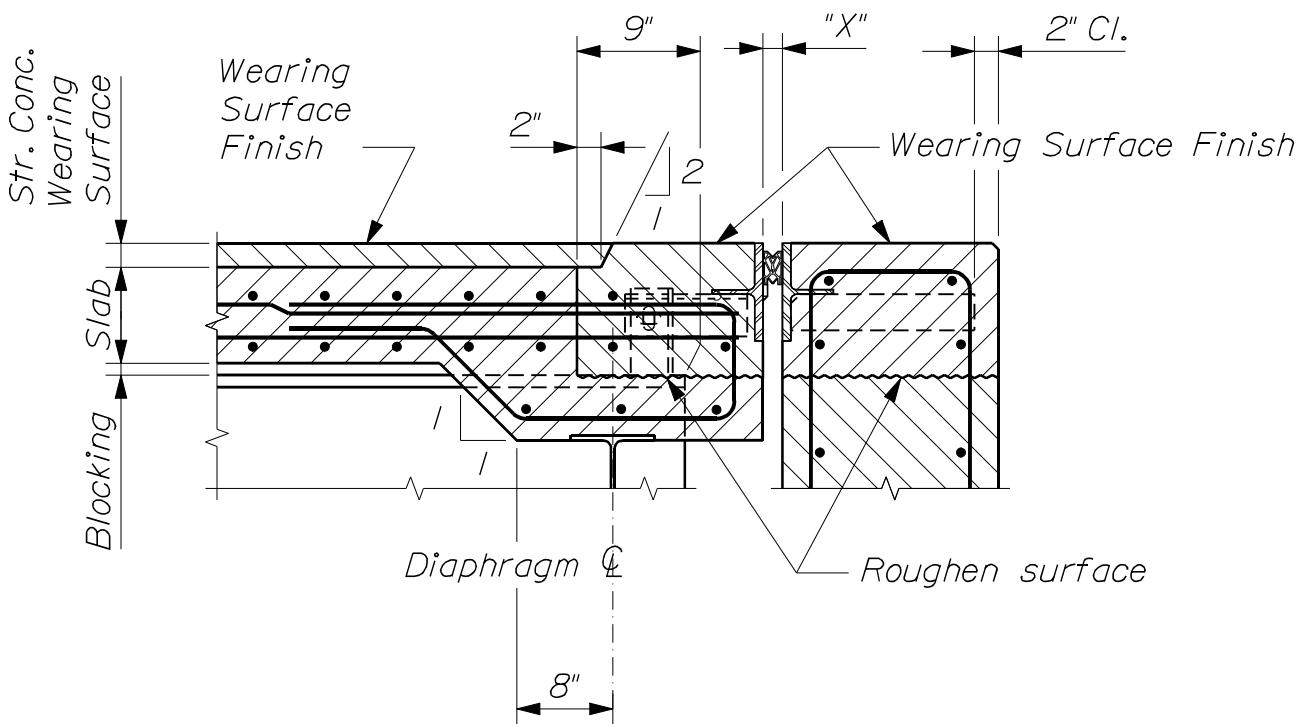

~ SECTION B - B ~  
 (Showing Structural Concrete Wearing Surface)

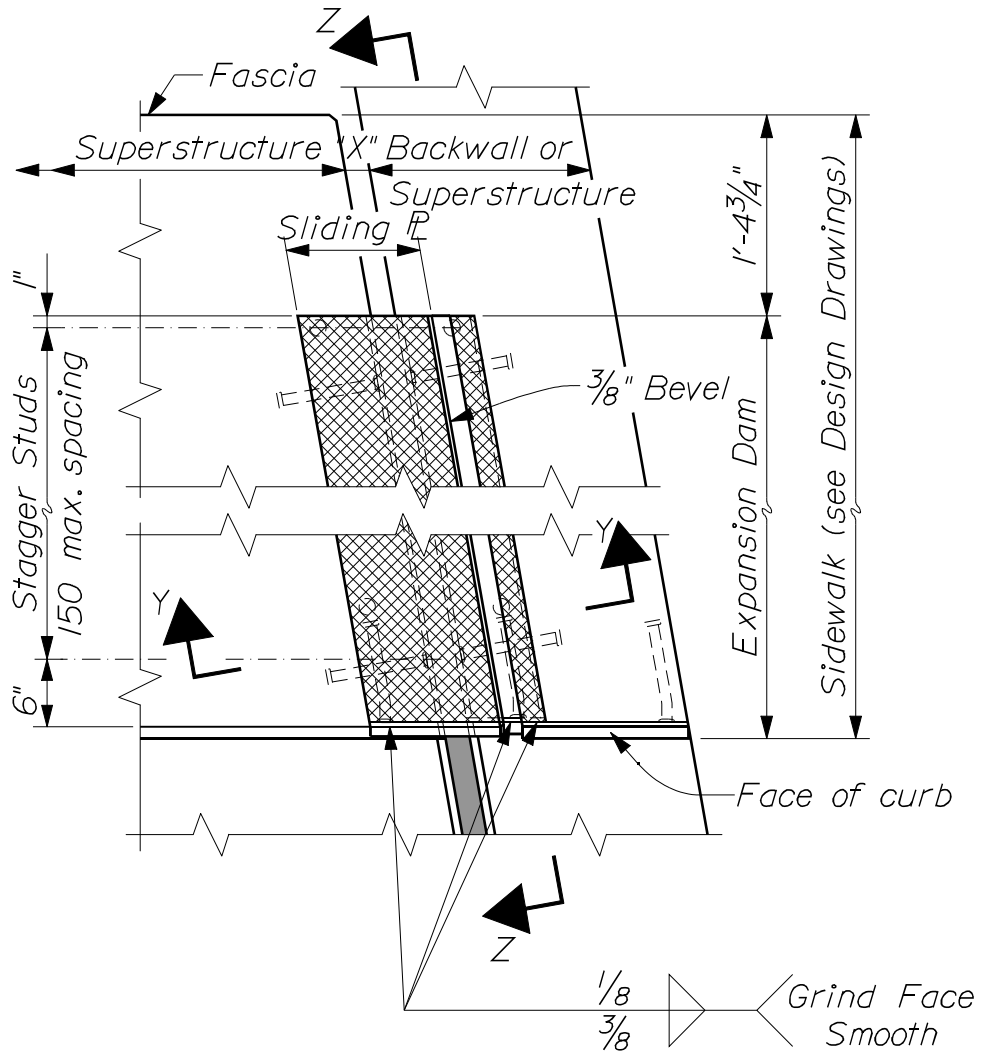

~ PLAN - SIDEWALK EXPANSION DAM ~

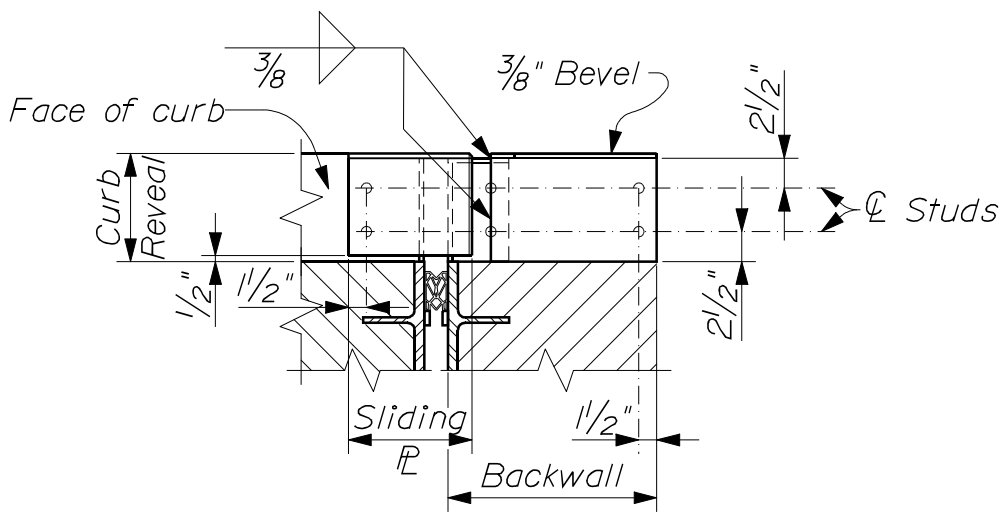

~ ELEVATION - SIDEWALK EXPANSION DAM ~

EXPANSION DEVICE - COMPRESSION SEAL

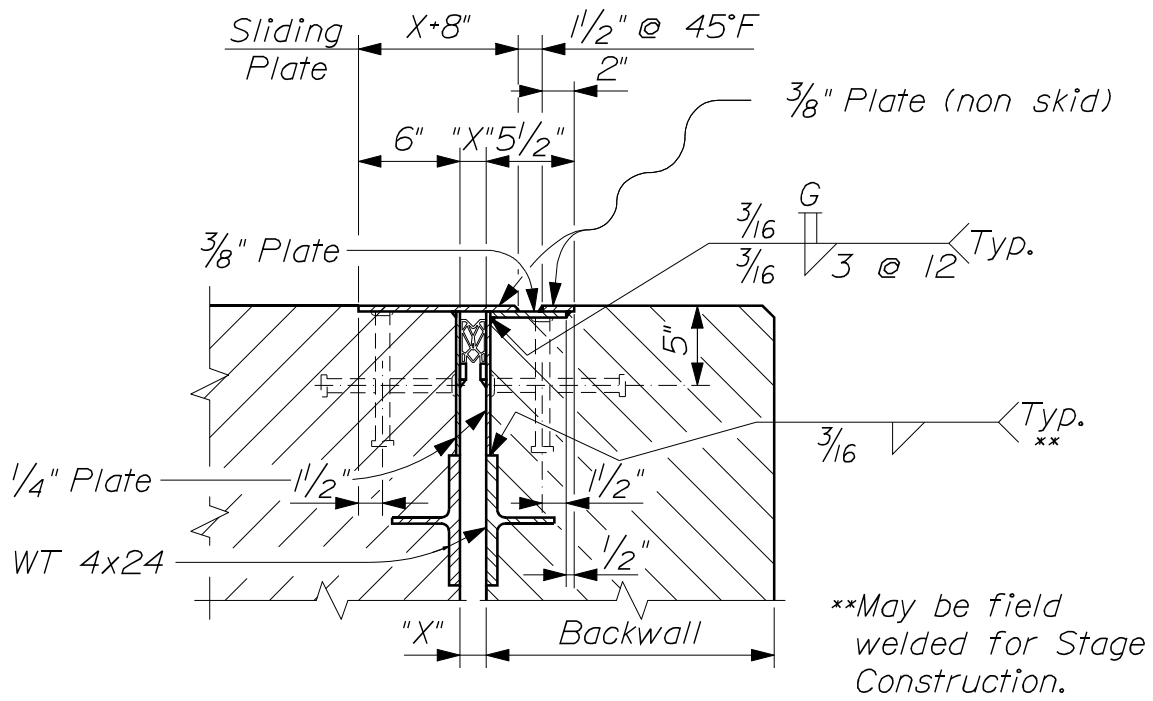

Section Y-Y / 520(13)

Slope of curb plates shall match slope of curb shown on Design Drawings.

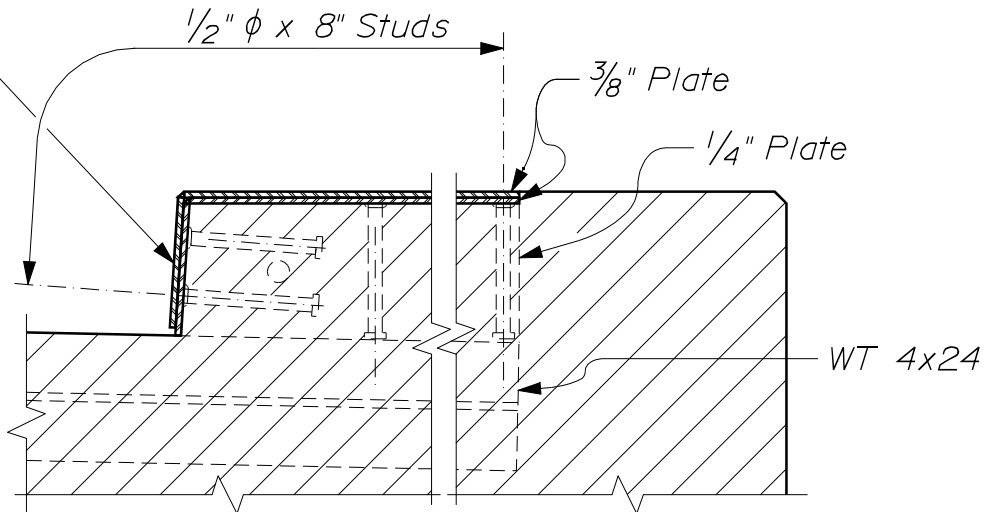

Section Z-Z / 520(13)

~ SIDEWALK EXPANSION DAM SECTIONS ~

EXPANSION DEVICE - COMPRESSION SEAL

520(14)

NOTES:

1. Each "Expansion Device - Compression Seal" consists of one backwall element and one superstructure element (or two superstructure elements over piers) with expansion dams as required.
2. Refer to Design Drawings for dimensions, slopes, skew and all other information necessary to fabricate and install each Expansion Device.
3. The Expansion Device shall be fabricated to be installed normal to grade.
4. Anchor studs shall be installed using automatically timed stud welding equipment.
5. Dimension "X" at 45 °F shall be determined as follows:

$$(0.85 \times \text{nominal seal width}) - \frac{1}{2}MR$$

The Movement Rating (MR) for each seal shall be as determined by MaineDOT for the make and type of seal to be provided. Dimension "X" at 45 °F and the make and type of seal shall be shown on the Shop Detail Drawings.

6. Final adjustment for temperature shall be made in the field according to the "Compression Seal Adjustment Chart" shown on the Design Drawings. The adjustment shall be measured parallel to the centerline of construction.
7. Welding to reinforcing steel will be allowed in the top of the abutment backwall above the block - out joint.
8. The slab and backwall concrete shall be in place before the Expansion Device is fixed in position. No allowance for movement due to dead load deflection is necessary.
9. The concrete in the block - out may be placed with the curb / sidewalk concrete. An approved epoxy bonding agent shall be applied to all vertical surfaces of the block - out before making the final concrete placement.
10. If there is a conflict between these Standard Details and the Design Drawings, the requirements of the Design Drawings shall be followed.

MATERIALS:

All shapes and plates ..... AASHTO M 270M/M 270, Grade 36

**EXPANSION DEVICE - COMPRESSION SEAL**  
520(15)

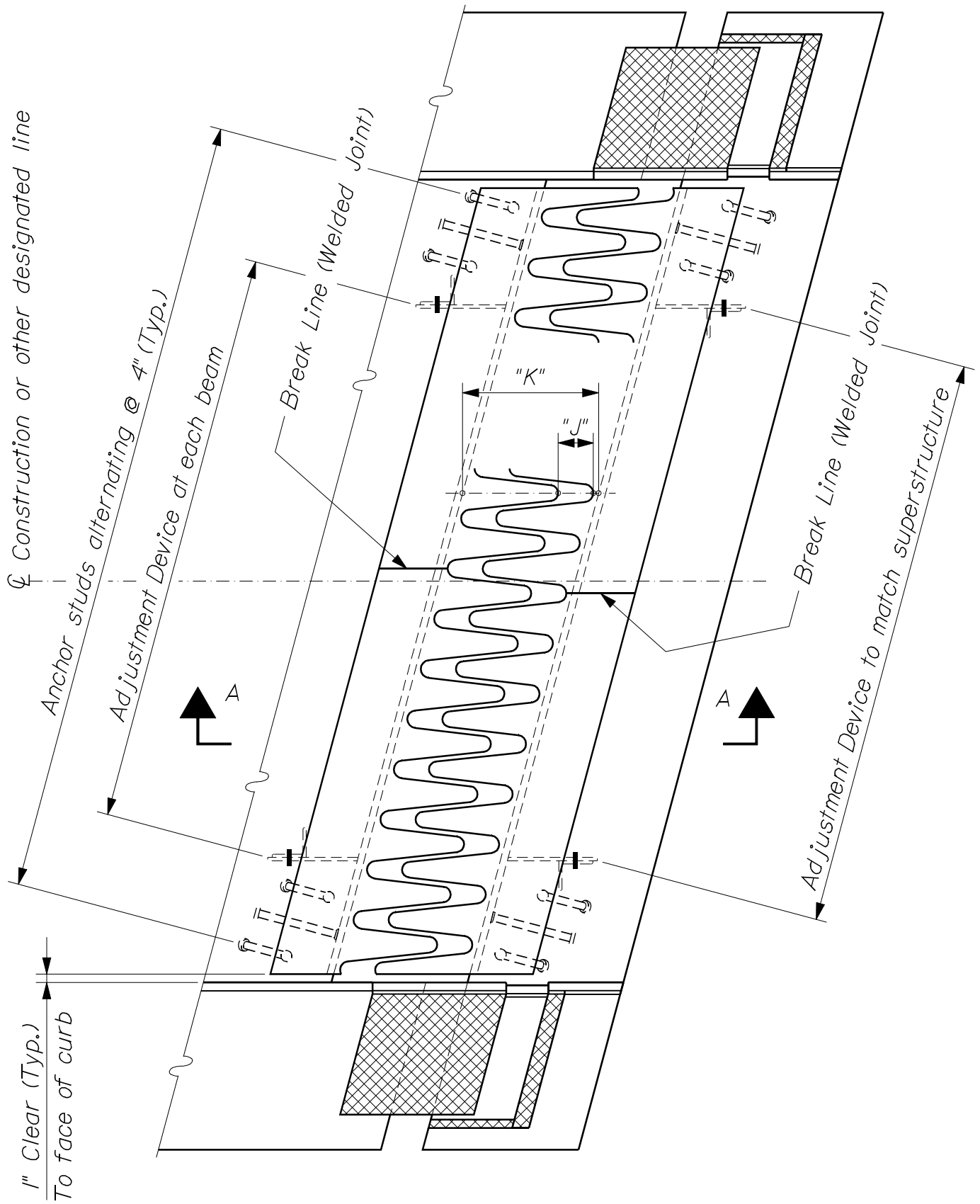

~ FINGER JOINT PLAN ~

EXPANSION DEVICE - FINGER JOINT

52(01)

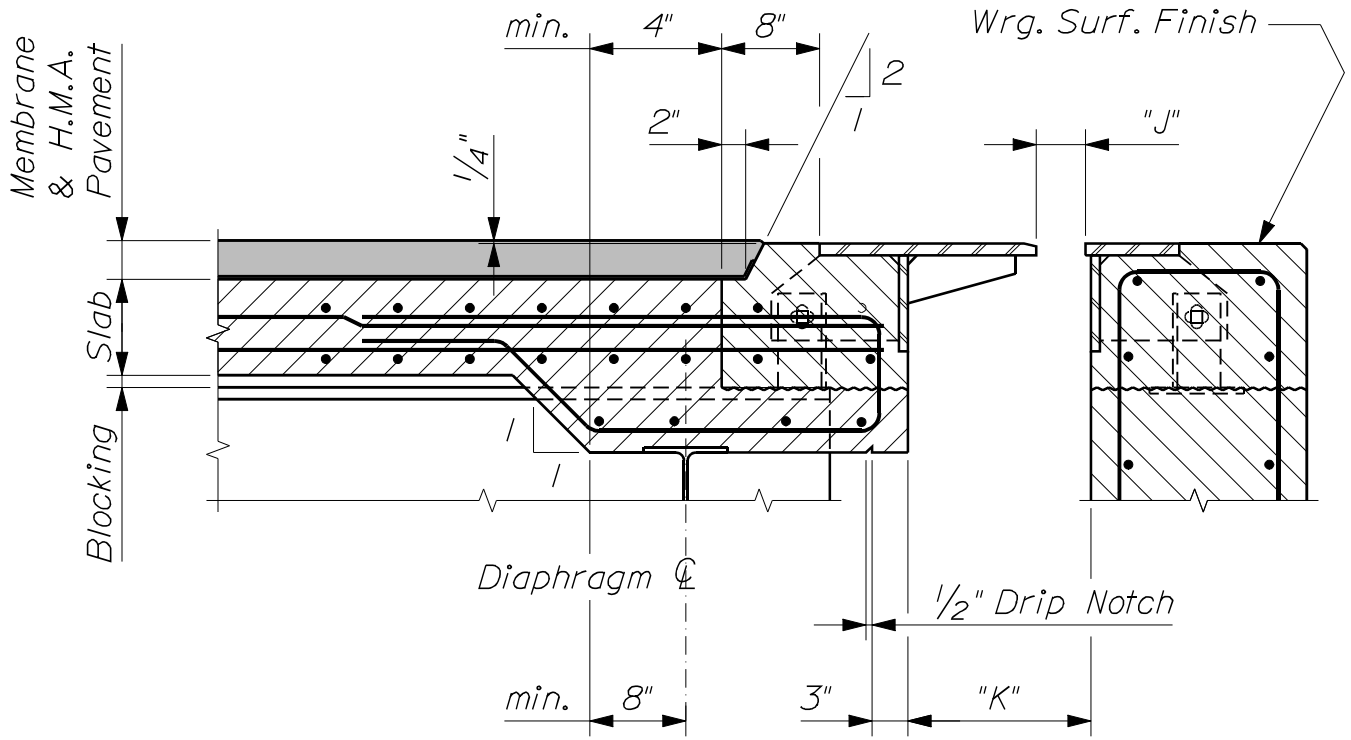

~ SECTION A - A ~  
 (Showing Hot Mix Asphalt Pavement Wearing Surface)

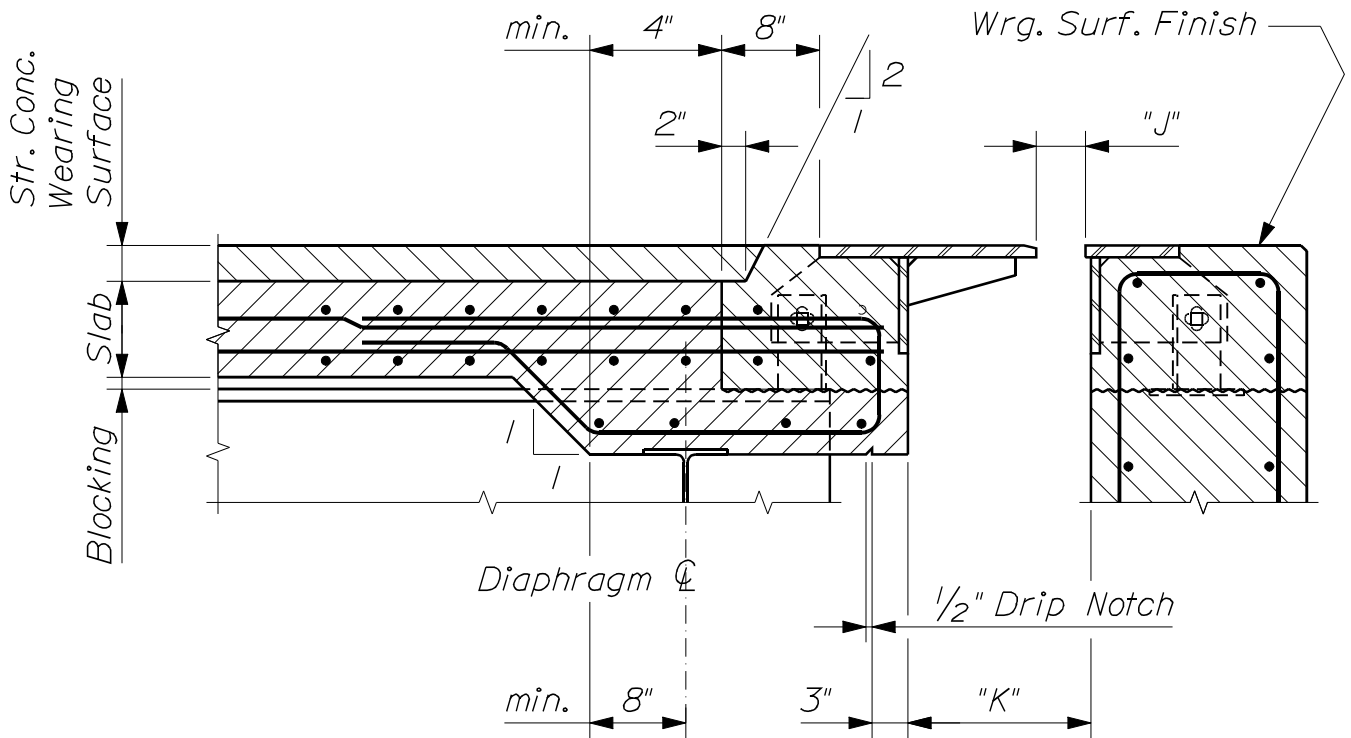

~ SECTION A - A ~  
 (Showing Structural Concrete Wearing Surface)

EXPANSION DEVICE - FINGER JOINT  
 521(02)

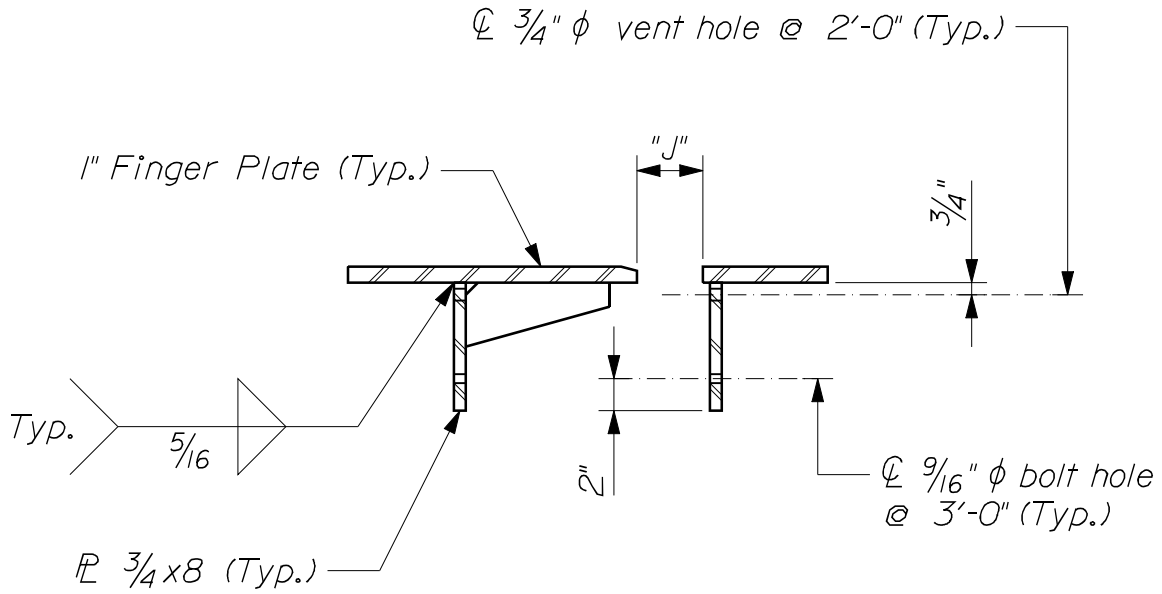

-- TYPICAL FINGER JOINT SECTION --

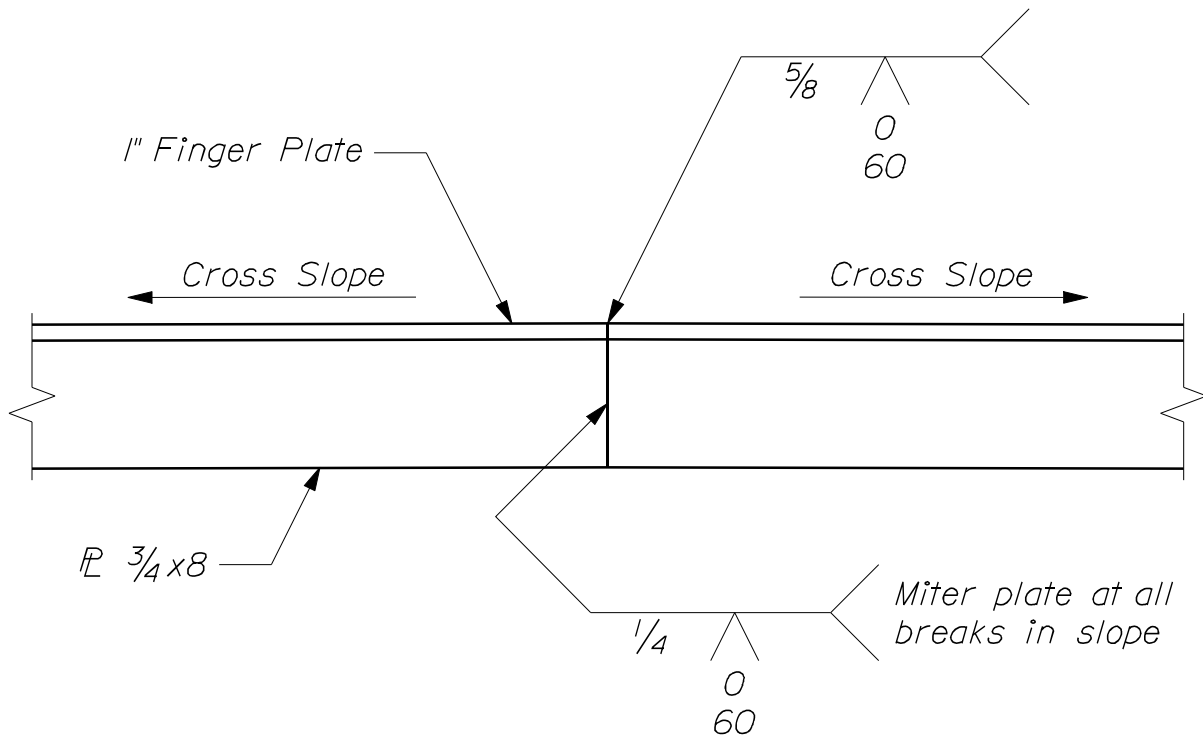

-- FINGER JOINT ELEVATION AT BREAK IN CROSS SLOPE --

EXPANSION DEVICE - FINGER JOINT

521(03)

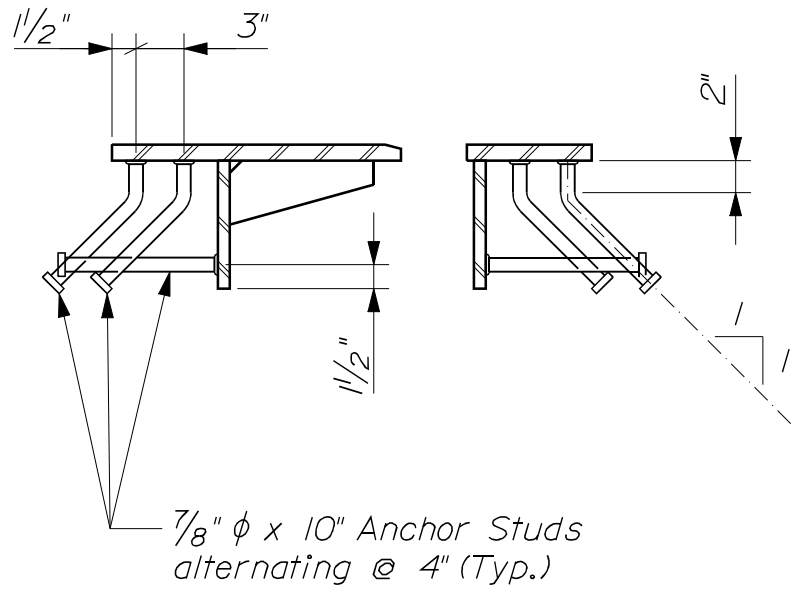

-- ANCHOR STUD DETAIL --

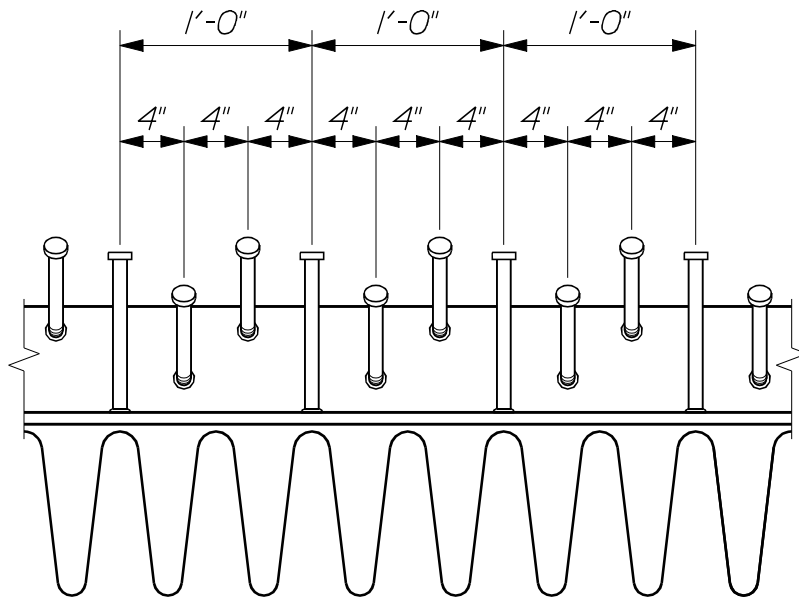

-- ANCHOR STUD LAYOUT PLAN (BOTTOM VIEW) --

EXPANSION DEVICE - FINGER JOINT  
 52(04)

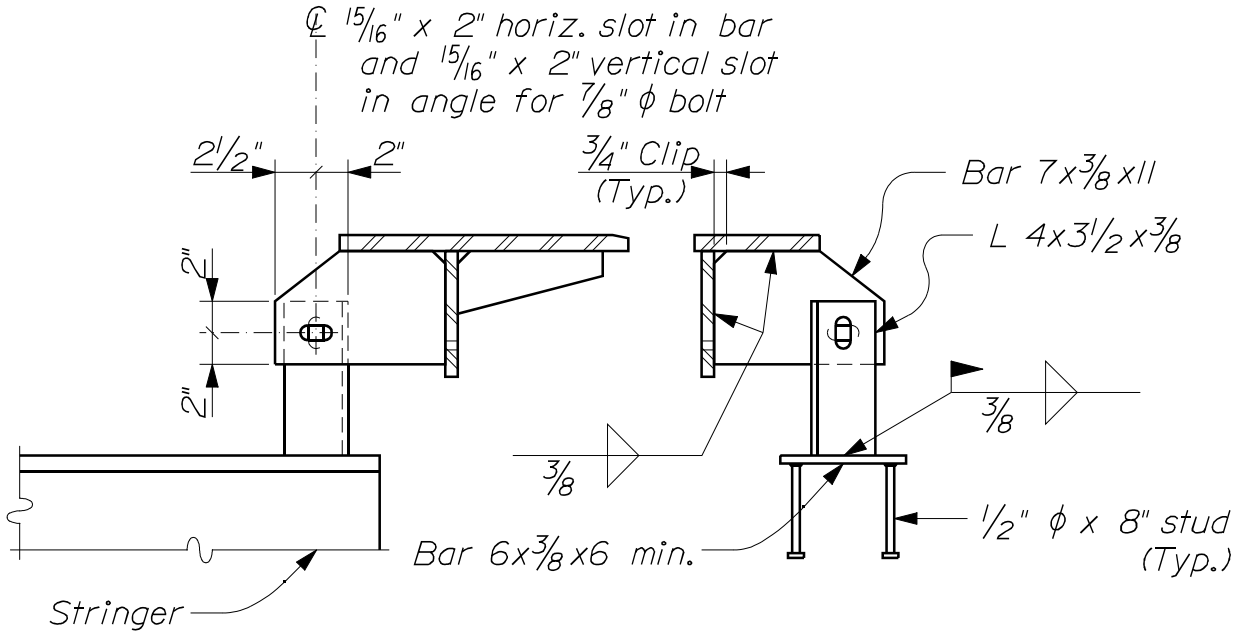

~ ADJUSTMENT DEVICES ~  
 Symmetrical both sides of joint except as shown

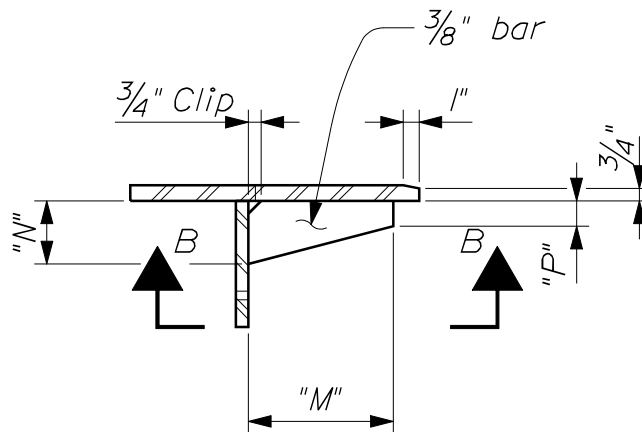

~ FINGER DETAIL ~

EXPANSION DEVICE - FINGER JOINT  
 521(05)

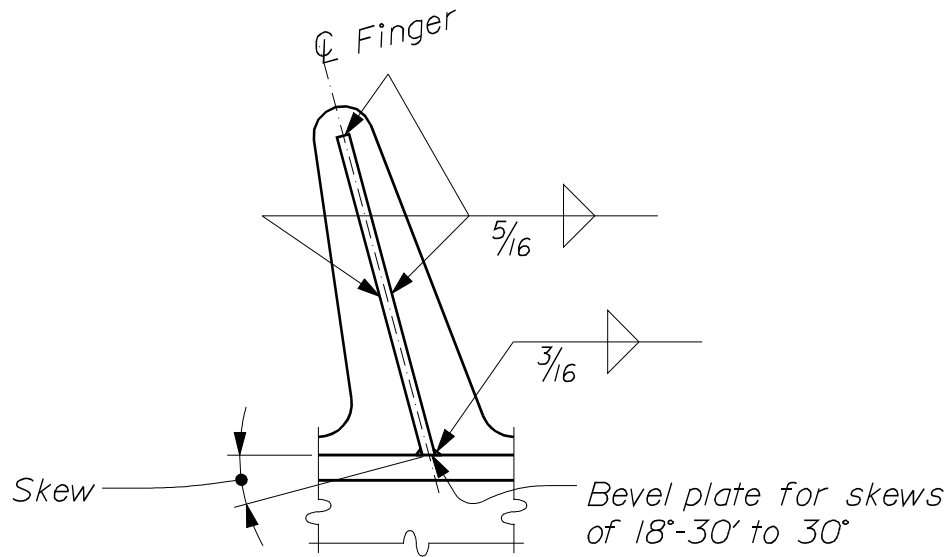

~ VIEW B-B ~  
 Skew 0° to 30°

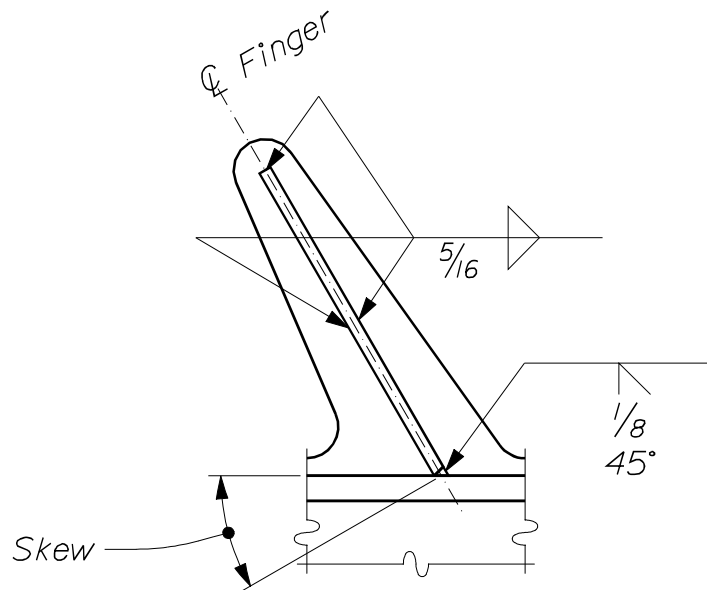

~ VIEW B-B ~  
 Skew over 30°

EXPANSION DEVICE - FINGER JOINT  
 521(06)

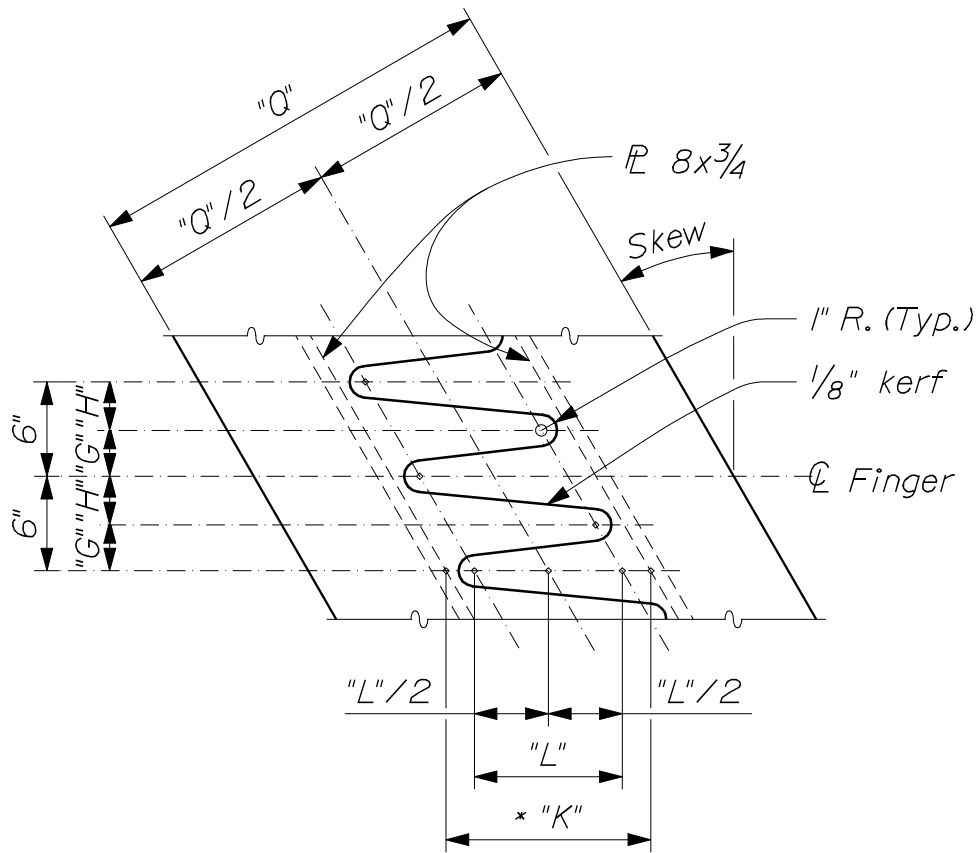

~ FINGER CUTTING DETAIL ~  
 (Skew back on left)

Note; Cut from one plate and match mark  
 \* "K" is "K" dimension prior to cutting plate

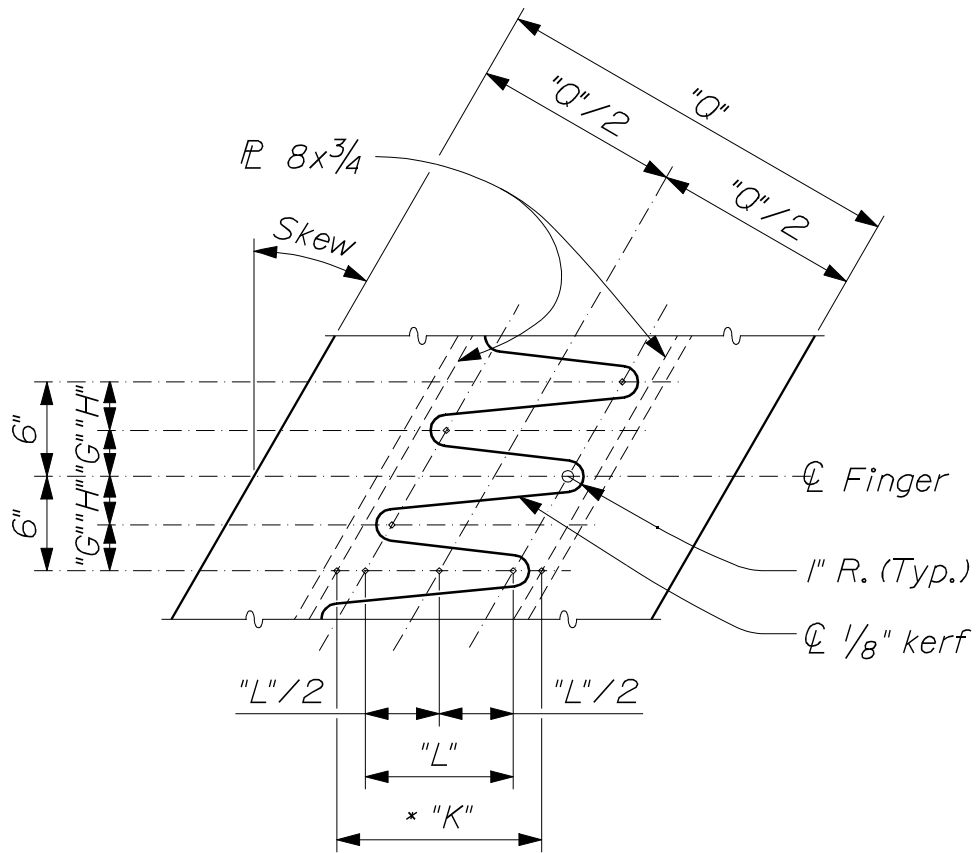

~ FINGER CUTTING DETAIL ~  
 (Skew ahead on left)

Note; Cut from one plate and match mark  
 $\times$  "K" is "K" dimension prior to cutting plate



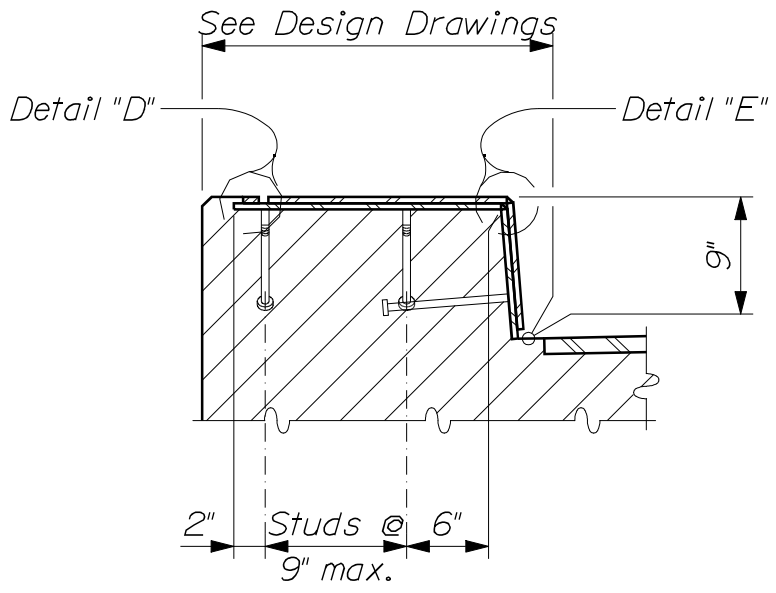

~ SECTION C-C ~

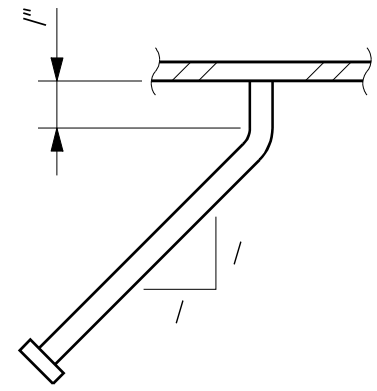

~ BENT STUD DETAIL ~

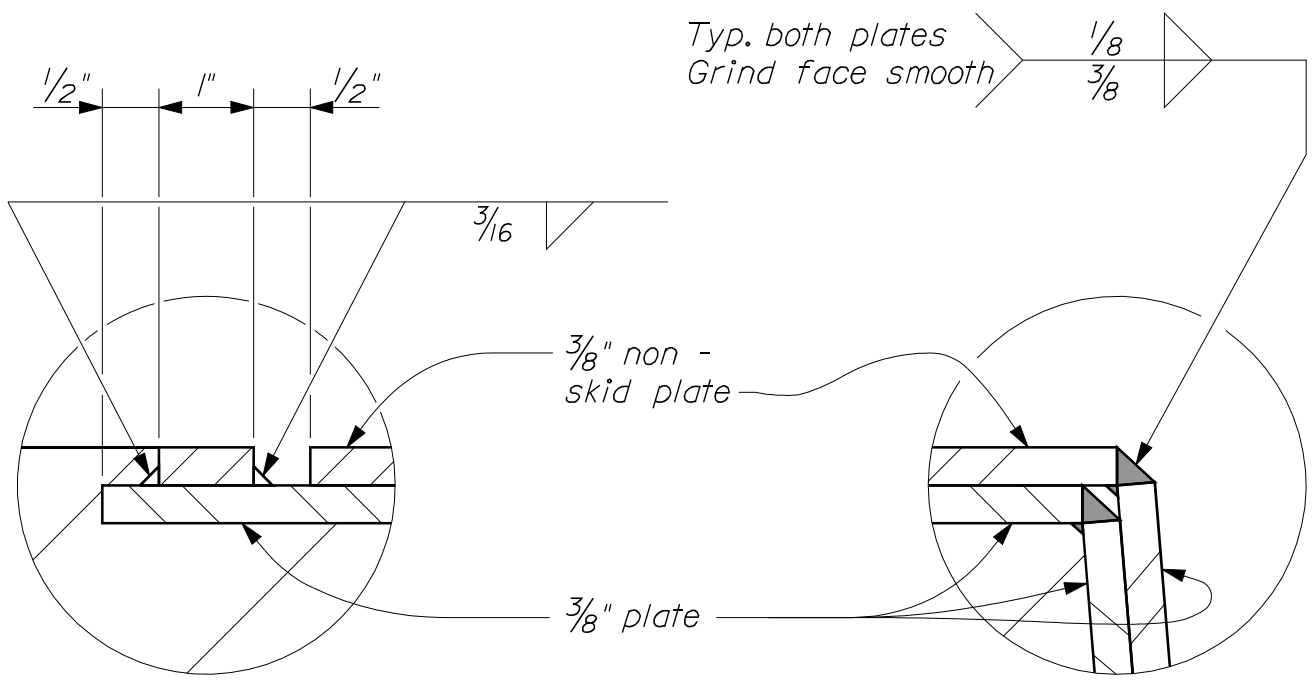

~ DETAIL "D" ~

~ DETAIL "E" ~

EXPANSION DEVICE - FINGER JOINT

TABLE OF DIMENSIONS

Type	Exp. Length	Skew	* "K"	"L"	"G"	"H"	"K" @ 45°	"J" @ 45°	"M"	"N"	"P"	"Q"	"X" @ 45°	
A	100' to 280'	0° to 5°	7"	4"	3"	3"	9"	2 1/8"	--	--	--	21"	3"	
		> 5° to 10°	7 1/4"	4 1/4"	2 7/8"	3 1/8"	9 1/4"	2 1/8"	--	--	--	22"	3"	
		> 10° to 20°	8"	4 3/4"	2 7/8"	3 1/8"	10"	2 1/8"	--	--	--	22"	3"	
		> 20° to 30°	8 3/4"	5 1/4"	2 3/4"	3 1/4"	10 3/4"	2 1/8"	--	--	--	23"	3"	
		> 30° to 40°	9 3/4"	5 3/4"	2 5/8"	3 3/8"	11 3/4"	2 1/8"	--	--	--	23"	3"	
		> 40° to 50°	11 1/4"	6 1/2"	2 1/2"	3 1/2"	13 1/4"	2 1/8"	--	--	--	23"	3"	
B	280' to 440'	0° to 5°	9"	6"	3"	3"	12"	3 1/8"	--	--	--	23"	4"	
		> 5° to 10°	9 1/4"	6 1/4"	2 7/8"	3 1/8"	12 1/4"	3 1/8"	--	--	--	24"	4"	
		> 10° to 20°	10"	6 3/4"	2 7/8"	3 1/8"	13"	3 1/8"	--	--	--	24"	4"	
		> 20° to 30°	10 3/4"	7 1/4"	2 3/4"	3 1/4"	13 3/4"	3 1/8"	--	--	--	25"	4"	
		> 30° to 40°	12"	8"	2 3/4"	3 1/4"	15"	3 1/8"	--	--	--	25"	4"	
		> 40° to 50°	13 1/2"	8 3/4"	2 5/8"	3 3/8"	16 1/2"	3 1/8"	--	--	--	25"	4"	
C	440' to 600'	0° to 10°	11 1/4"	8 1/4"	3"	3"	15 1/4"	4 1/8"	9"	4"	1 1/2"	26"	5"	
		> 10° to 20°	12"	8 3/4"	2 7/8"	3 1/8"	16"	4 1/8"	10"	4"	1 1/2"	26"	5"	
		> 20° to 30°	12 3/4"	9 1/4"	2 7/8"	3 1/8"	16 3/4"	4 1/8"	11"	11"	4"	1 1/2"	26"	5"
		> 30° to 40°	14"	10"	2 3/4"	3 1/4"	18"	4 1/8"	11"	11"	4"	1 1/2"	26"	5"
		> 40° to 50°	15 1/2"	10 3/4"	2 3/4"	3 1/4"	19 1/2"	4 1/8"	12"	12"	4"	1 1/2"	26"	5"
		0° to 10°	13 1/4"	10 1/4"	3"	3"	18 1/4"	5 1/8"	11"	11"	5"	2"	30"	6"
D	600' to 760'	> 10° to 20°	14"	10 3/4"	2 7/8"	3 1/8"	19"	5 1/8"	12"	5"	2"	30"	6"	
		> 20° to 30°	14 3/4"	11 1/4"	2 7/8"	3 1/8"	19 3/4"	5 1/8"	13"	5"	2"	30"	6"	
		> 30° to 40°	16"	12"	2 7/8"	3 1/8"	21"	5 1/8"	13"	13"	5"	2"	30"	6"
		> 40° to 50°	17 3/4"	13"	2 3/4"	3 1/4"	22 3/4"	5 1/8"	15"	15"	5"	2"	30"	6"
		0° to 10°	15 1/4"	12 1/4"	3"	3"	21 1/4"	6 1/8"	13"	13"	6"	2 1/2"	36"	7"
		> 10° to 20°	16"	12 3/4"	2 7/8"	3 1/8"	22"	6 1/8"	14"	14"	6"	2 1/2"	36"	7"
E	760' to 920'	> 20° to 30°	16 3/4"	13 1/4"	2 7/8"	3 1/8"	22 3/4"	6 1/8"	15"	6"	2 1/2"	36"	7"	
		> 30° to 40°	18"	14"	2 7/8"	3 1/8"	24"	6 1/8"	15"	6"	2 1/2"	36"	7"	
		> 40° to 50°	19 3/4"	15"	2 3/4"	3 1/4"	25 3/4"	6 1/8"	17"	17"	6"	2 1/2"	36"	7"

NOTES:

1. Each "Expansion Device - Finger Joint" consists of one backwall element and one superstructure element (or two superstructure elements over piers) with expansion dams as required.
2. Refer to Design Drawings for dimensions, slopes, skew and all other information necessary to fabricate and install each Expansion Device.
3. The Expansion Device shall be fabricated to be installed normal to grade.
4. Anchor studs shall be installed using automatically timed stud welding equipment.
5. The Expansion Device shall be installed with a joint opening of "J" at 45 °F. The joint opening shall be adjusted for temperature in the field at the time of installation using the following formula:  
$$0.00008 \times "D" \times "\Delta T" = \text{Adjustment (in inches)}$$

"D" is the distance in feet between the backwall and the nearest fixed bearings (for joints at abutments) or between the fixed bearings at either side of the expansion joint (for joints at piers). " $\Delta T$ " is the difference between the temperature of the structure and 45 °F.

A structure temperature above 45 °F will result in a smaller joint opening.
6. Welding to reinforcing steel will be allowed in the top of the abutment backwall above the block - out joint.
7. After the Expansion Device is in final position, weld the bar and angle of the adjustment devices together with a 1/4-in. fillet weld.
8. The slab and backwall concrete shall be in place before the Expansion Device is fixed in position. No allowance for movement due to dead load deflection is necessary.
9. The concrete in the block - out may be placed with the curb / sidewalk concrete. An approved epoxy bonding agent shall be applied to all vertical surfaces of the block - out before making the final concrete placement.
10. If there is a conflict between these Standard Details and the Design Drawings, the requirements of the Design Drawings shall be followed.

MATERIALS:

All shapes and plates ..... AASHTO M 270M/M 270, Grade 36

EXPANSION DEVICE - FINGER JOINT  
52(12)

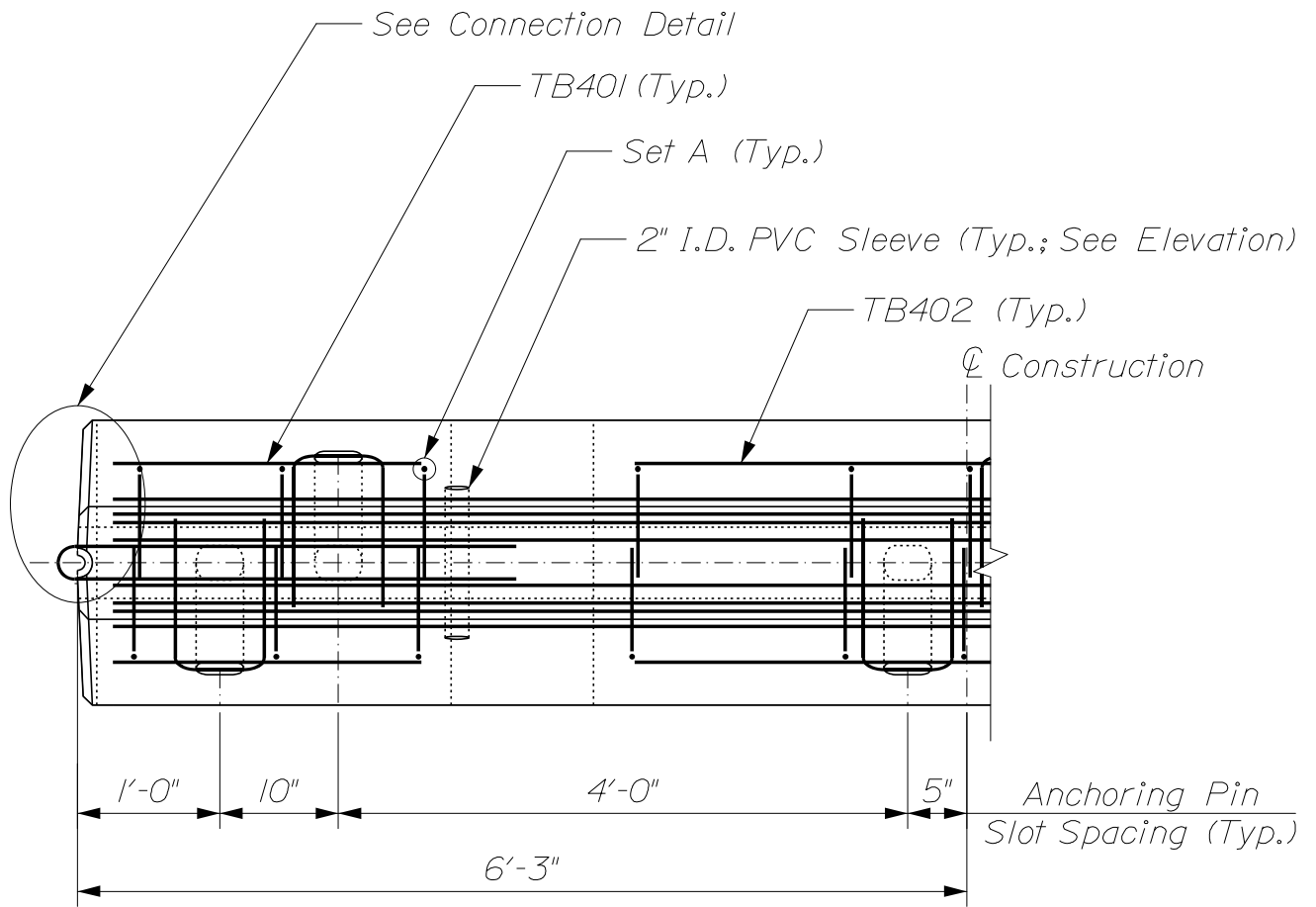

TB451, As Shown in Section B-B (1 Per Anchoring Pin Slot, Center Around Slot; Typ.)

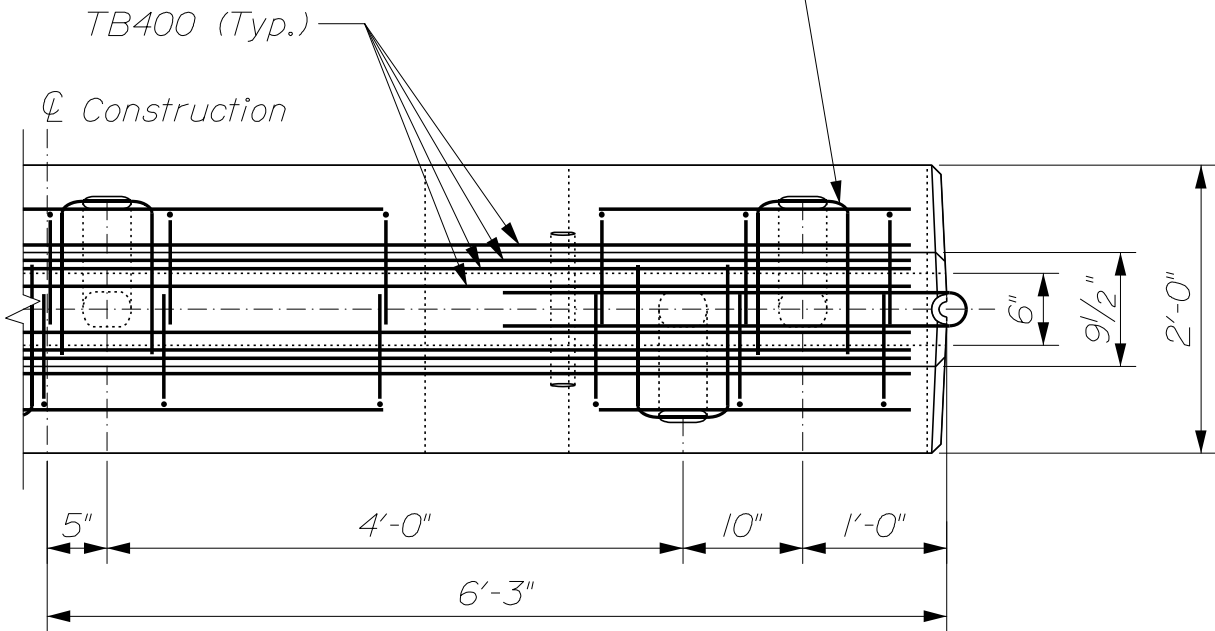

~ PLAN ~

PORTABLE CONCRETE BARRIER  
526(01)

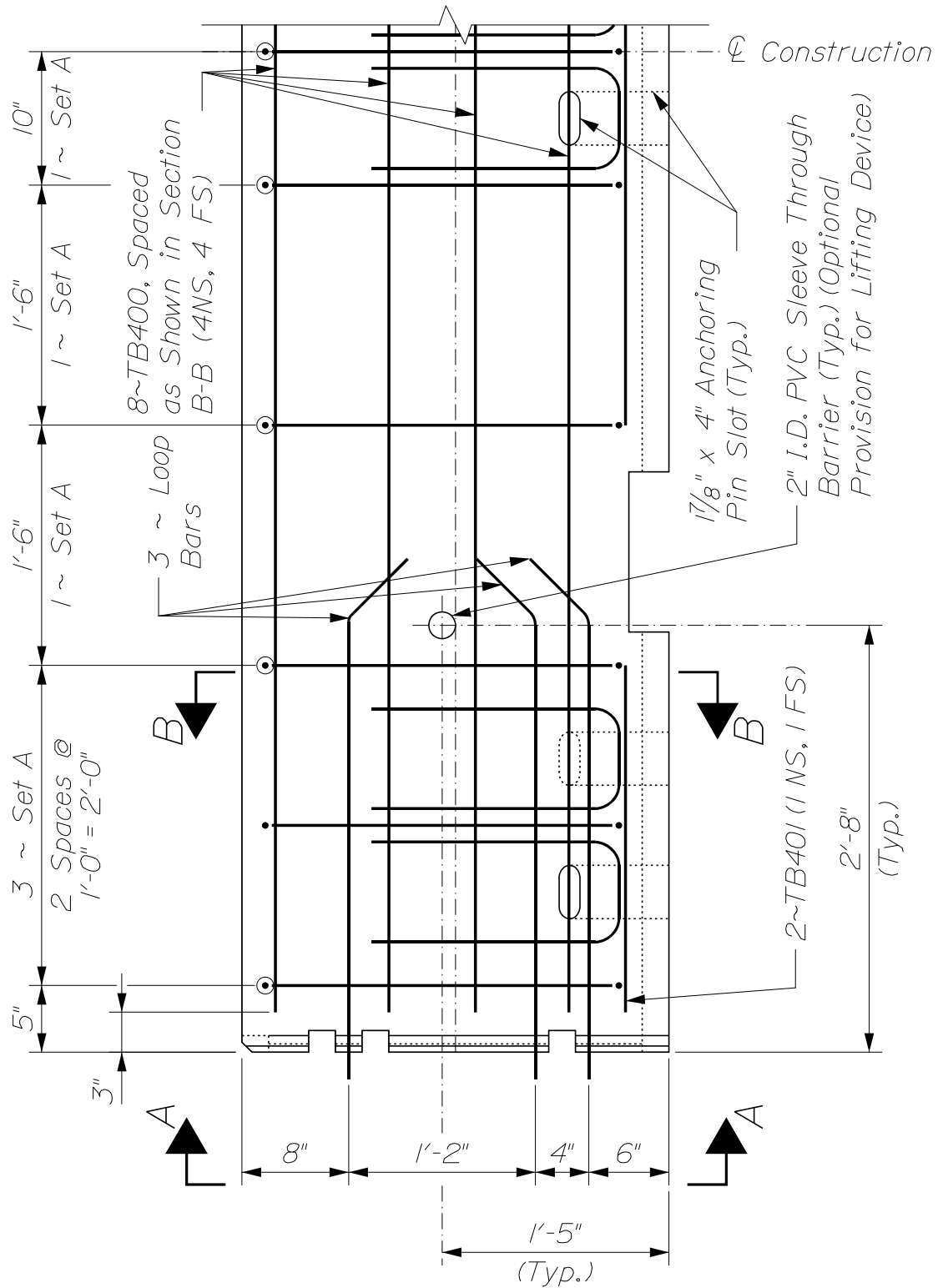

~ ELEVATION (1 of 2) ~

PORTABLE CONCRETE BARRIER  
526(01A)

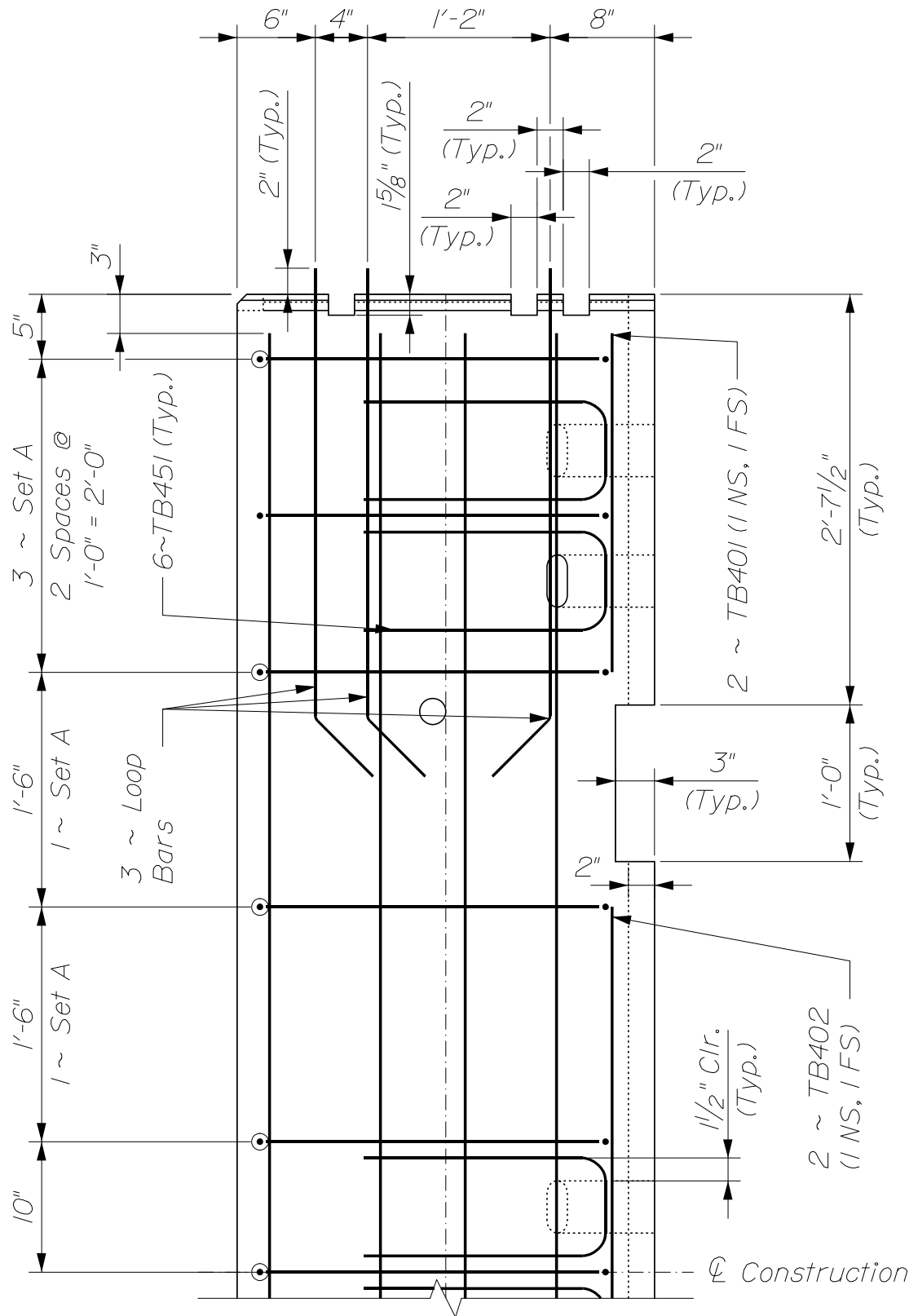

~ ELEVATION (2 of 2) ~

PORTABLE CONCRETE BARRIER  
526(01B)

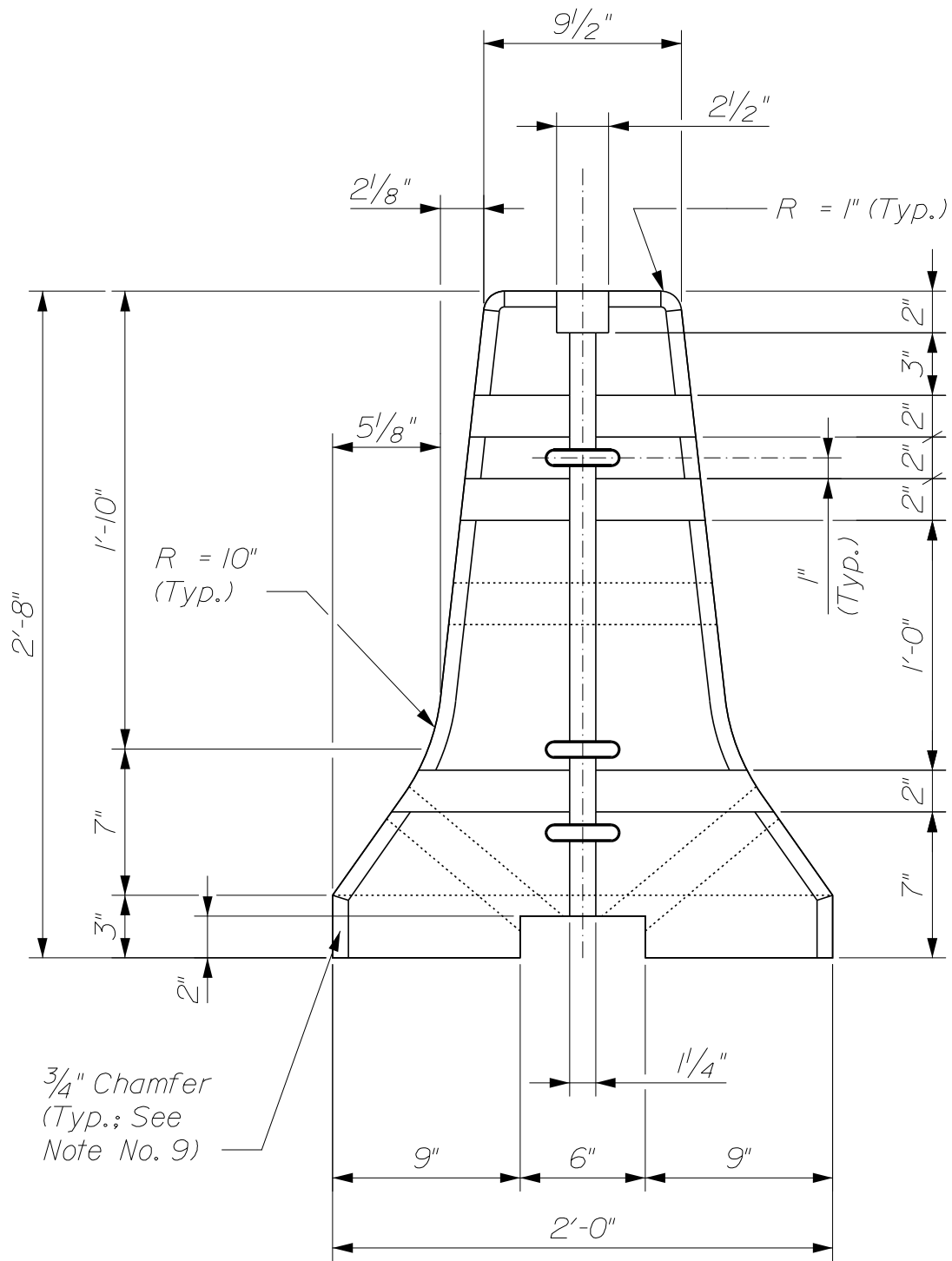

~ SECTION A-A ~

PORTABLE CONCRETE BARRIER  
526(02)

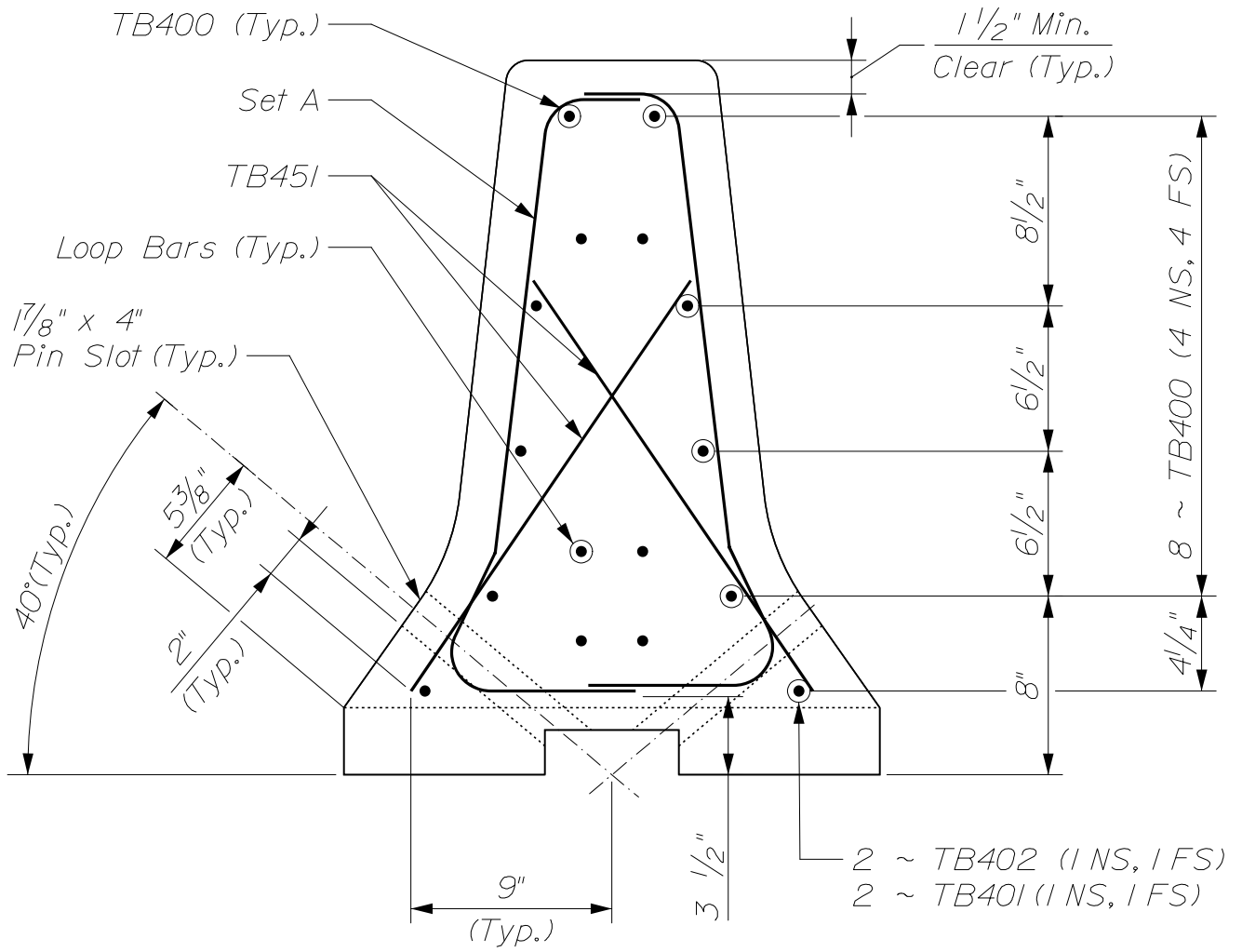

~ SECTION B-B ~

PORTABLE CONCRETE BARRIER  
526(02A)

STRAIGHT BARS			
MARK	QTY.	LENGTH	NOTES
TB400	8	12'-0"	Grade 60
TB401	4	2'-2"	Grade 60
TB402	2	4'-8"	Grade 60
BENT BARS			
MARK	QTY.	LENGTH	NOTES
TB450	22	3'-4"	Grade 60
TB451	6	4'-5"	Grade 60

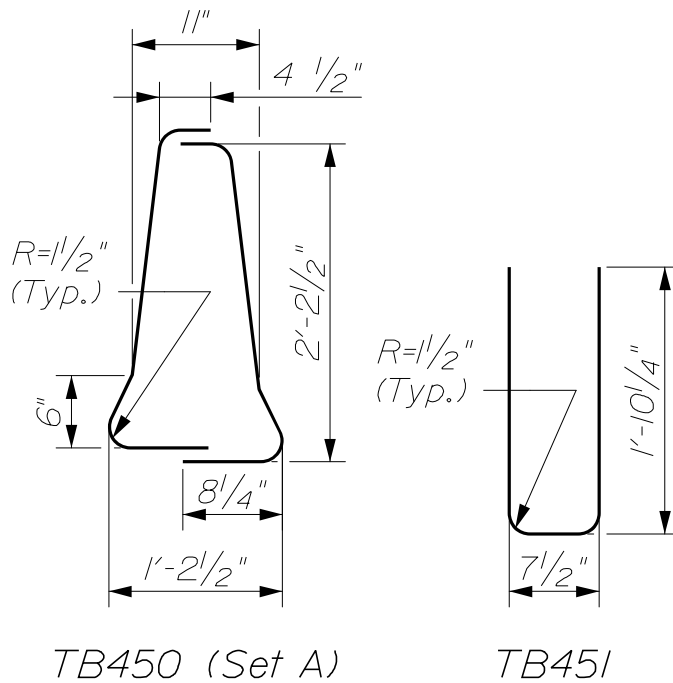

REINFORCEMENT BAR SCHEDULE

PORTABLE CONCRETE BARRIER  
526(03)

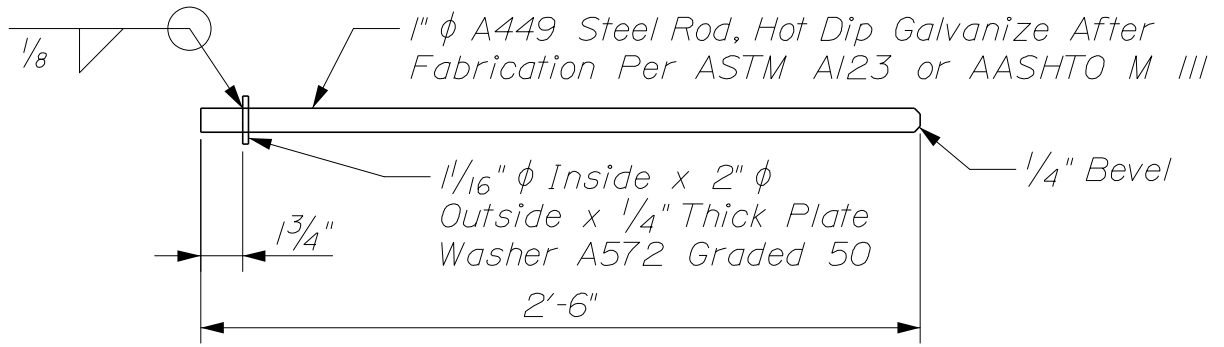

~ LINKING PIN DETAIL ~

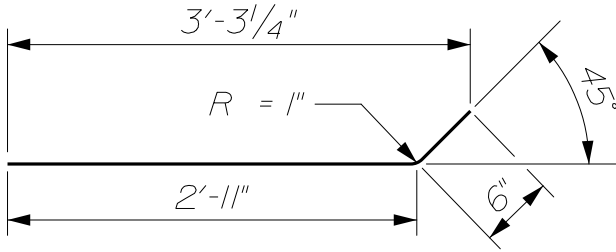

ELEVATION

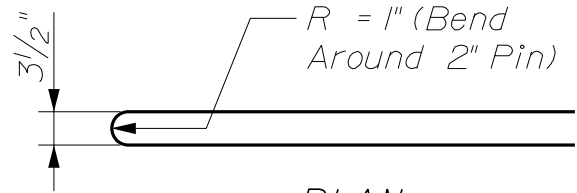

PLAN

3/4"  $\phi$  A36 Loop Bar

(Hot Dip Galvanized After Fabrication Per ASTM A123 or AASHTO M III)

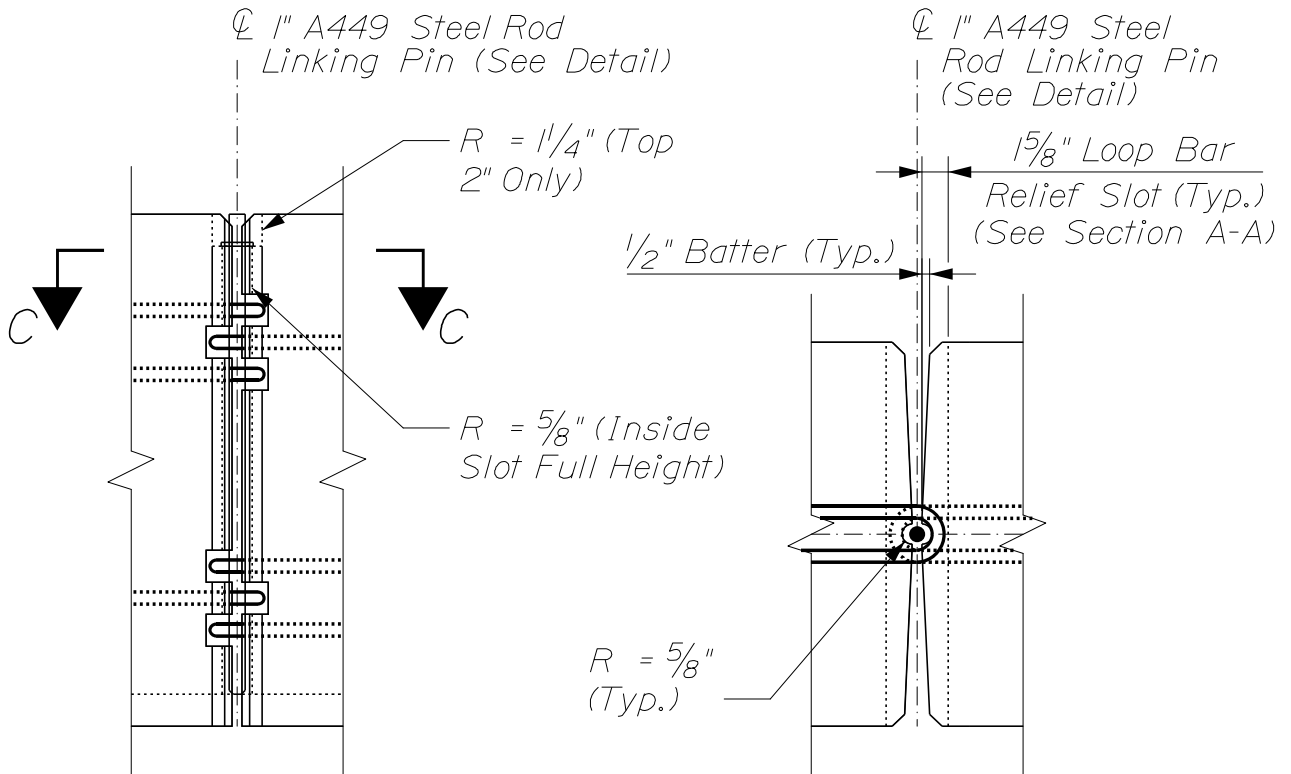

~ ELEVATION ~

~ SECTION C-C ~

~ CONNECTION DETAIL ~

PORTABLE CONCRETE BARRIER

526(04)

## GENERAL NOTES:

1. Alternate barrier designs may be selected from the appropriate MaineDOT Qualified Products List.
2. The portable concrete barrier details as shown on these sheets are in compliance with the Manual for Assessing Safety Hardware (MASH-16). See the Roadside Safety Research Program Pooled Fund Study No. TPF-5 (114), May 2017.
3. Barrier weighs approximately 2.84 tons/unit.
4. Freestanding barrier has been TL-3 crash tested with a 5.28 foot dynamic deflection.
5. Barrier concrete shall have a minimum 28 day compressive strength of 5,000 psi.
6. Reinforcing steel shall be AASHTO M31 (ASTM-A615) Grade 60.
7. Each barrier shall include one linking pin.
8. Lifting options shown are advisory only. The contractor shall provide adequate lifting points on each barrier.
9. Form a  $\frac{3}{4}$ -inch chamfer or radius on all exposed edges.
10. Barrier shall be supplemented with standard delineators, channelizing devices, or pavement markings when it serves to channelize traffic.

## REINFORCEMENT BAR NOTES:

1. The first two digits following the letter(s) of the mark indicate the size of the bar:

Mark "TB450" = bar size #4

2. All dimensions are out-to-out of bar.

PORTABLE CONCRETE BARRIER  
526(04A)

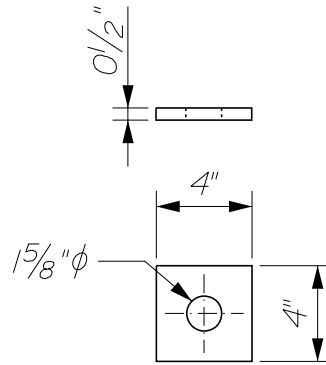
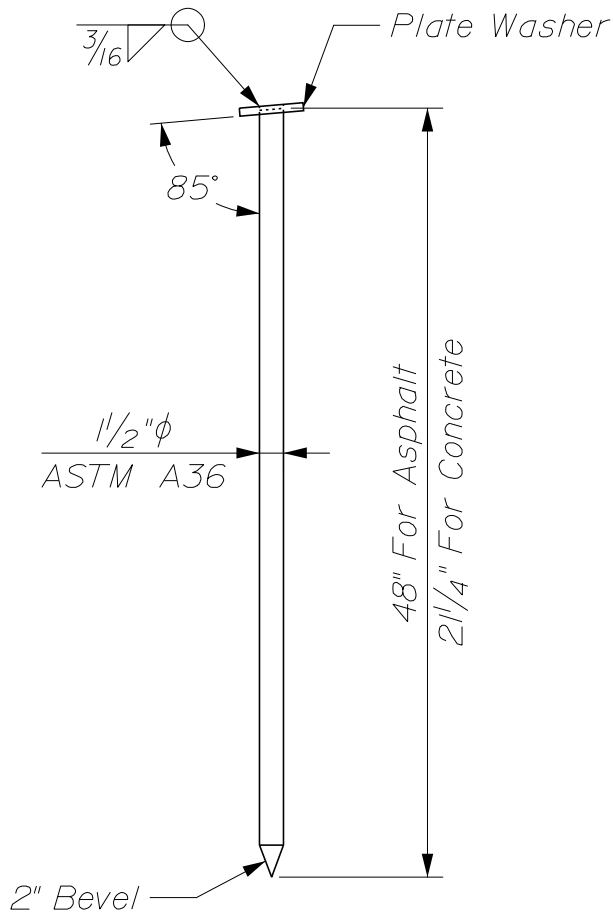

~ PLATE WASHER DETAIL ~

~ ANCHOR PIN DETAIL ~

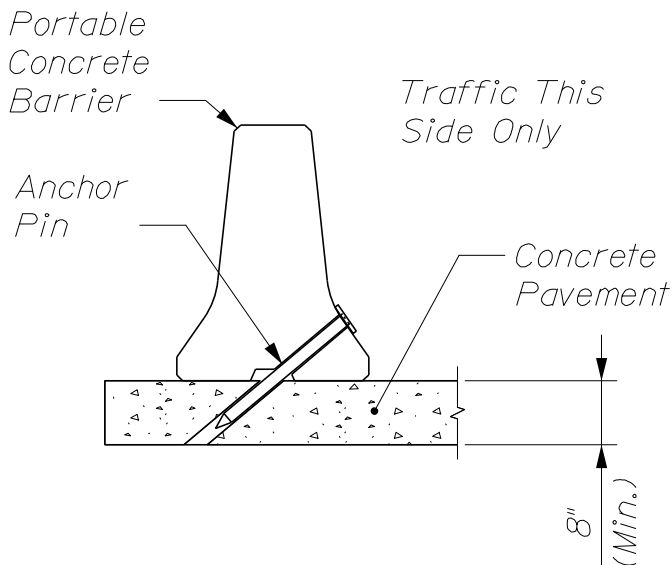

~ BARRIER ANCHOR PINNED TO CONCRETE PAVEMENT ~

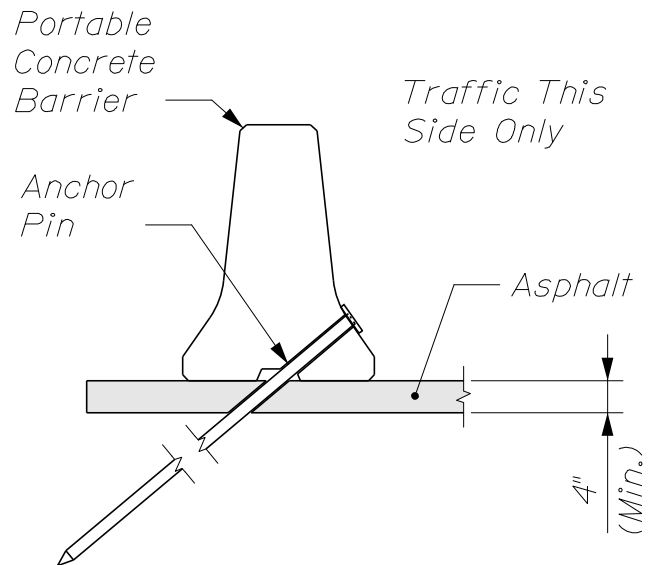

~ BARRIER ANCHOR PINNED TO ASPHALT PAVEMENT ~

PORTABLE CONCRETE BARRIER  
526(04B)

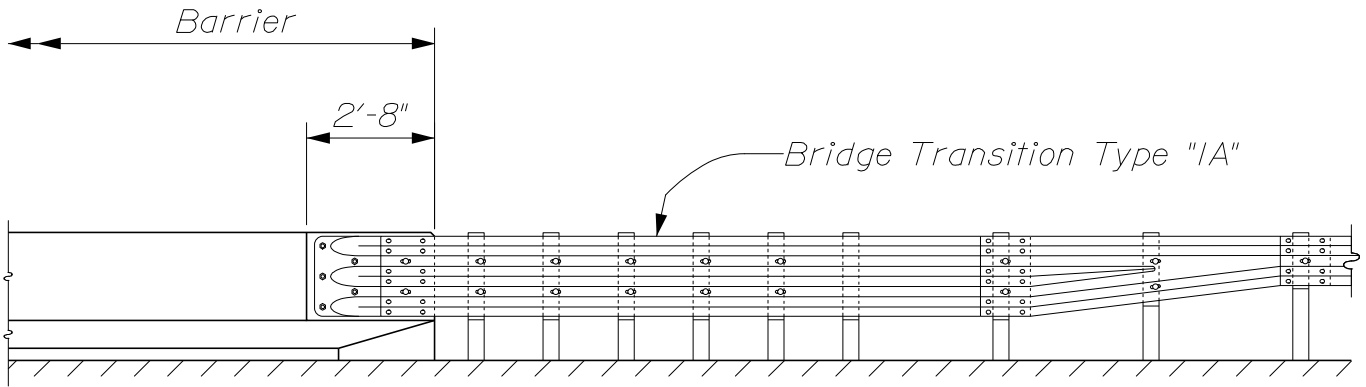

~ PERMANENT CONCRETE BARRIER TYPE IIIA ~

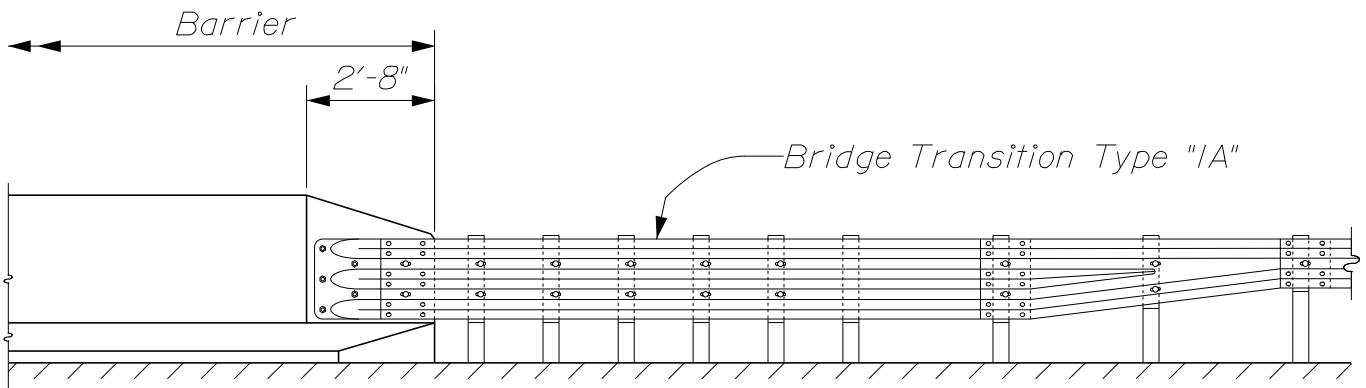

~ PERMANENT CONCRETE BARRIER TYPE IIIB ~

PERMANENT CONCRETE BARRIER  
526(05)

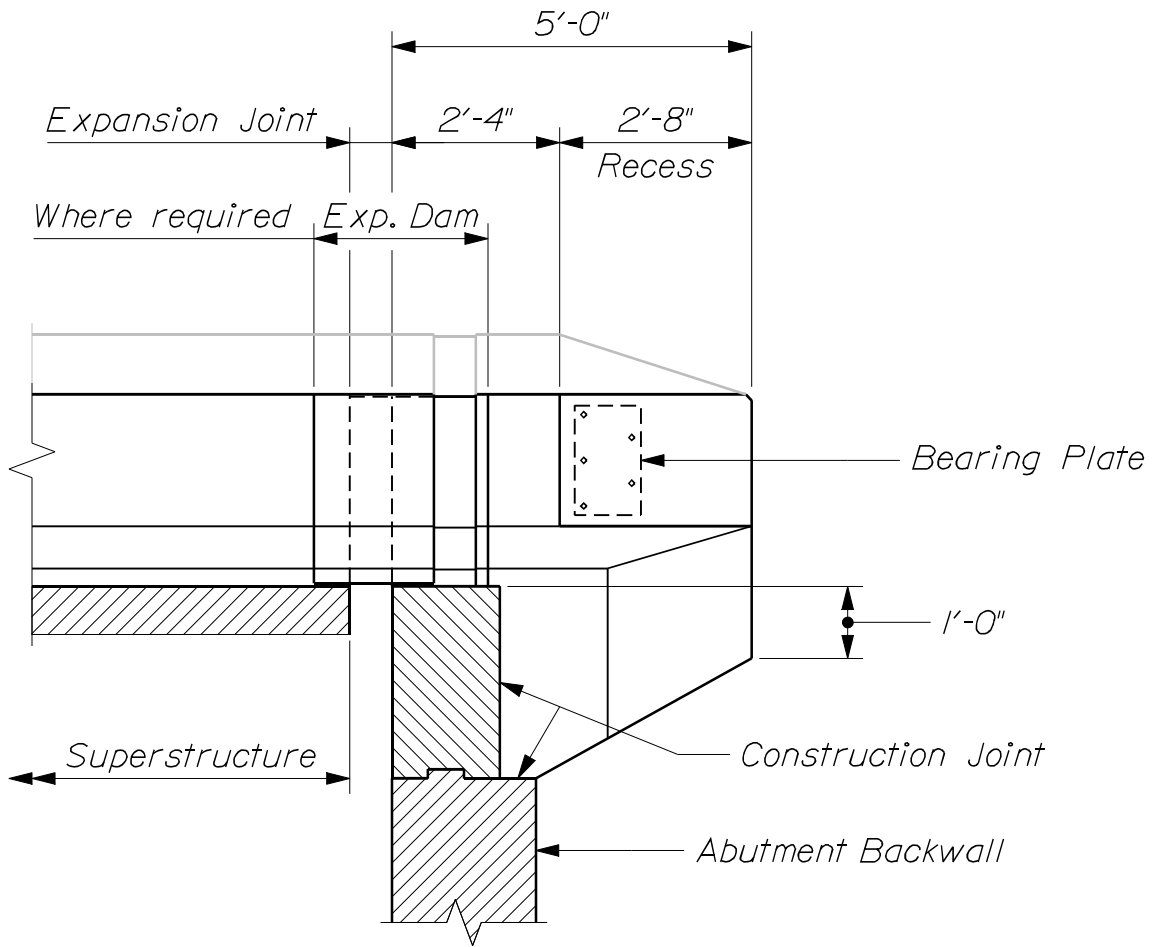

~ CANTILEVERED END AT EXPANSION JOINT ~

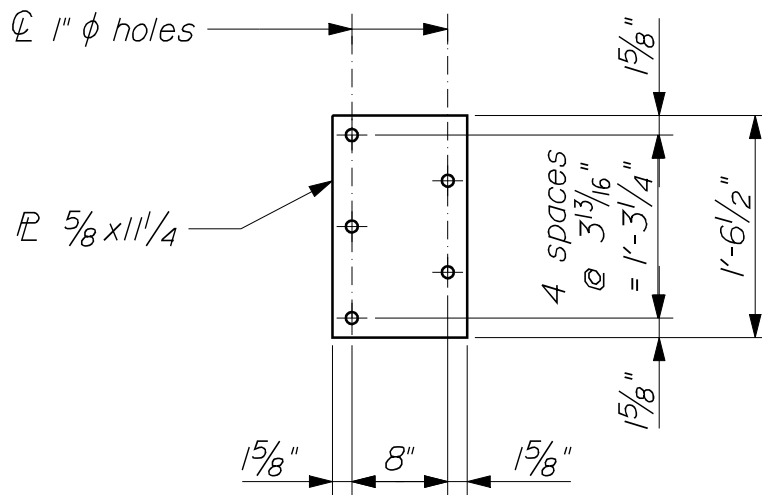

~ BEARING PLATE ~

PERMANENT CONCRETE BARRIER  
526(06)

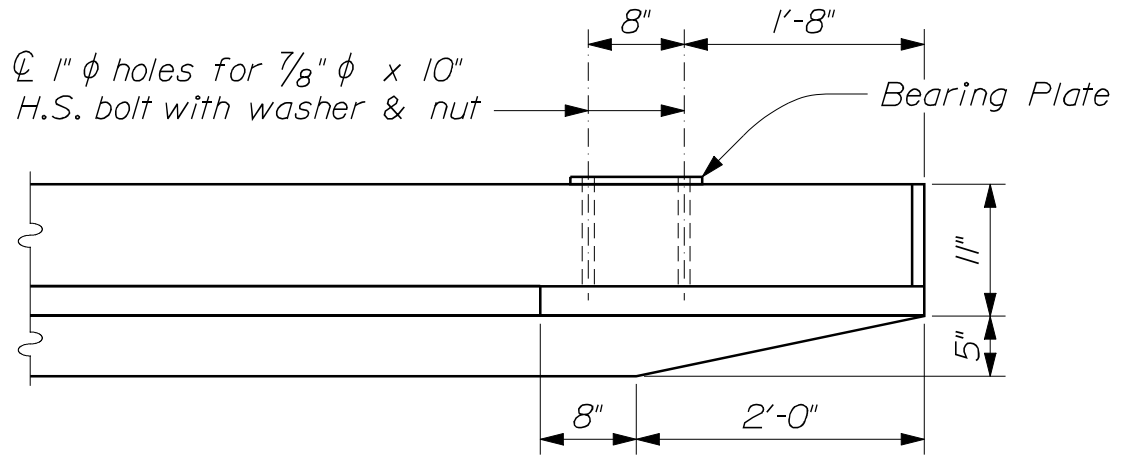

~ PLAN ~  
(Type IIIA)

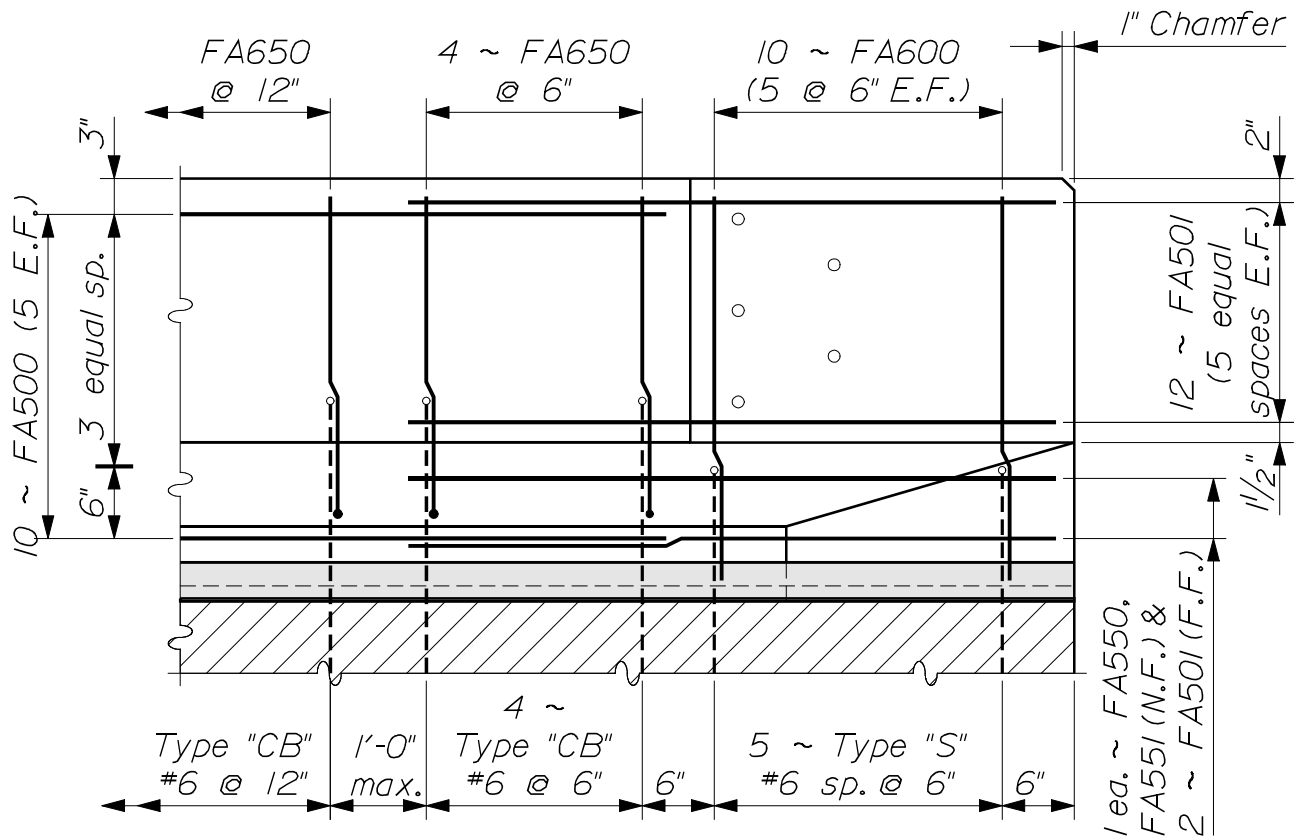

~ ELEVATION ~  
(Type IIIA)

PERMANENT CONCRETE BARRIER  
526(07)

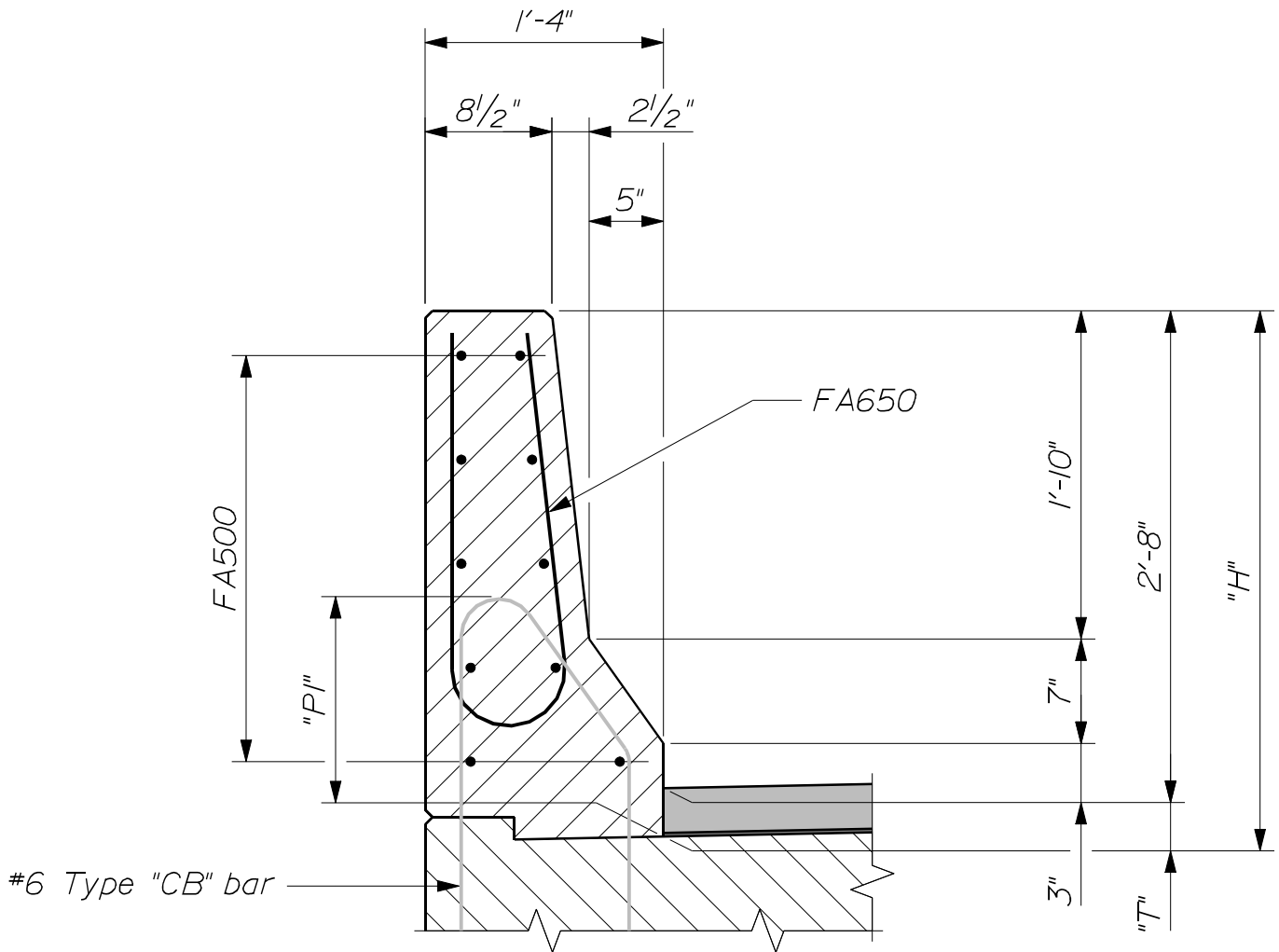

~ TYPICAL BARRIER SECTION ~  
(Type IIIA)

For Wearing Surface ("T") details, refer to Section 502 ~ Concrete Curb

TABLE OF DIMENSIONS - TYPE IIIA				
Wearing Surface Type	"P1"	"P2"	"T"	"H"
Bituminous	1'-4 1/4"	11 1/4"	3 1/4"	2'-11 1/4"
Unreinforced Concrete	1'-3"	10"	2"	2'-10"
Integral	1'-1"	8"	0"	2'-8"

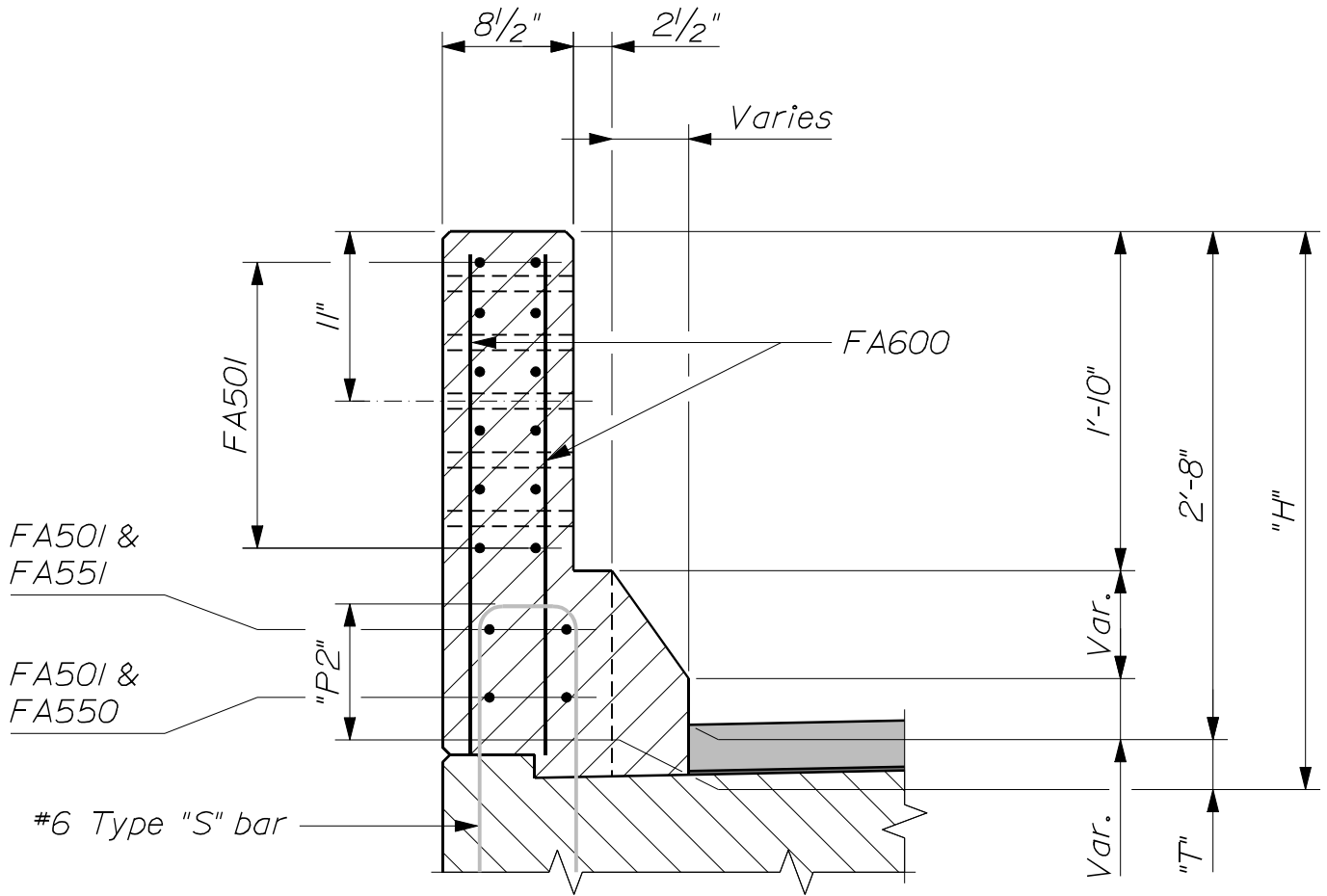

~ BARRIER RECESS SECTION ~  
(Type IIIA)

For Wearing Surface ("T") details, refer to Section 502 ~ Concrete Curb

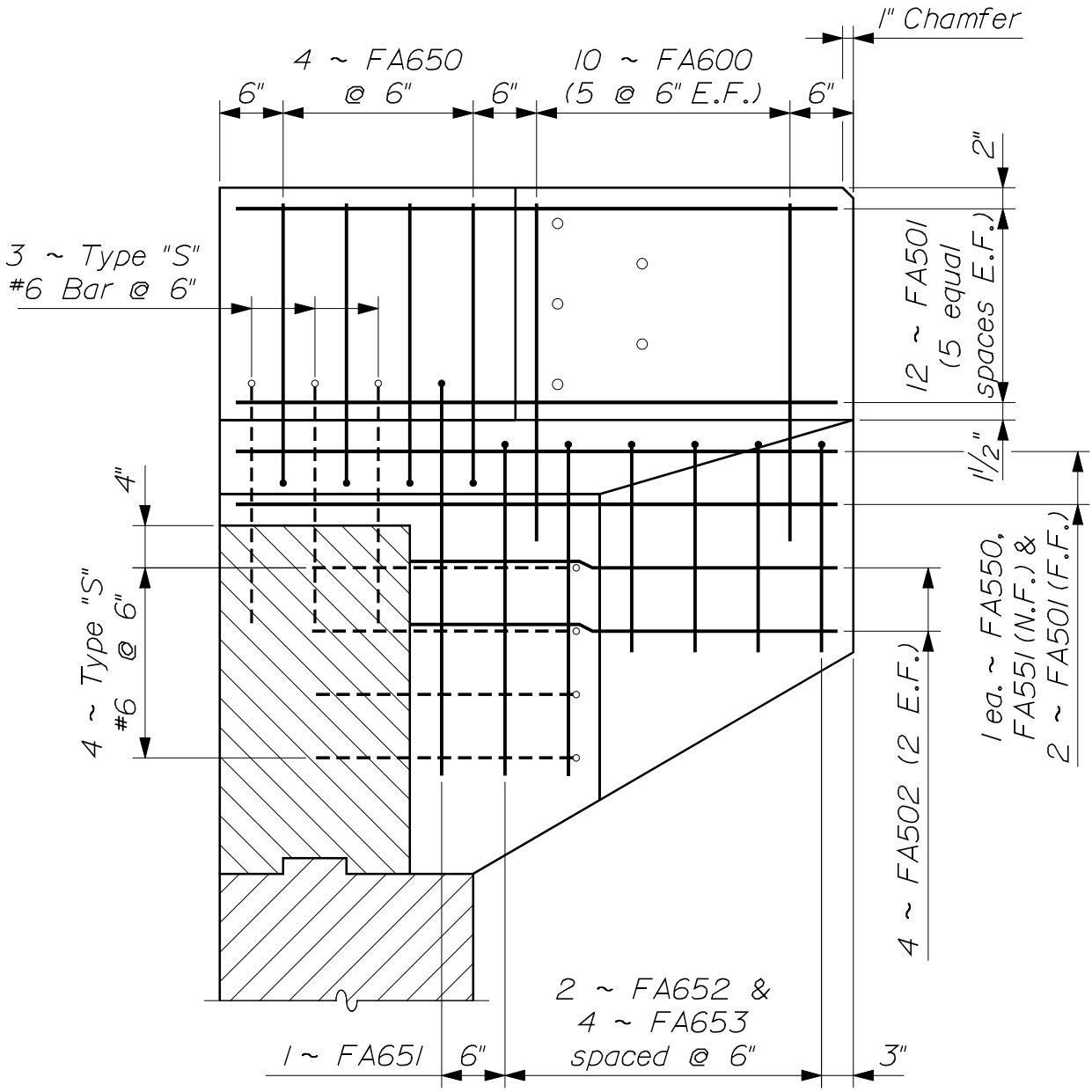

~ CANTILEVERED REINFORCING ELEVATION ~  
(Type IIIA)

PERMANENT CONCRETE BARRIER  
526(10)

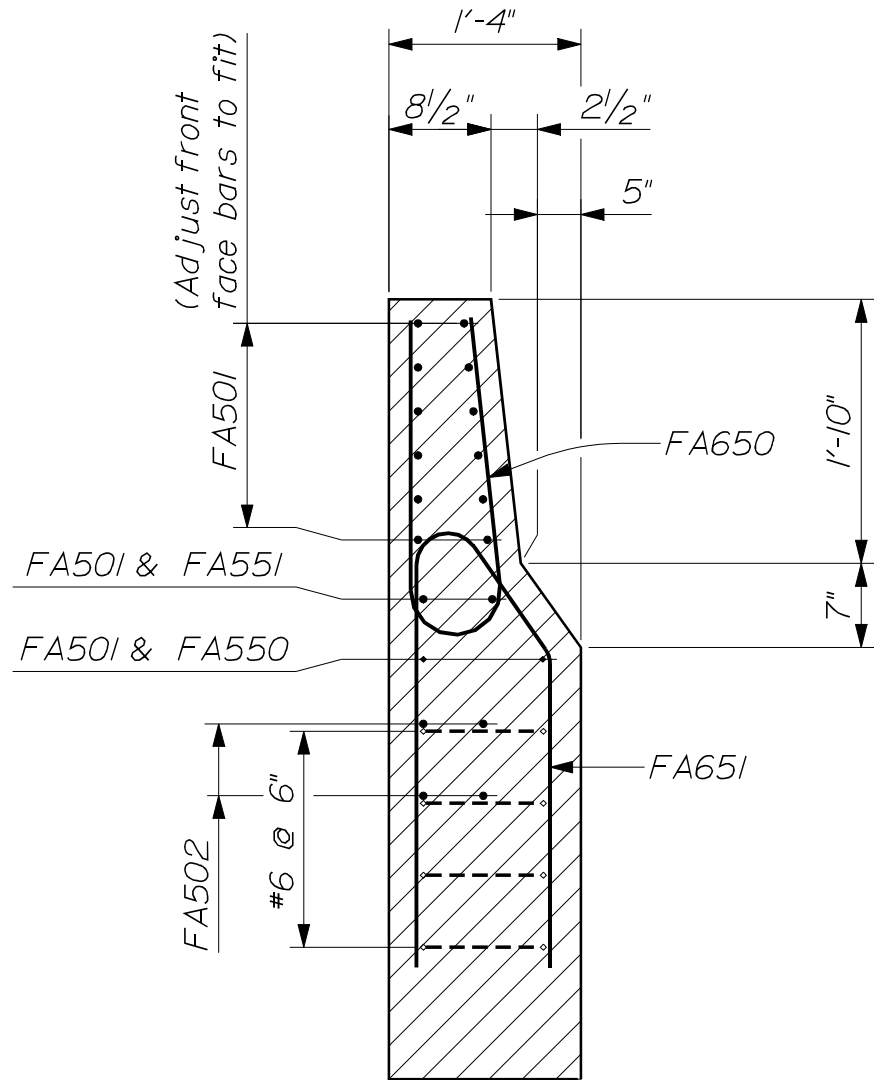

~ CANTILEVERED SECTION ~  
(Type IIIA)

PERMANENT CONCRETE BARRIER  
526(II)

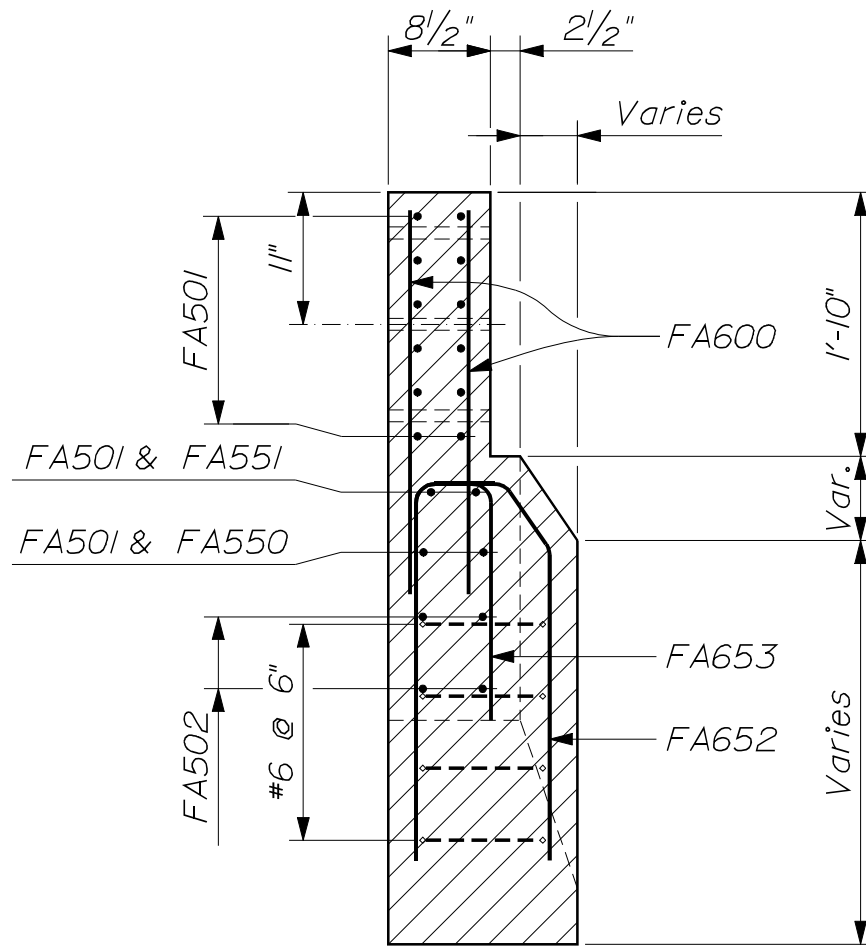

~ CANTILEVERED RECESS SECTION ~  
 (Type IIIA)

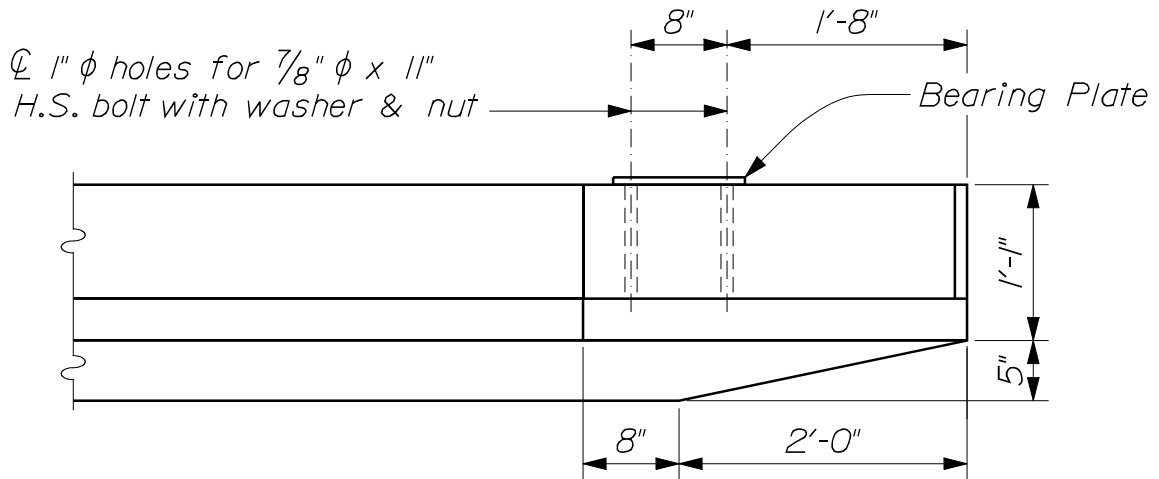

~ PLAN ~  
(Type IIIB)

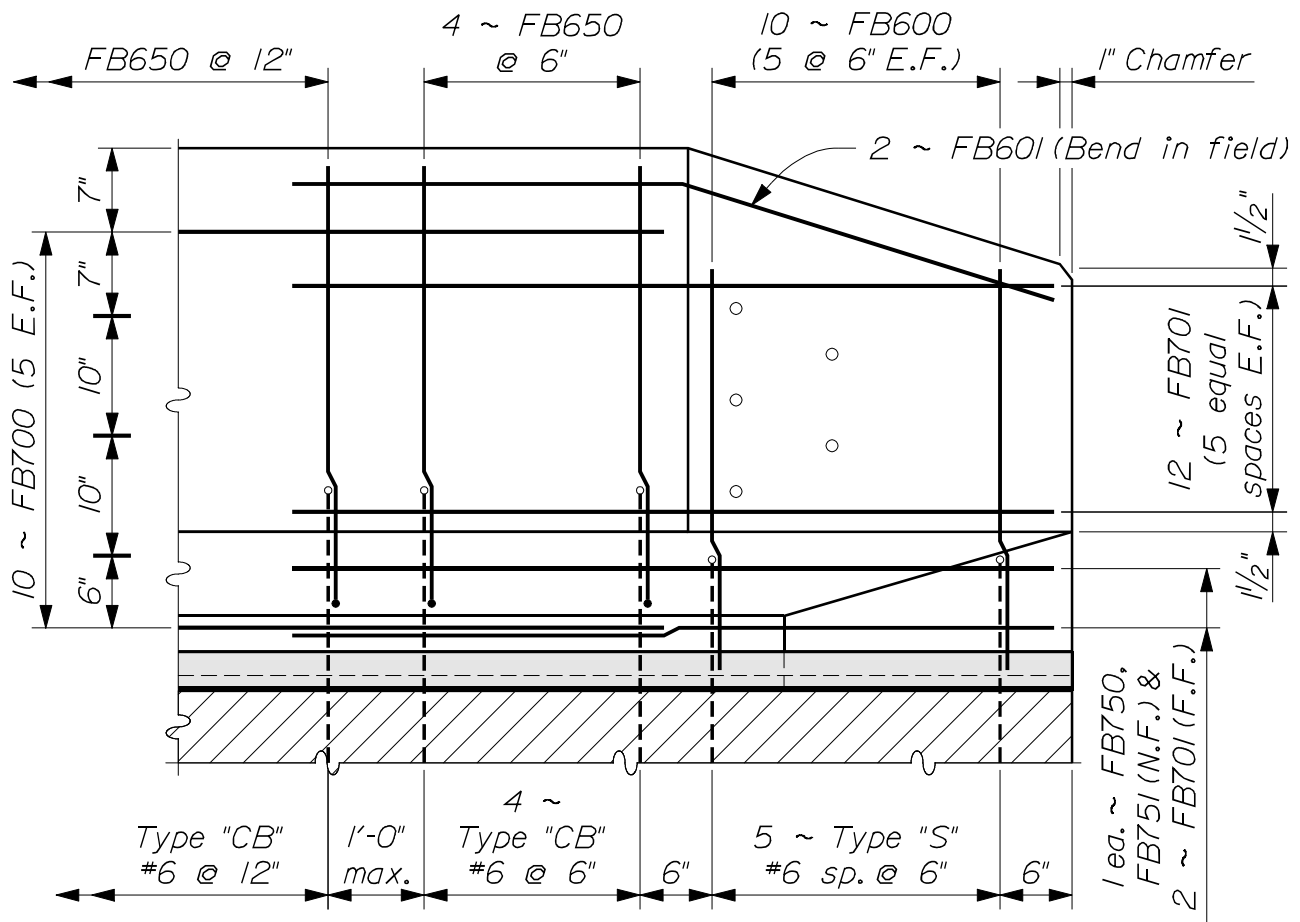

~ ELEVATION ~  
(Type IIIB)

PERMANENT CONCRETE BARRIER  
526(13)

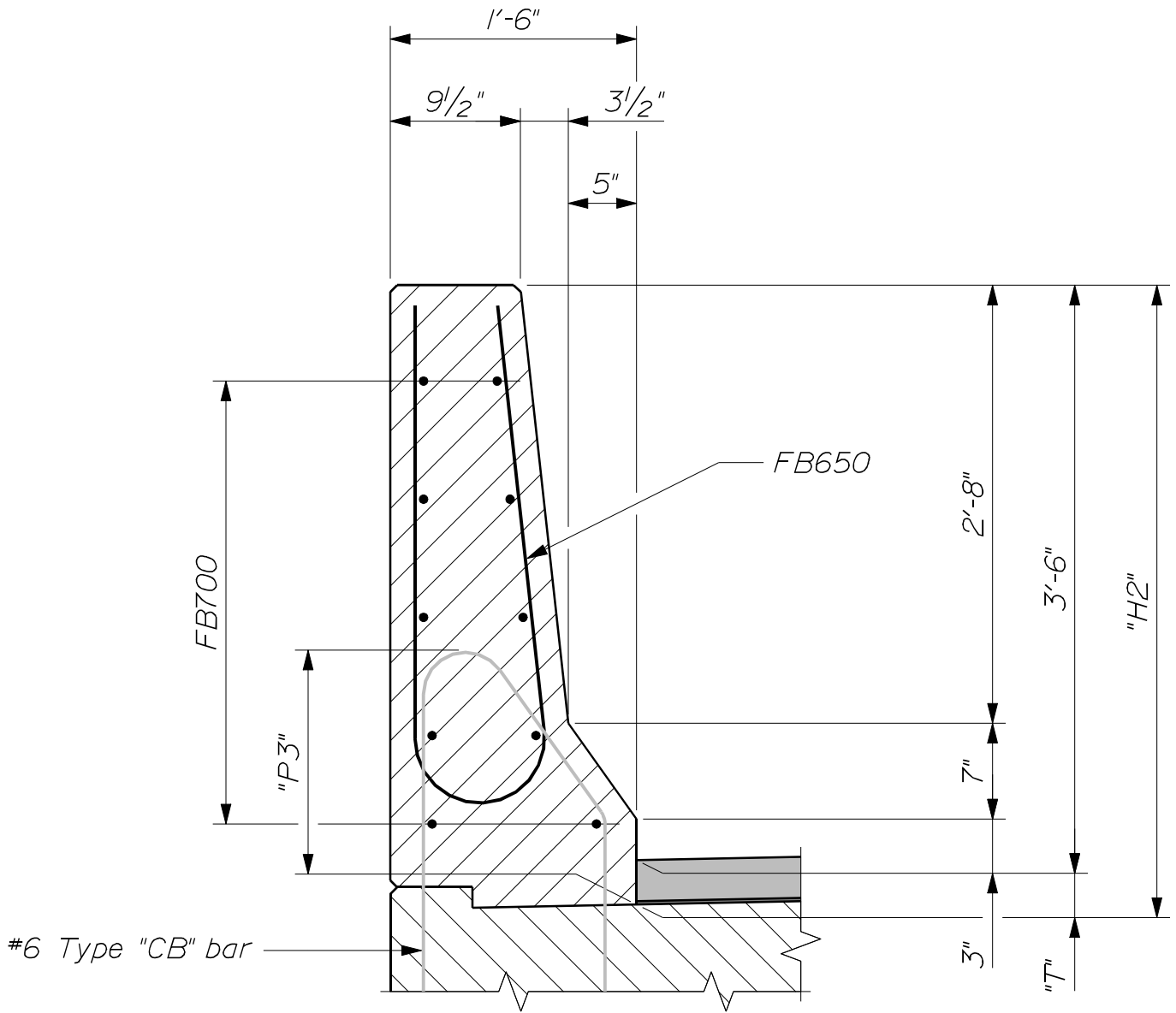

~ TYPICAL BARRIER SECTION ~  
(Type IIIB)

For Wearing Surface ("T") details, refer to Section 502 ~ Concrete Curb

TABLE OF DIMENSIONS - TYPE IIIB				
Wearing Surface Type	"P3"	"P4"	"T"	"H2"
Bituminous	1'-6 <sup>3</sup> / <sub>4</sub> "	11 <sup>1</sup> / <sub>4</sub> "	3 <sup>1</sup> / <sub>4</sub> "	3'-9 <sup>1</sup> / <sub>4</sub> "
Unreinforced Concrete	1'-5 <sup>1</sup> / <sub>2</sub> "	10"	2"	3'-8"
Integral	1'-3 <sup>1</sup> / <sub>2</sub> "	8"	0"	3'-6"

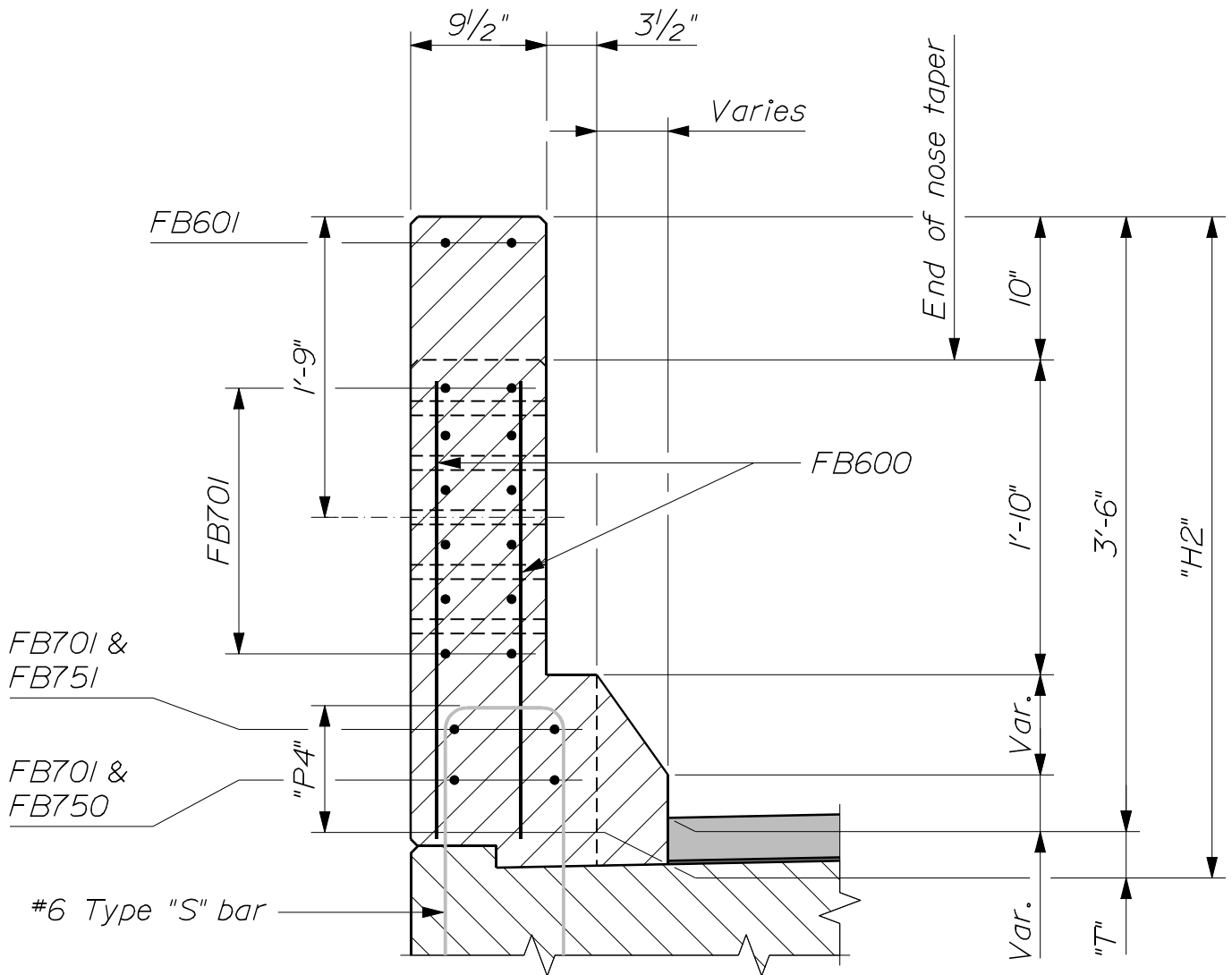

~ TYPICAL END SECTION ~  
 (Type IIIB)

For Wearing Surface ("T") details, refer to Section 502 ~ Concrete Curb

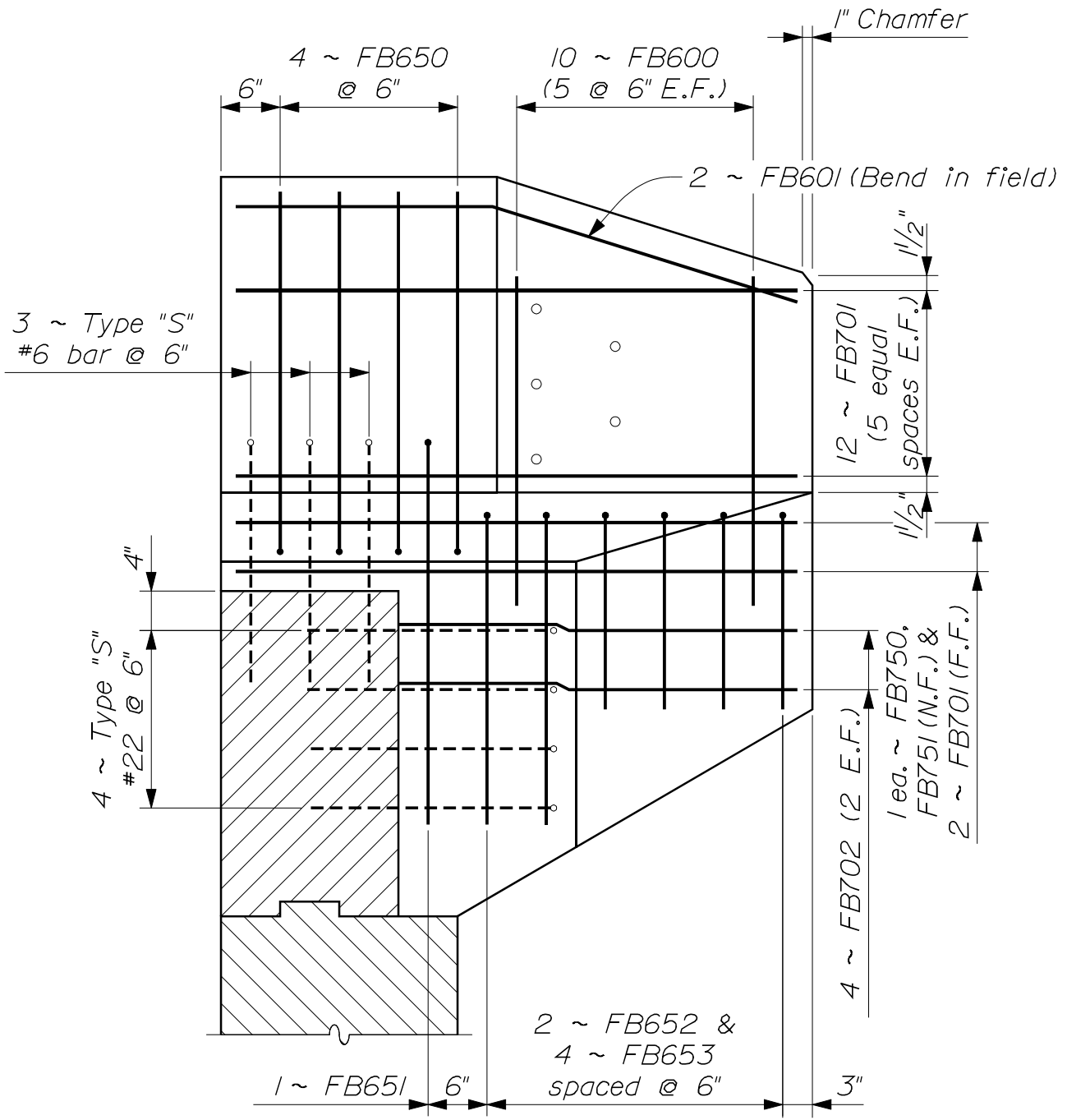

~ CANTILEVER REINFORCING ELEVATION ~  
(Type IIIB)

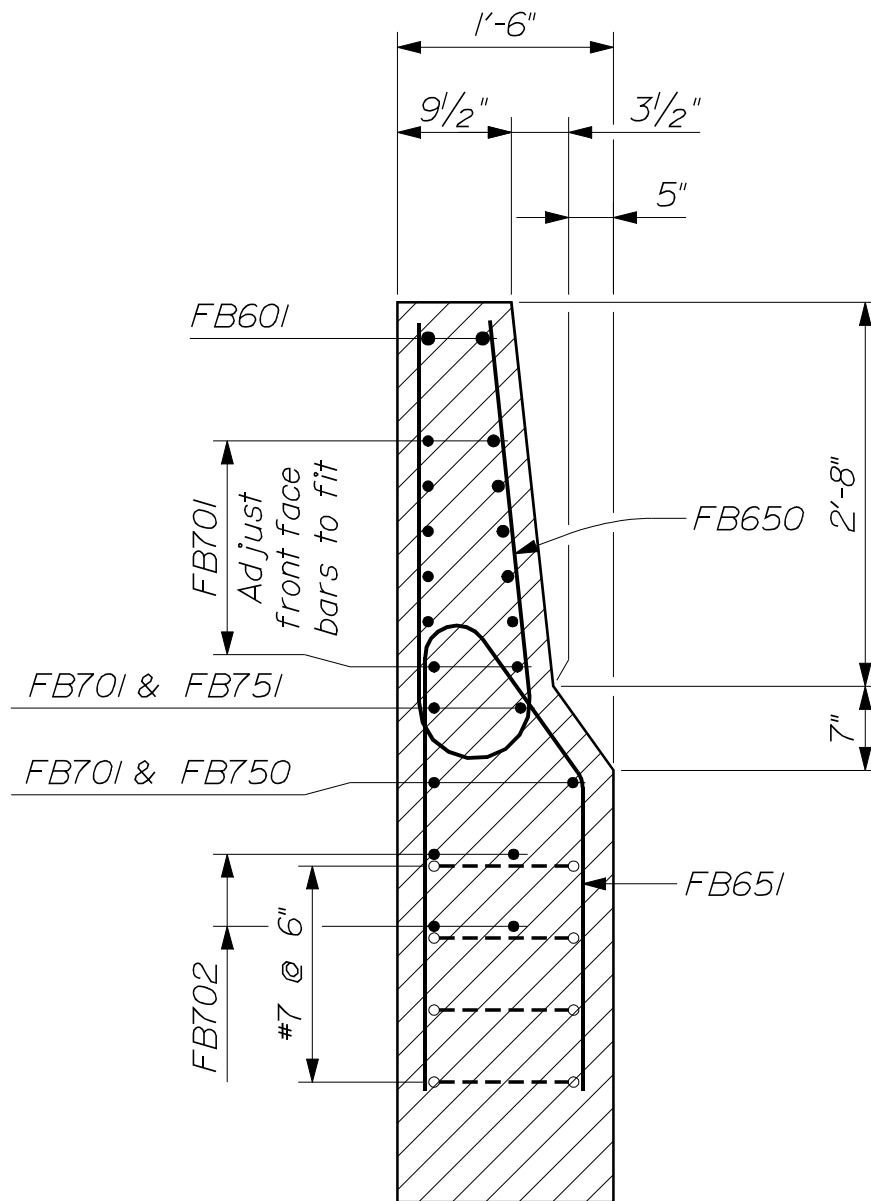

~ CANTILEVERED SECTION ~  
(Type IIIB)

PERMANENT CONCRETE BARRIER  
526(17)

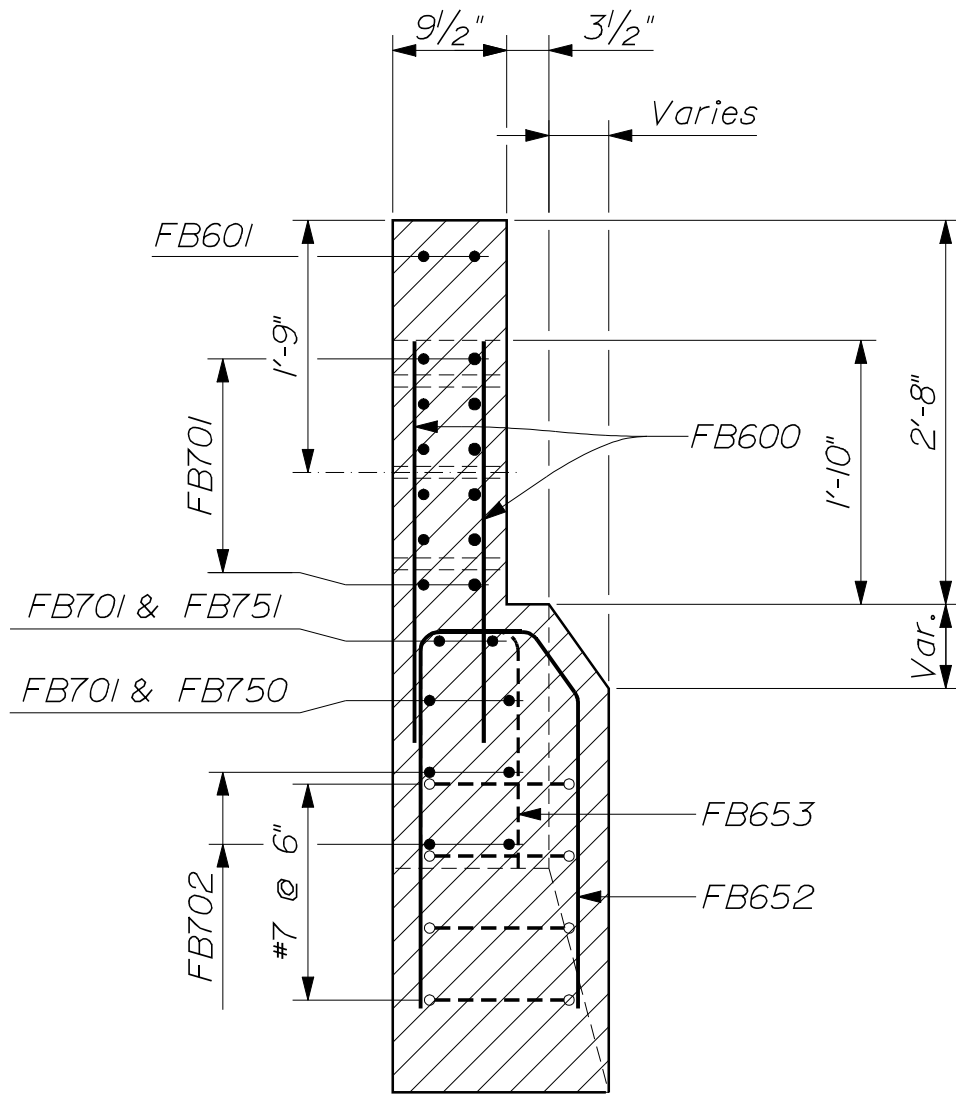

~ CANTILEVERED END SECTION ~  
 (Type IIIB)

## BARRIER TYPE IIIA REINFORCING STEEL

Mark	With Normal End		With Cantilevered End	
	Quantity	Length	Quantity	Length
FA500	As req'd	30'-0" max.	As req'd	30'-0" max.
FA501	14	4'-6"	14	4'-8"
FA550	1	4'-7"	1	4'-10"
FA551	1	4'-7"	1	4'-10"
FA600	10	2'-8"	10	2'-8"
FA650	As req'd	4'-10"	As req'd	4'-11"
FA651	--	--	1	6'-6"
FA652	--	--	2	6'-1"
FA653	--	--	4	3'-11"

(X) denotes cantilevered end dimension

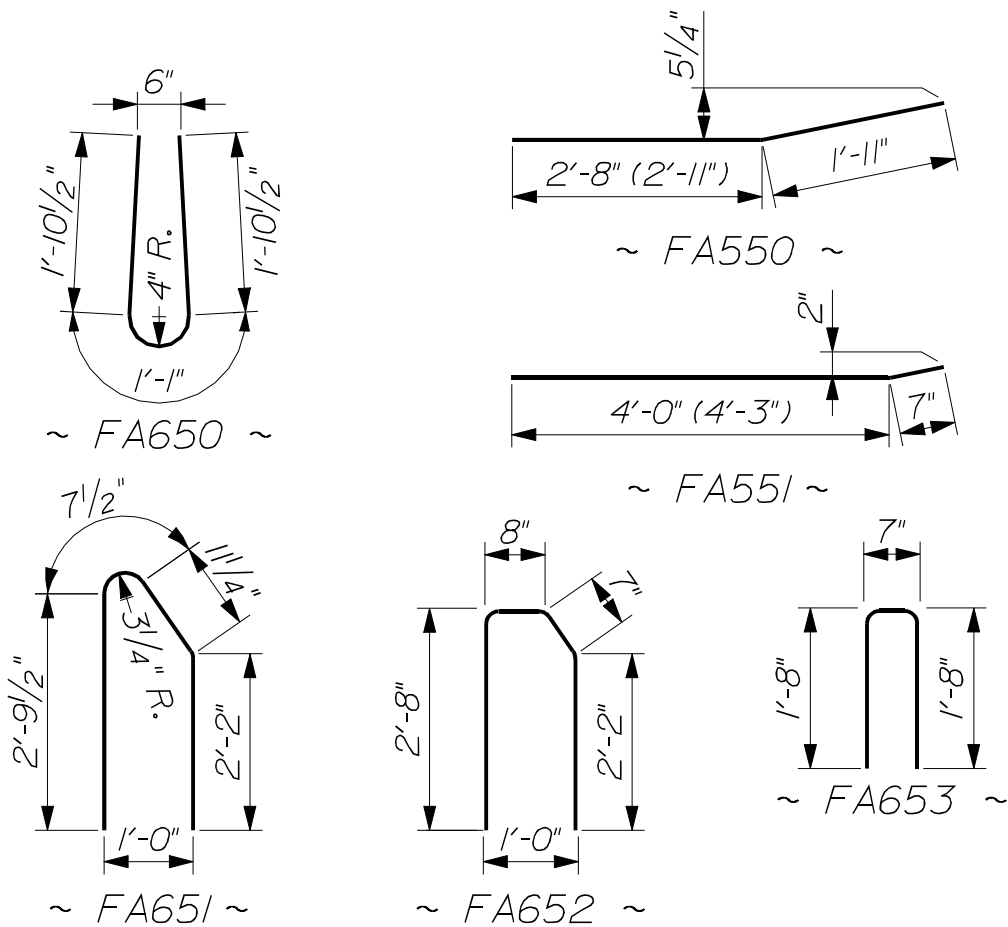

## BARRIER TYPE IIIB REINFORCING STEEL

Mark	With Normal End		With Cantilevered End	
	Quantity	Length	Quantity	Length
FB600	10	2'-10"	10	2'-10"
FB601	2	5'-5"	2	4'-9"
FB650	As req'd	6'-7"	As req'd	6'-7"
FB651	--	--	1	7'-0"
FB652	--	--	2	6'-3"
FB653	--	--	4	4'-1"
FB700	As req'd	60'-0" max.	As req'd	60'-0" max.
FB701	16	5'-4"	16	4'-8"
FB702	--	--	4	3'-4"
FB750	1	5'-5"	1	4'-10"
FB751	1	5'-5"	1	4'-10"

(X) denotes cantilevered end dimension

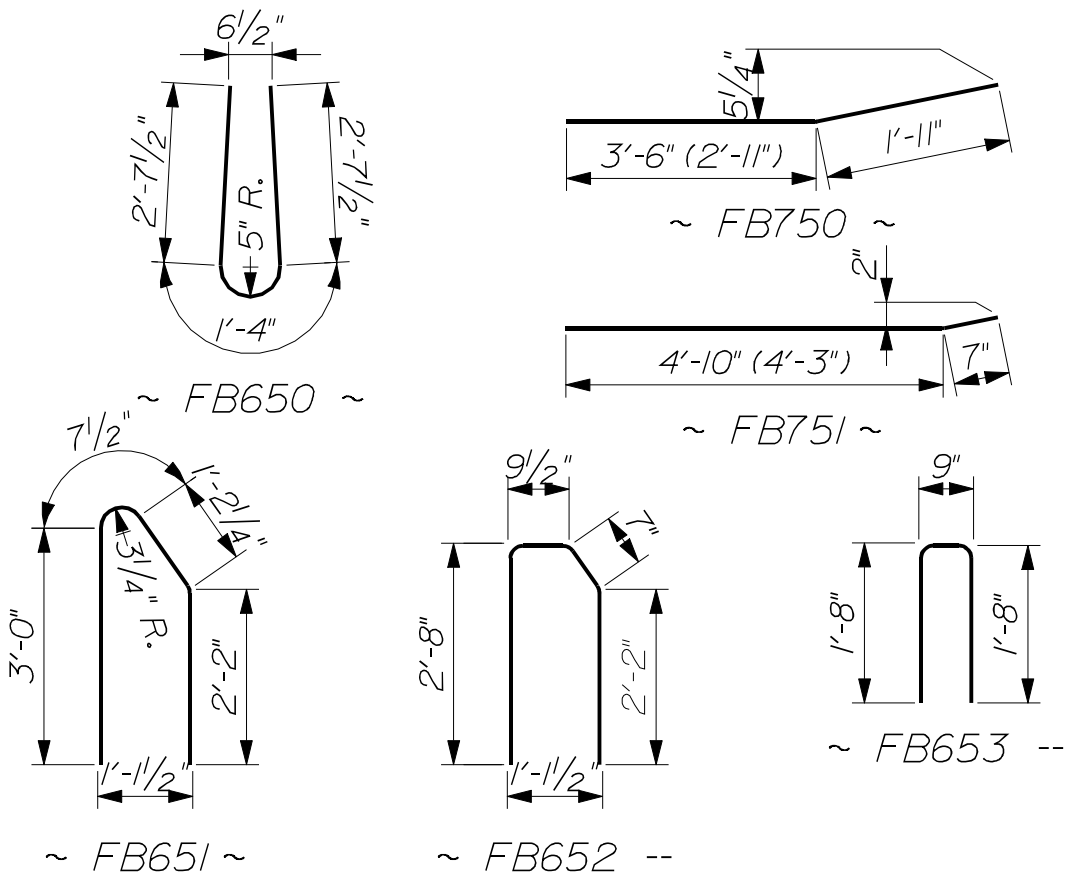

NOTES:

1. All work and materials shall conform to the provisions of Standard Specifications Section 526 - Concrete Barrier.
2. Reinforcing bar designations Type "S" and "CB" refer to type - bending diagrams as shown on the main Reinforcing Steel Schedule. These bars are detailed on the Design Drawings and are included for payment in the Reinforcing Steel pay items.
3. Reinforcing steel shall have a minimum concrete cover of  $1\frac{1}{2}$  inches, except that stirrups Type "S" and "CB" shall have a minimum concrete cover of 2 inches.
4. The first digit following the letters of the mark indicates the size of the reinforcing bar. (FA600 = #6 bar.) All dimensions are out - to - out of bar.
5. Minimum lap splice lengths for FA500 and FB700 shall be in accordance with Standard Specifications Subsection 503.07, Splicing.
6. The quantities of reinforcing bars shown are for one barrier end only.
7. Bolt holes in concrete shall be formed by a method approved by the Resident.
8. Payment for threaded rods and bearing plates will be considered incidental to the concrete barrier pay item.
9. Permanent Concrete Barrier is designed for attachment of Bridge Transition Type "IA" unless otherwise indicated on the Plans. Refer to Section 606 for details.
10. After installation of the guardrail is complete, upset the threads on the threaded rods in 3 places around each rod, at the junction of the nut and the exposed thread, with a center punch or similar tool.

MATERIALS:

Concrete ..... Class "LP"  
Reinforcing Steel ..... AASHTO M 31M/M 31, Grade 60  
Bearing Plate ..... AASHTO M 270M/M 270, Grade 36 (Galvanized)  
Threaded rods ..... AASHTO M 314, Grade 105 (Galvanized)

PERMANENT CONCRETE BARRIER  
526(21)

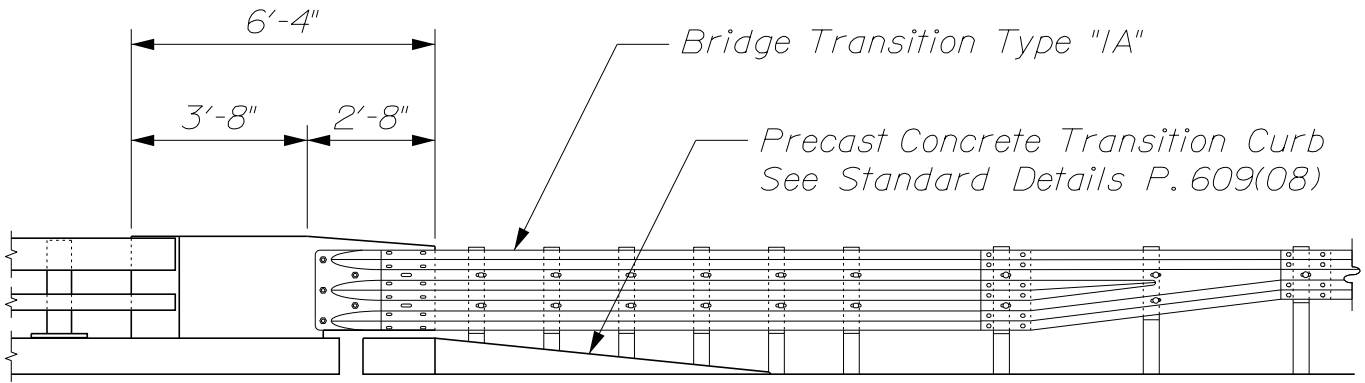

~ CONCRETE TRANSITION BARRIER ~  
 (2 - Bar Traffic Railing)

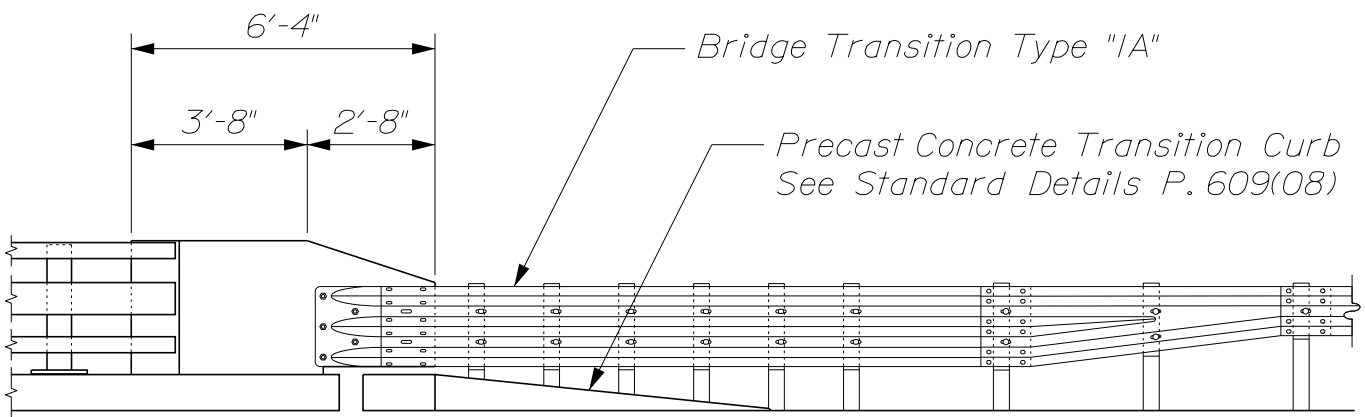

~ CONCRETE TRANSITION BARRIER ~  
 (3 - Bar Traffic / Bicycle Railing)  
 (4 - Bar Traffic / Bicycle Railing similar)

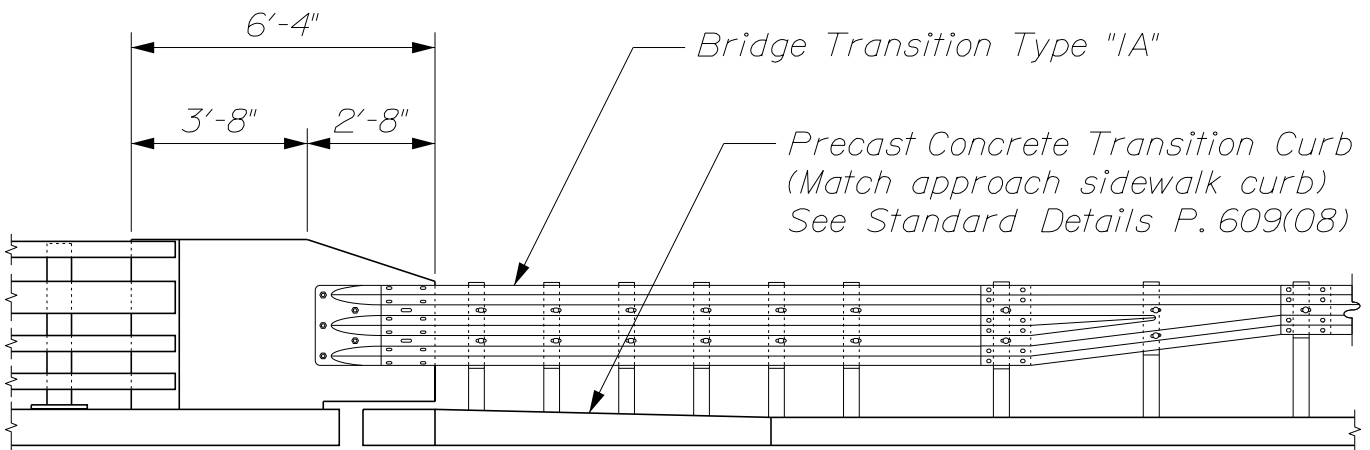

~ CONCRETE TRANSITION BARRIER ~  
 (4 - Bar Traffic / Pedestrian Railing)

CONCRETE TRANSITION BARRIER  
 526(22)



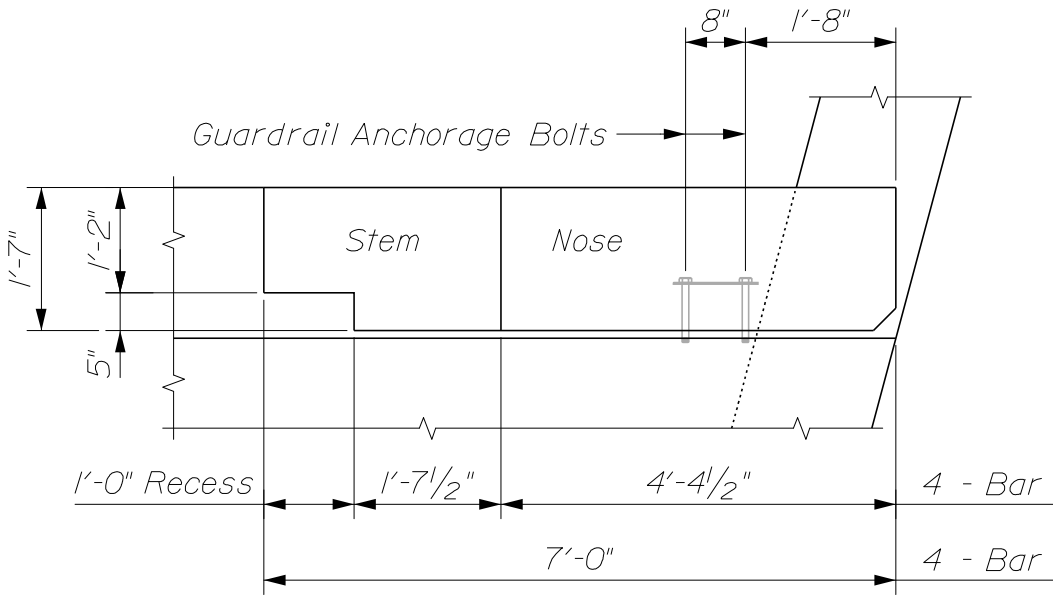

~ TRANSITION BARRIER PLAN ~

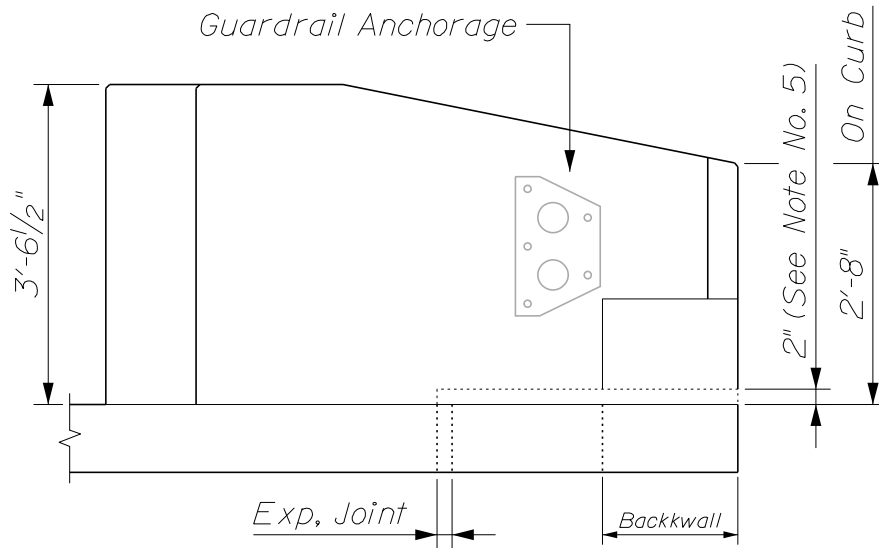

~ TRANSITION BARRIER ELEVATION ~  
 4 - Bar Traffic & Pedestrian Railing On Sidewalk

CONCRETE TRANSITION BARRIER  
 526(23)A

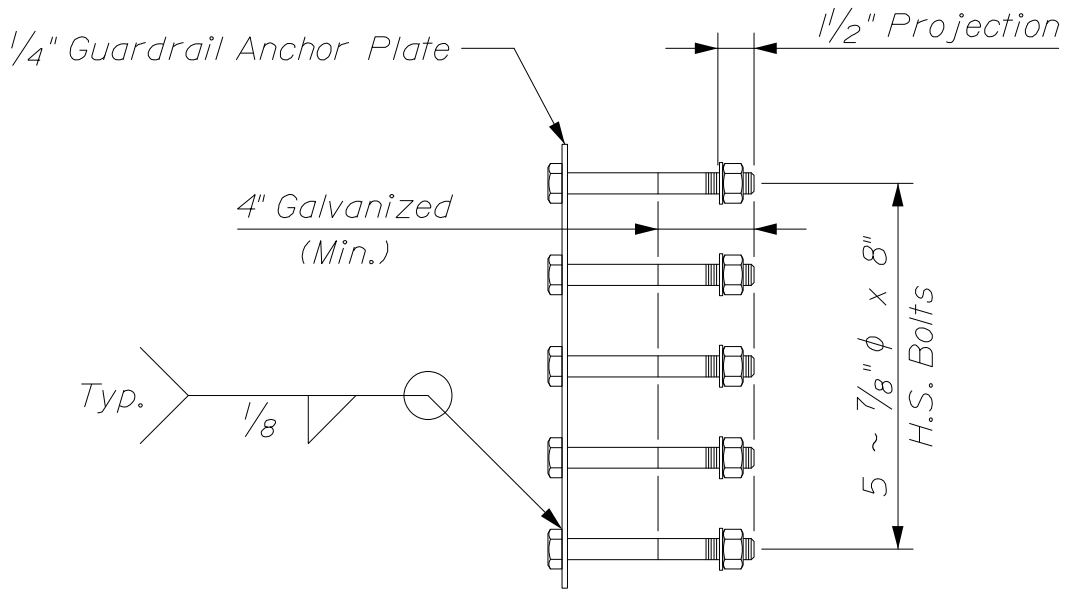

~ GUARDRAIL ANCHORAGE SECTION ~

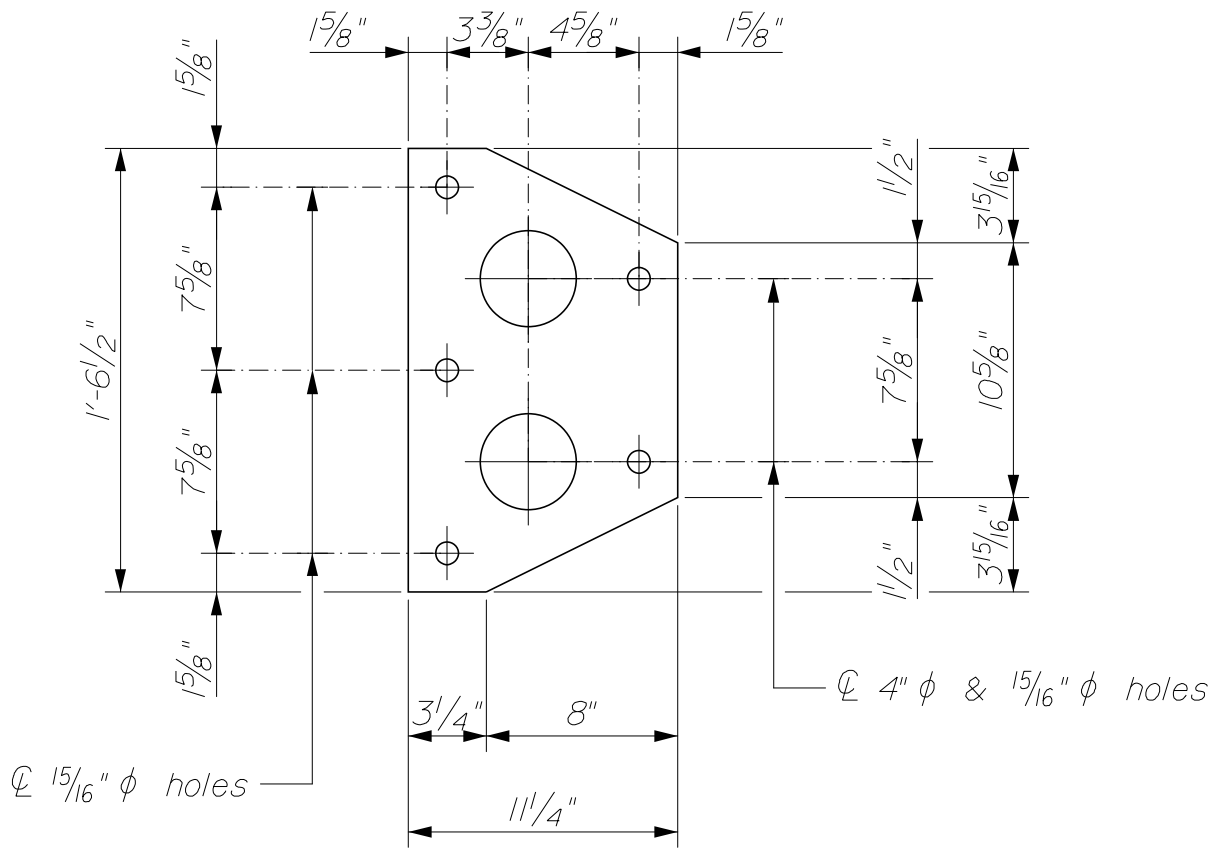

~ GUARDRAIL ANCHOR PLATE ~

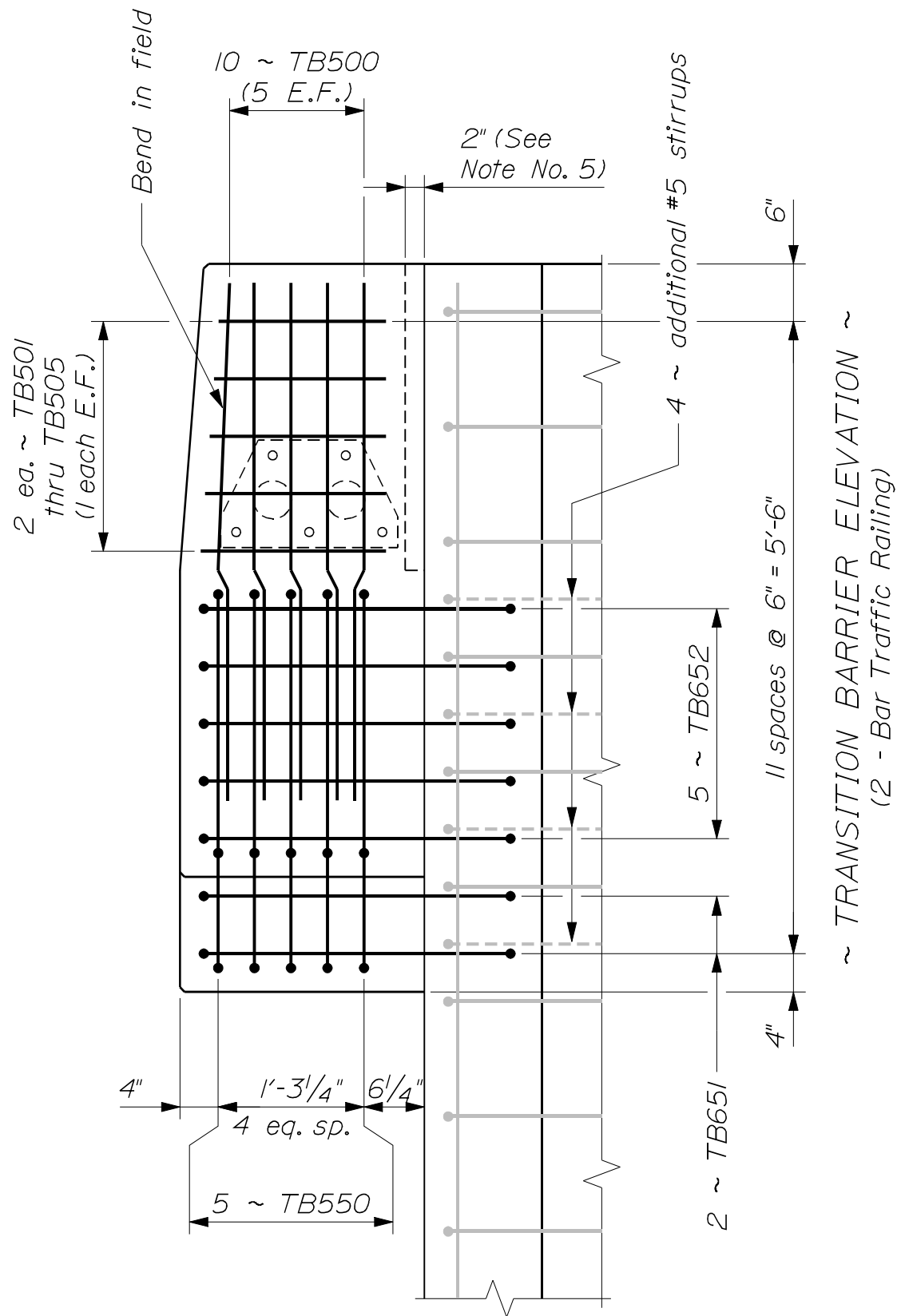

CONCRETE TRANSITION BARRIER  
526(25)

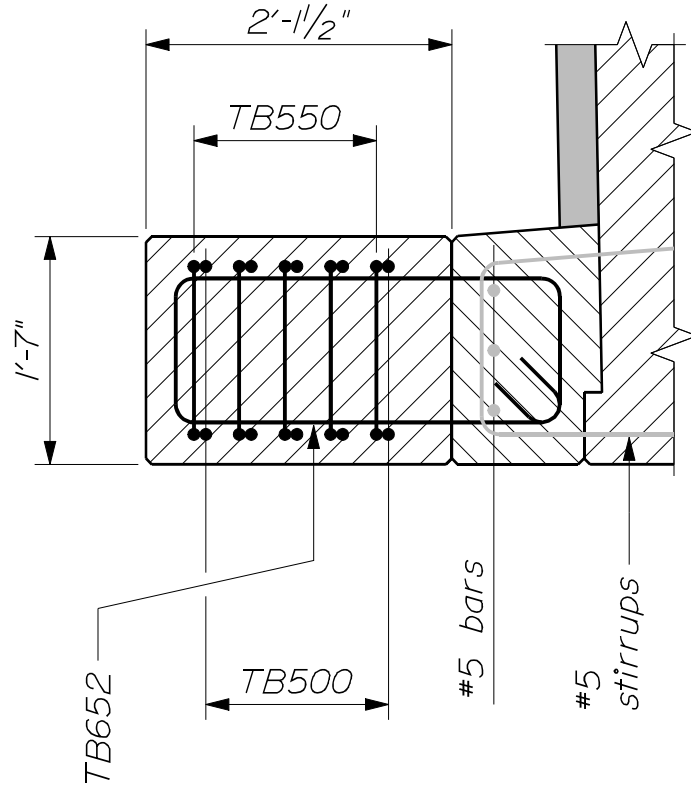

~ SECTION THRU STEM ~  
 (2 - Bar Traffic Railing)

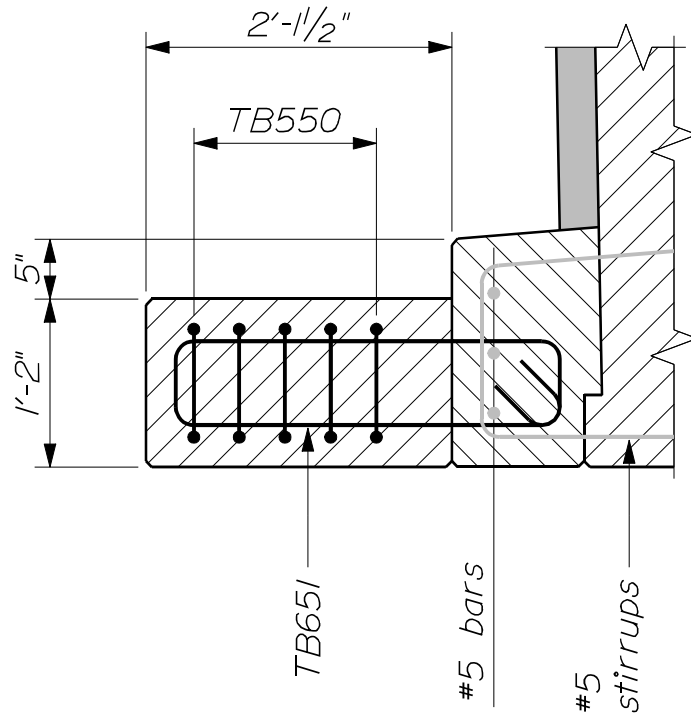

~ SECTION THRU RECESS ~  
 (2 - Bar Traffic Railing)

CONCRETE TRANSITION BARRIER  
 526(26)

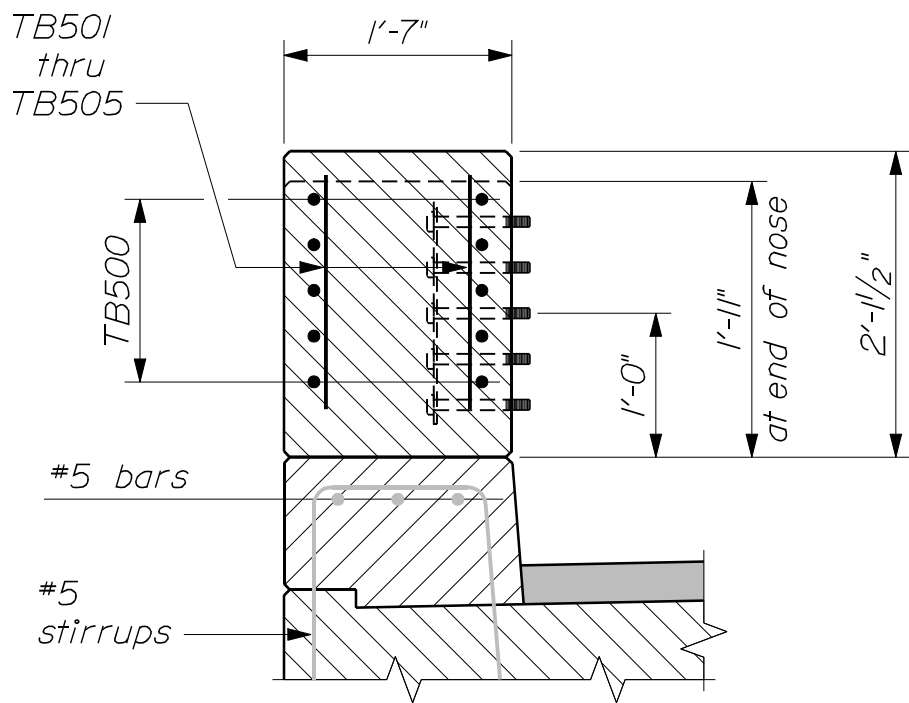

~ SECTION THRU NOSE ~  
 (2 - Bar Traffic Railing)

CONCRETE TRANSITION BARRIER  
 526(27)

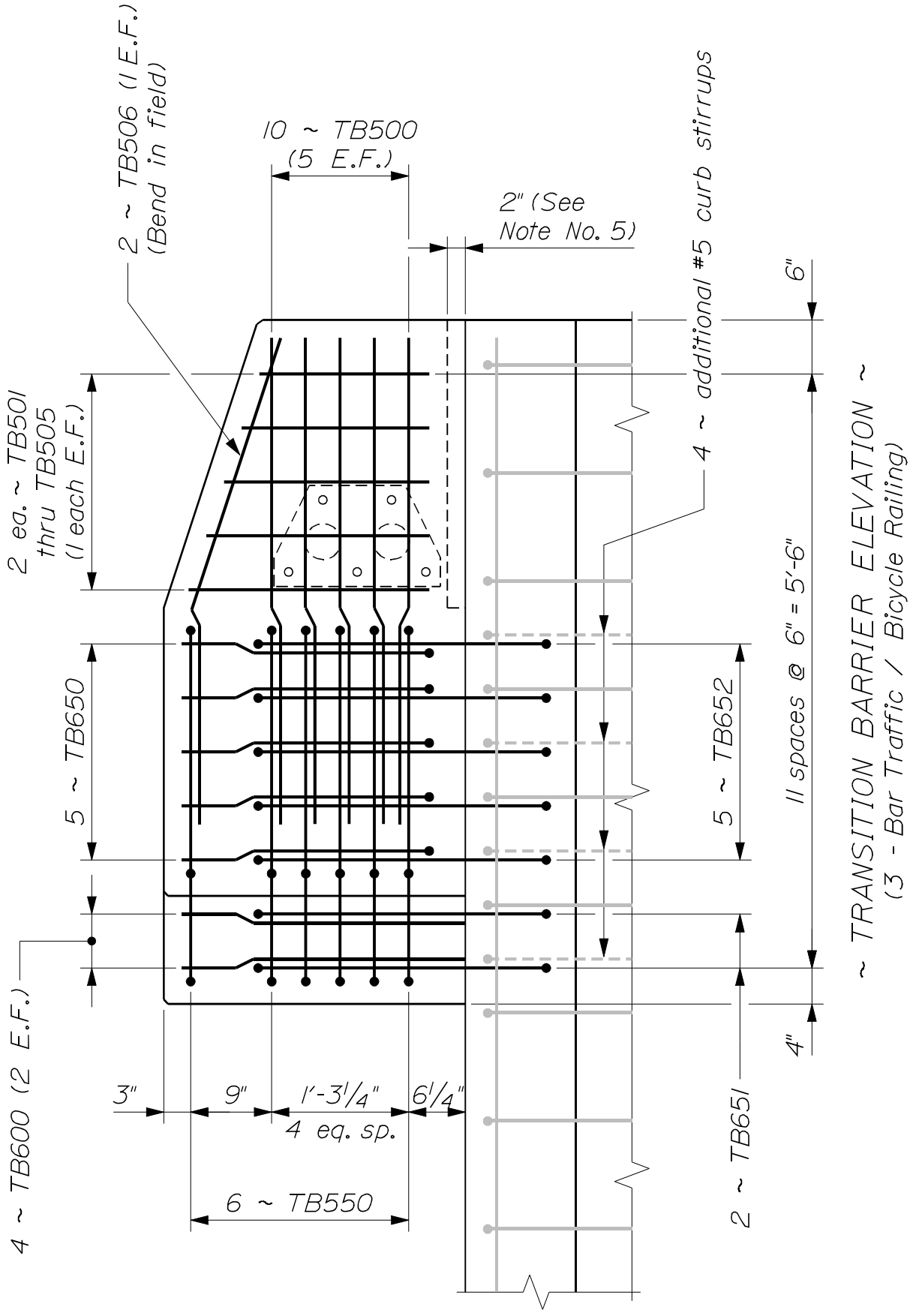

CONCRETE TRANSITION BARRIER  
526(28)

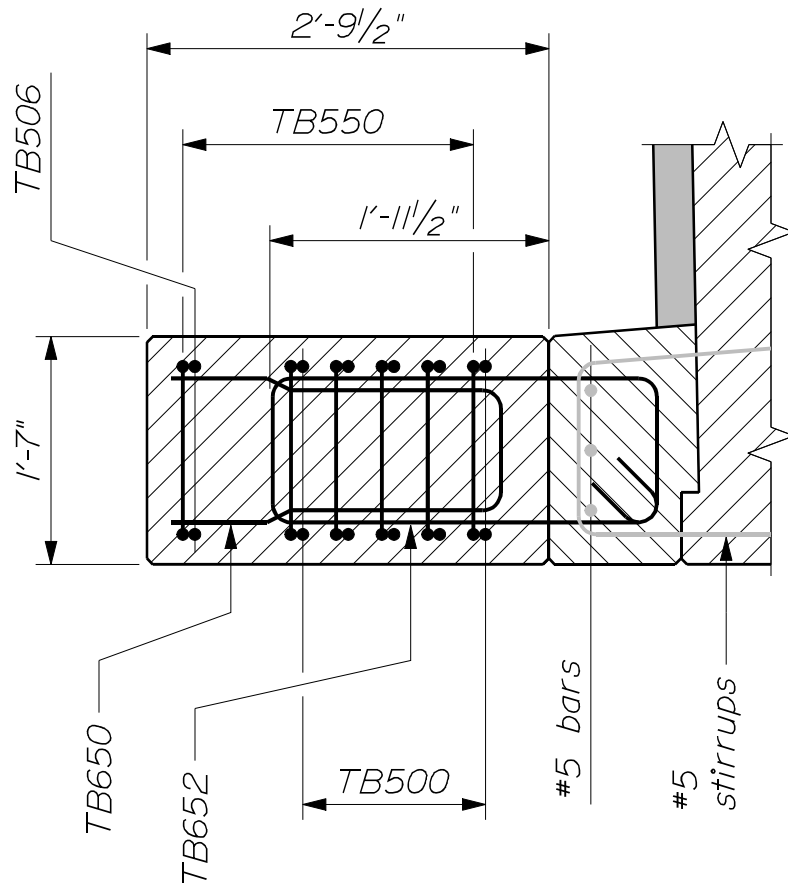

~ SECTION THRU STEM ~  
 (3 - Bar Traffic / Bicycle Railing)

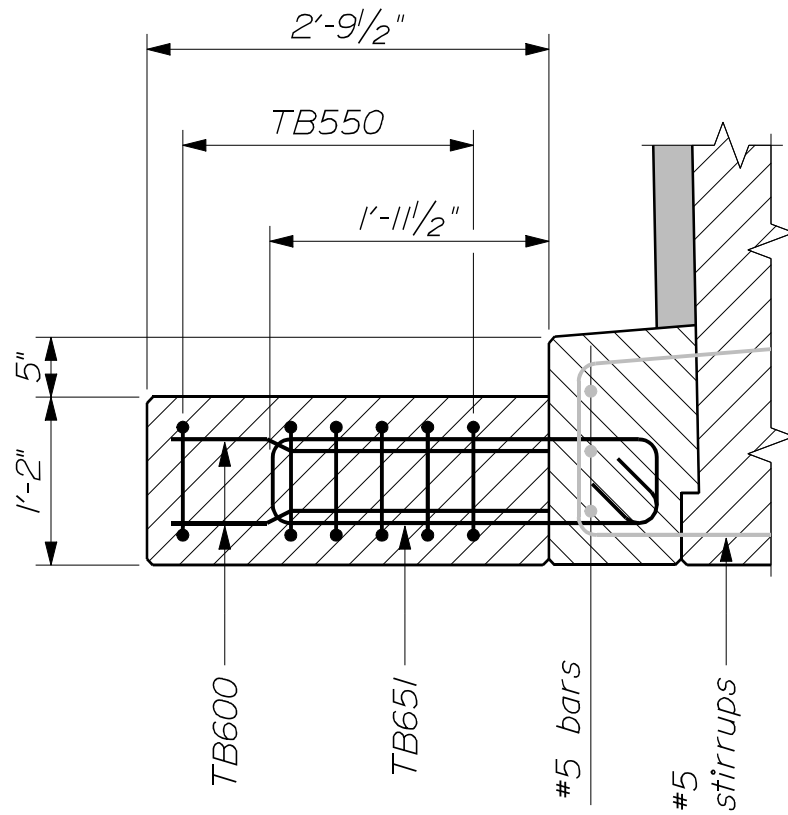

~ SECTION THRU RECESS ~  
 (3 - Bar Traffic / Bicycle Railing)

CONCRETE TRANSITION BARRIER  
 526(29)

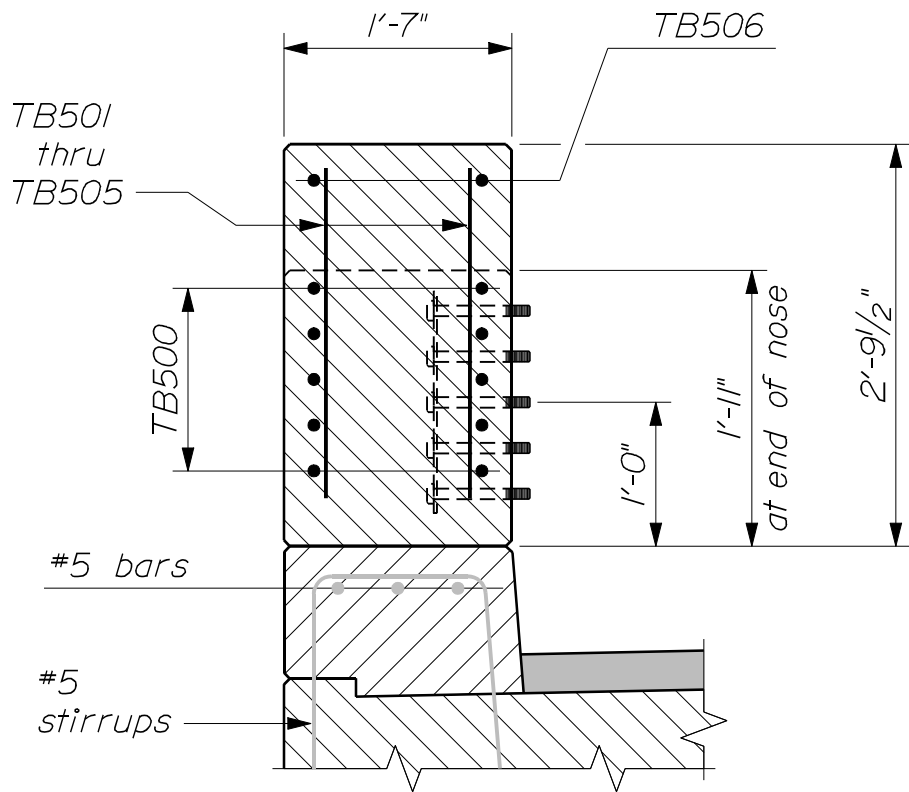

~ SECTION THRU NOSE ~  
 (3 - Bar Traffic / Bicycle Railing)

CONCRETE TRANSITION BARRIER  
 526(30)

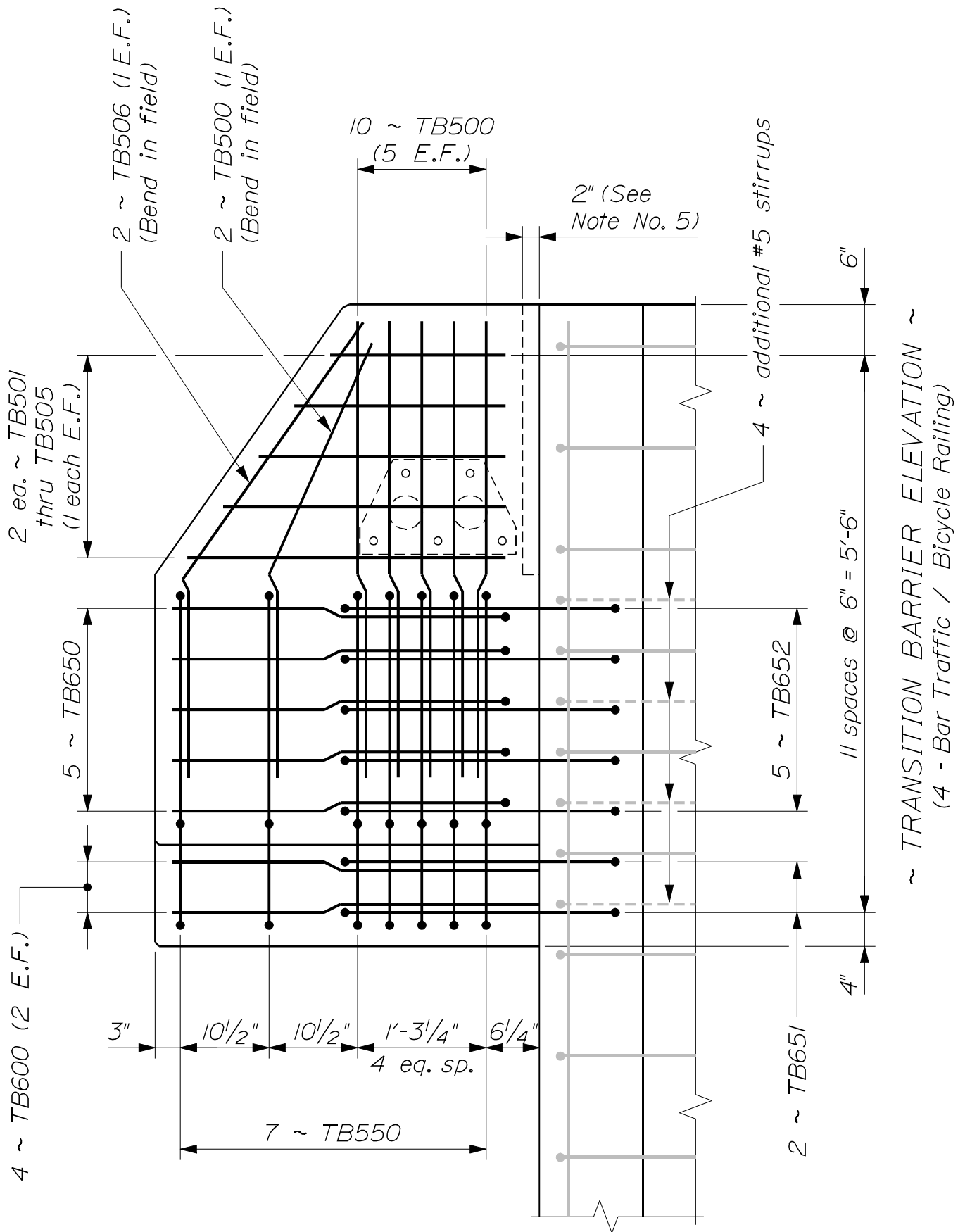

CONCRETE TRANSITION BARRIER  
526(31)

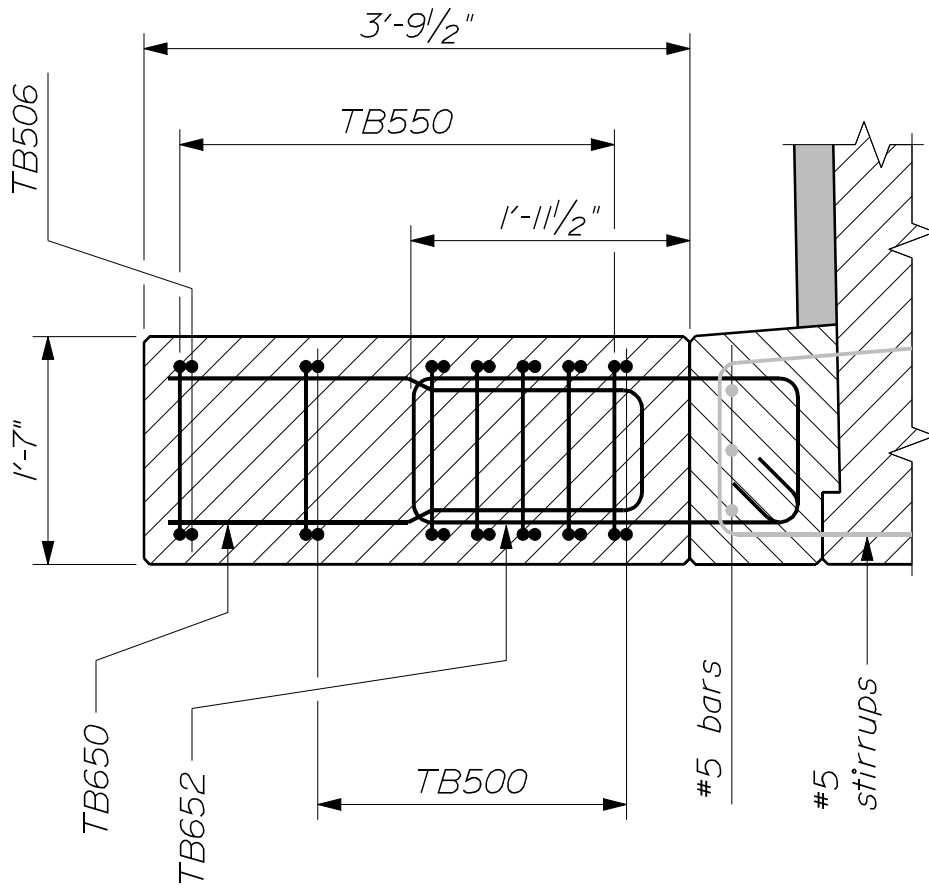

~ SECTION THRU STEM ~  
 (4 - Bar Traffic / Bicycle Railing)

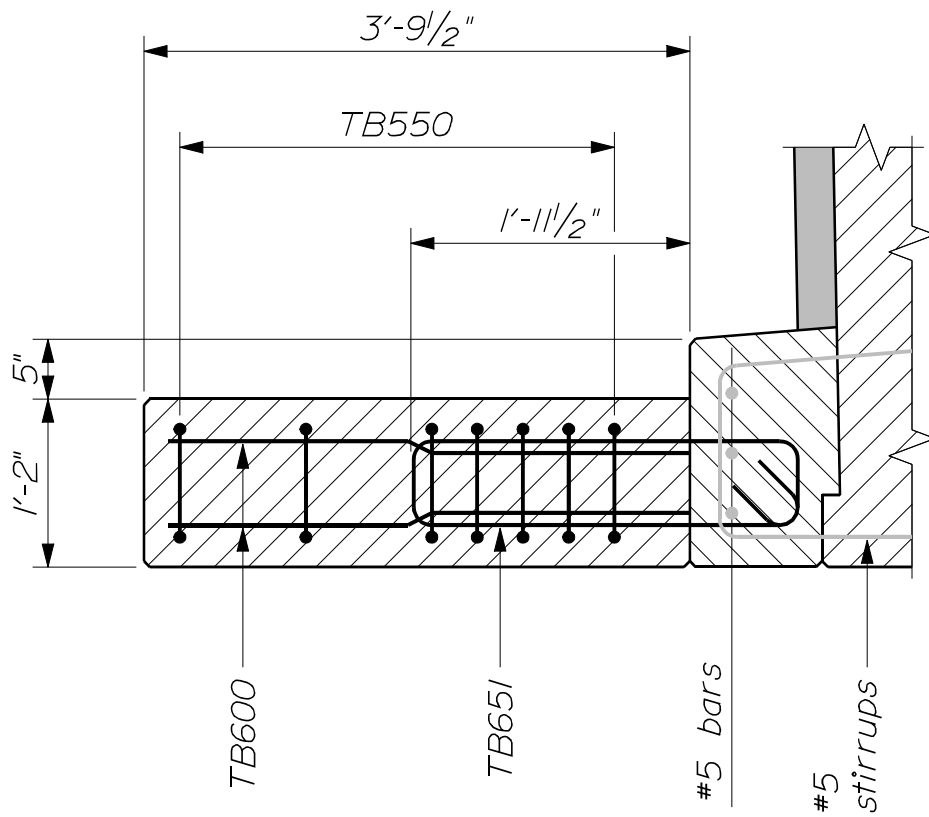

~ SECTION THRU RECESS ~  
 (4 - Bar Traffic / Bicycle Railing)

CONCRETE TRANSITION BARRIER  
 526(32)

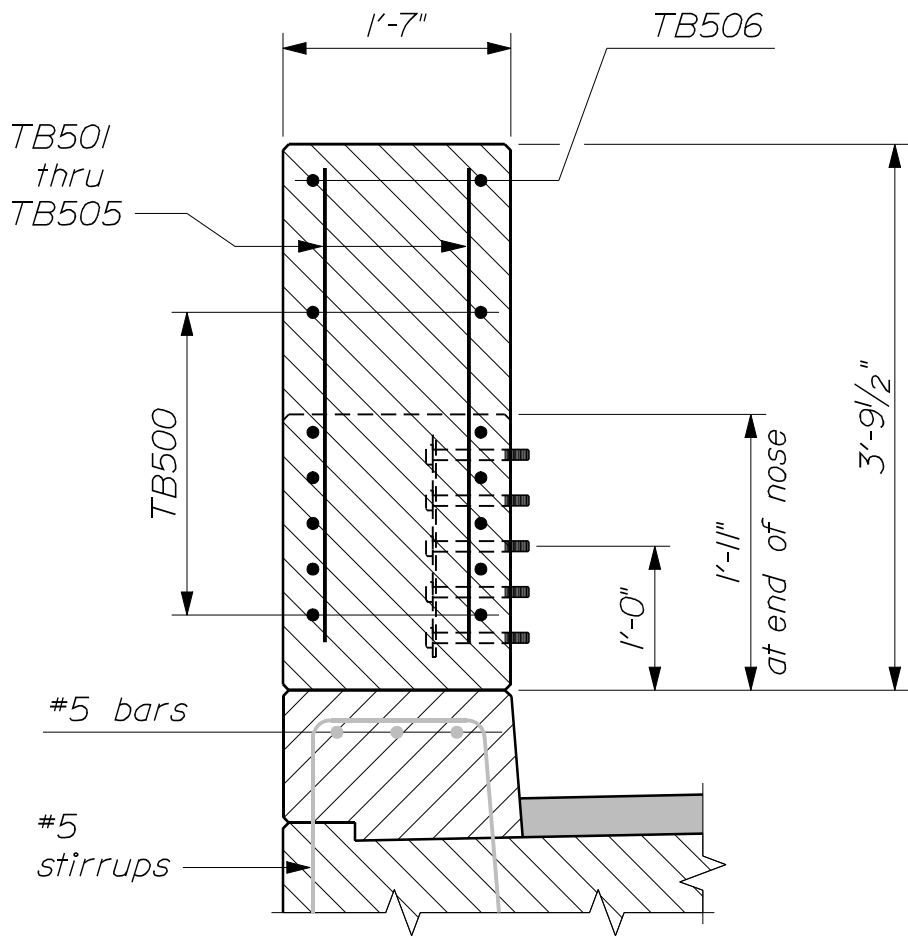

~ SECTION THRU NOSE ~  
 (4 - Bar Traffic / Bicycle Railing)

CONCRETE TRANSITION BARRIER  
 526(33)

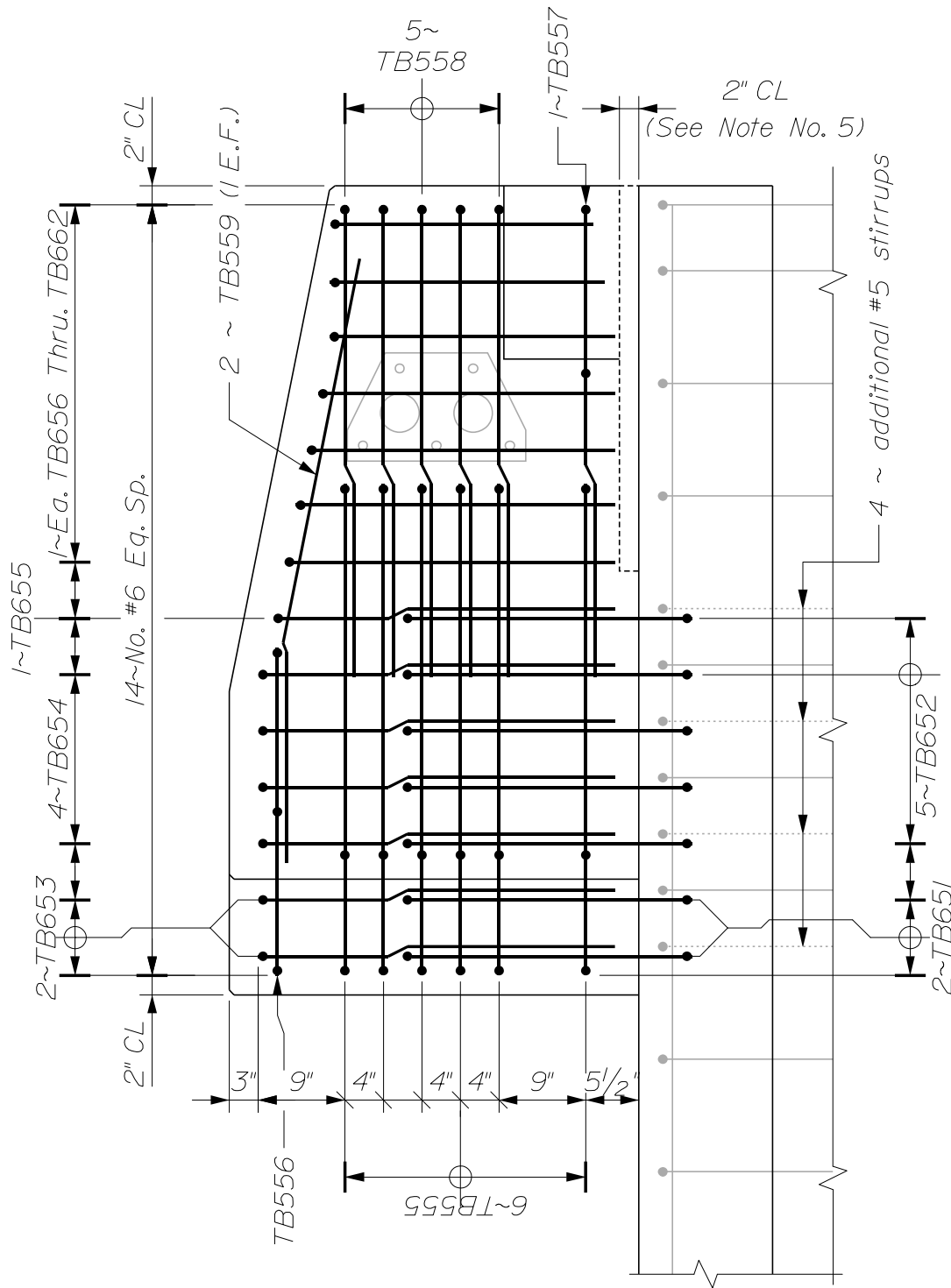

~ TRANSITION BARRIER ELEVATION ~  
 4 - Bar Traffic & Pedestrian Railing

CONCRETE TRANSITION BARRIER  
 526(34)

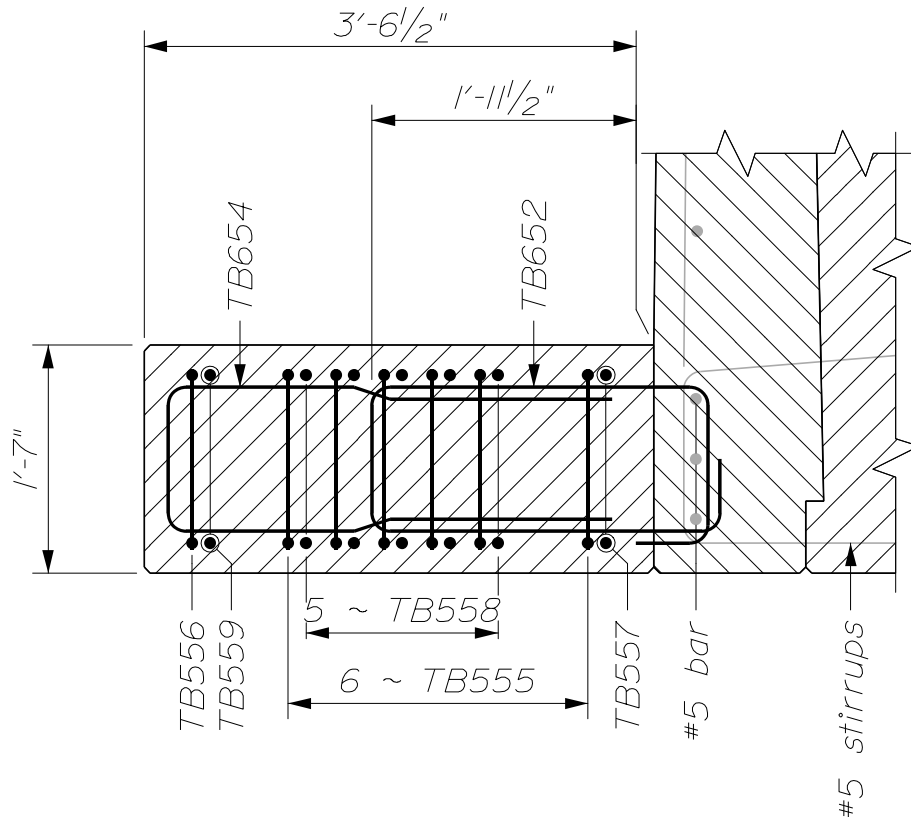

~ SECTION THRU STEM ~  
 4 - Bar Traffic & Pedestrian Railing

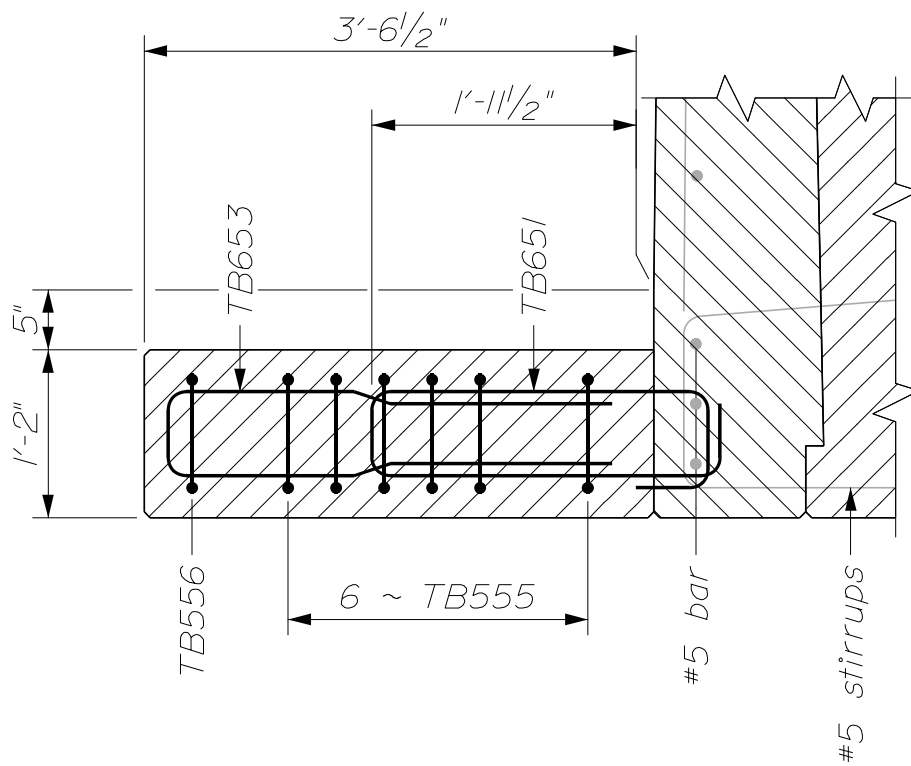

~ SECTION THRU RECESS ~  
 4 - Bar Traffic & Pedestrian Railing

CONCRETE TRANSITION BARRIER  
 526(35)

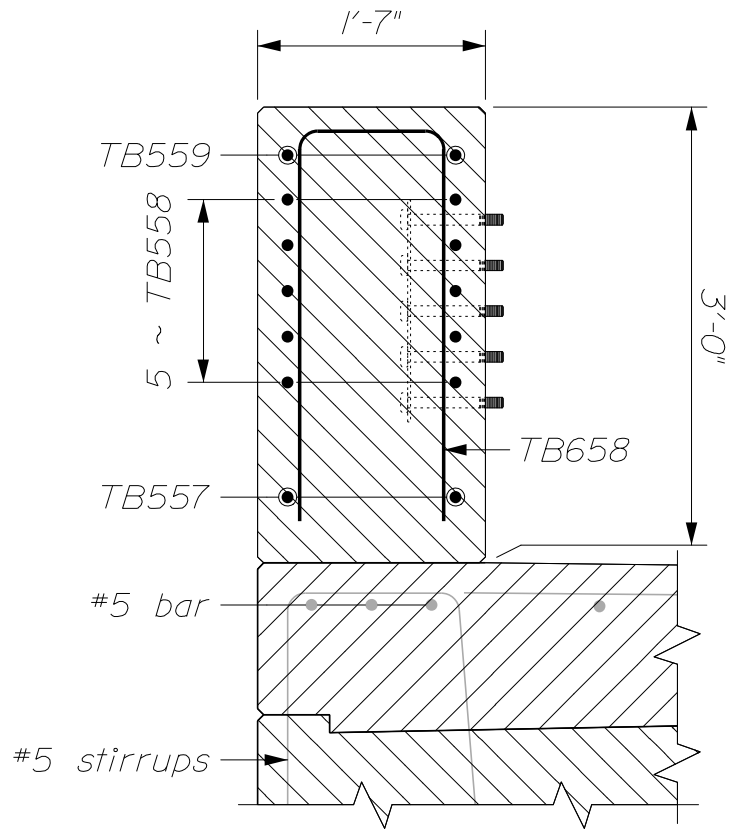

~ SECTION THRU NOSE ~  
4 - Bar Traffic & Pedestrian Railing

CONCRETE TRANSITION BARRIER  
526(36)

REINFORCING STEEL SCHEDULE						
	2 - Bar Traffic		3 - Bar Bike		4 - Bar Bike	
	Qty.	Length	Qty.	Length	Qty.	Length
TB500	10	4'-6"	10	4'-6"	12	4'-6"
TB501	2	1'-8"	2	2'-2"	2	3'-2"
TB502	2	1'-7"	2	2'-0"	2	2'-10"
TB503	2	1'-7"	2	1'-10"	2	2'-6"
TB504	2	1'-6"	2	1'-8"	2	2'-2"
TB505	2	1'-6"	2	1'-6"	2	1'-10"
TB506	--	--	2	4'-8"	2	5'-1"
TB550	5	10'-2"	6	10'-2"	7	10'-2"
TB600	--	--	4	2'-7"	4	3'-7"
TB650	--	--	5	5'-10"	5	7'-10"
TB651-A*	2	7'-11"	2	7'-11"	2	7'-11"
TB651-C*	2	7'-5"	2	7'-5"	2	7'-5"
TB652-A*	5	8'-9"	5	8'-9"	5	8'-9"
TB652-C*	5	8'-3"	5	8'-3"	5	8'-3"

**Notes:**

The first digit following the letters of the mark indicate the size of the reinforcing bar. (TB500 = bar size #5.) All dimensions are out - to - out of bar.

Quantities given are for one Transition Barrier.

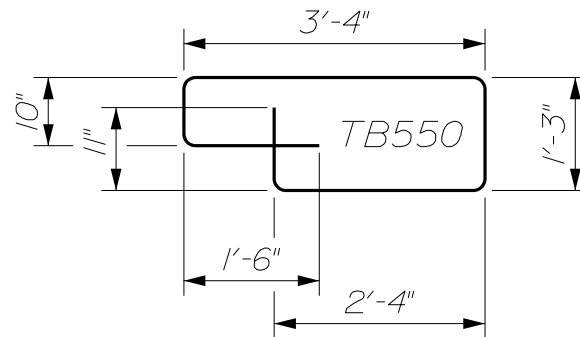

\*TB65x-A is used with Asphalt Wearing Surface.  
\*TB65x-C with Integral Concrete Wearing Surface.

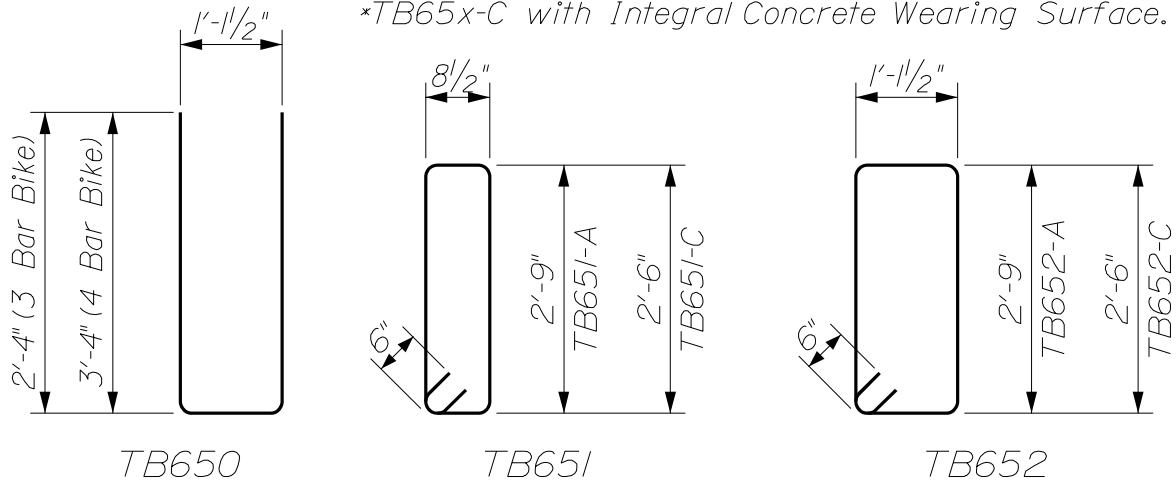

CONCRETE TRANSITION BARRIER  
526(37)

## REINFORCING STEEL SCHEDULE

### 4 - Bar Traffic & Pedestrian Railing

Mark	Qty.	Length	Type	A	B	C	D	E	F
TB555	6	12'-0"	1TB	1'-6"	0'-10"	4'-3"	1'-3"	3'-3"	0'-11"
TB556	1	9'-2"	1TB	1'-6"	0'-10"	2'-10"	1'-3"	1'-10"	0'-11"
TB557	1	9'-1 1/2"	2TB	4'-1"	0'-11"	1'-4 1/2"	2'-9"		
TB558	5	9'-5"	3TB	4'-1"	1'-3"	4'-1"			
TB559	2	5'-4"	6TB	1'-6"	3'-10"				
TB651	2	7'-1"	4TB	2'-4"	0'-8 1/2"	2'-4"	0'-8 1/2"	0'-6"	0'-6"
TB652	5	7'-11"	4TB	2'-4"	1'-1 1/2"	2'-4"	1'-1 1/2"	0'-6"	0'-6"
TB653	2	6'-10 1/2"	3TB	3'-1"	0'-8 1/2"	3'-1"			
TB654	4	7'-3 1/2"	3TB	3'-1"	1'-1 1/2"	3'-1"			
TB655	1	7'-1 1/2"	3TB	3'-0"	1'-1 1/2"	3'-0"			
TB656	1	6'-7 1/2"	3TB	2'-9"	1'-1 1/2"	2'-9"			
TB657	1	6'-5 1/2"	3TB	2'-8"	1'-1 1/2"	2'-8"			
TB658	1	6'-3 1/2"	3TB	2'-7"	1'-1 1/2"	2'-7"			
TB659	1	6'-1 1/2"	3TB	2'-6"	1'-1 1/2"	2'-6"			
TB660	1	5'-10 1/2"	5TB	0'-11"	0'-3 3/4"	1'-5"	1'-1 1/2"	2'-4"	
TB661	1	5'-10"	5TB	1'-0"	0'-2 1/4"	1'-3"	1'-1 1/2"	2'-3"	
TB662	1	5'-9"	5TB	1'-0"	0'-3 3/4"	1'-2"	1'-1 1/2"	2'-2"	

**Notes:**

The first digit following the letters of the mark indicate the size of the reinforcing bar. (TB500 = bar size #5.) All dimensions are out - to - out of bar.

Quantities given are for one Transition Barrier.

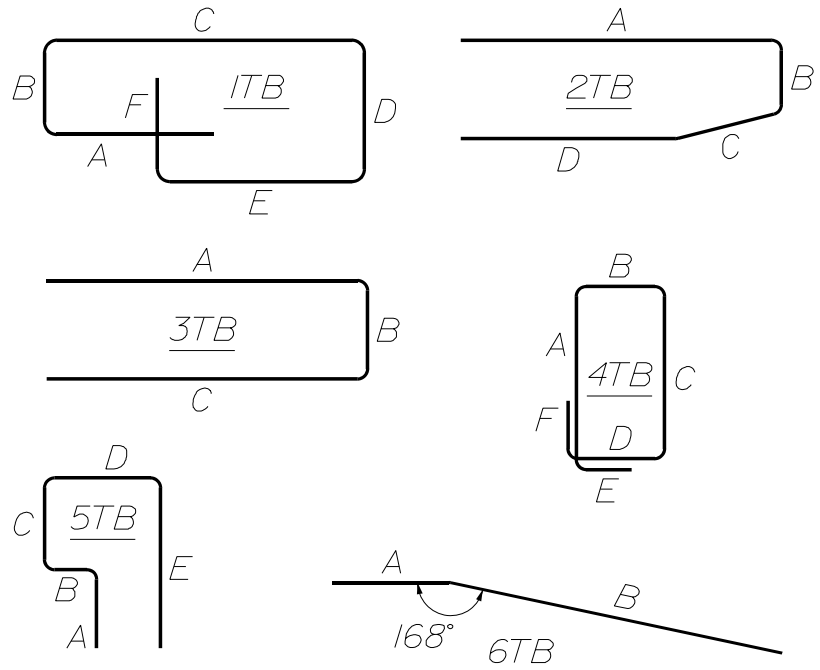

CONCRETE TRANSITION BARRIER  
526(37)A

NOTES:

1. All work and materials shall conform to the provisions of Standard Specifications Section 526 - Concrete Barrier.
2. The Contractor is responsible for ensuring that vertical reinforcing bars TB651 and TB652 are installed prior to placement of the curb or sidewalk concrete. Payment for these bars will be considered incidental to Item No. 526.34, Permanent Concrete Transition Barrier.
3. Reinforcing steel shall have a minimum concrete cover of 2 inches.
4. Quantities of reinforcing bars shown are for one transition barrier only.
5. When the Concrete Transition Barrier is cantilevered over an expansion joint, the nose shall be blocked out as shown.
6. Payment for guardrail anchorage will be considered incidental to the transition barrier pay item.
7. Precast Concrete Transition Curb shall meet the requirements of Standard Specifications Section 609 - Curb. The bridge end of the curb shall be saw cut in the field to fit flush against the backwall, as dictated by the bridge skew angle and the profile grade. Where curbing is specified on the adjacent highway, the transition shall be modified accordingly. Payment for transition curb will be considered incidental to the Concrete Transition Barrier pay item.
8. Concrete Transition Barrier is designed for attachment of Bridge Transition Type "IA" unless otherwise indicated on the Plans. Refer to Section 606 for details.
9. After installation of the guardrail is complete, upset the threads on the anchor bolts in three (3) places around each bolt, at the junction of the nut and the exposed thread, with a center punch or similar tool.

MATERIALS:

Concrete .....Class "LP"  
Reinforcing Steel..... AASHTO M 31M/M 31, Grade 60  
Anchor Plate..... AASHTO M 270M/M 270, Grade 36 (Galvanized)  
Bolts ..... AASHTO M 314, Grade 105 (Galvanized)

CONCRETE TRANSITION BARRIER  
526(38)

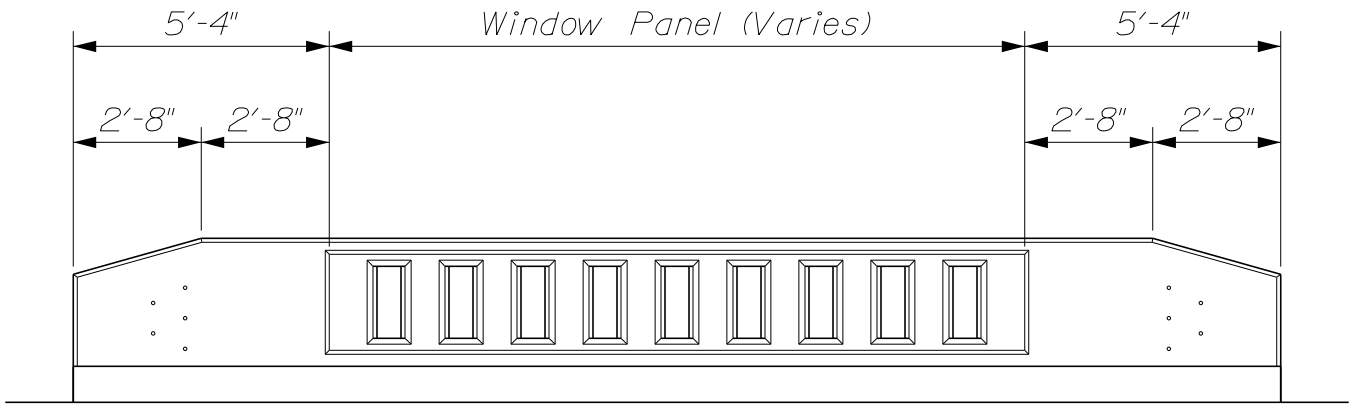

~ RAIL ELEVATION ~  
 (Traffic Rail shown; Sidewalk Rail similar)

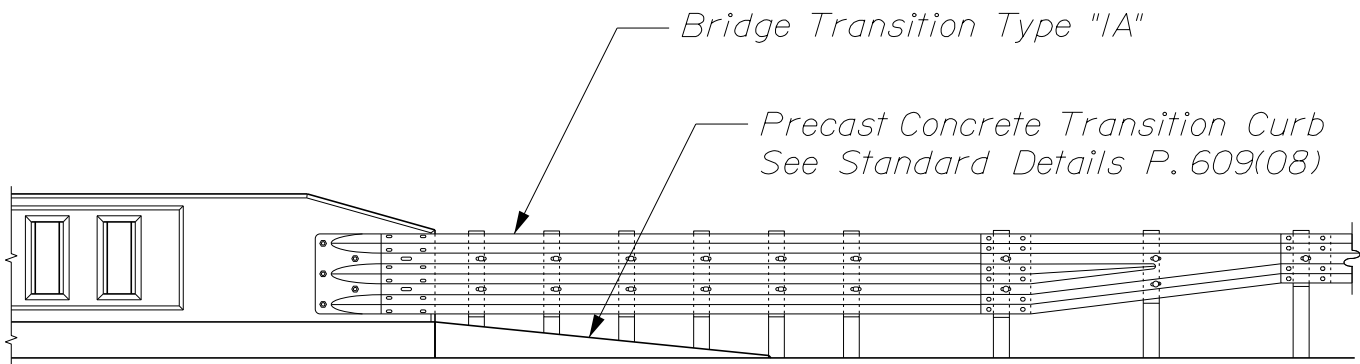

~ GUARDRAIL CONNECTION ~  
 (Traffic Rail)

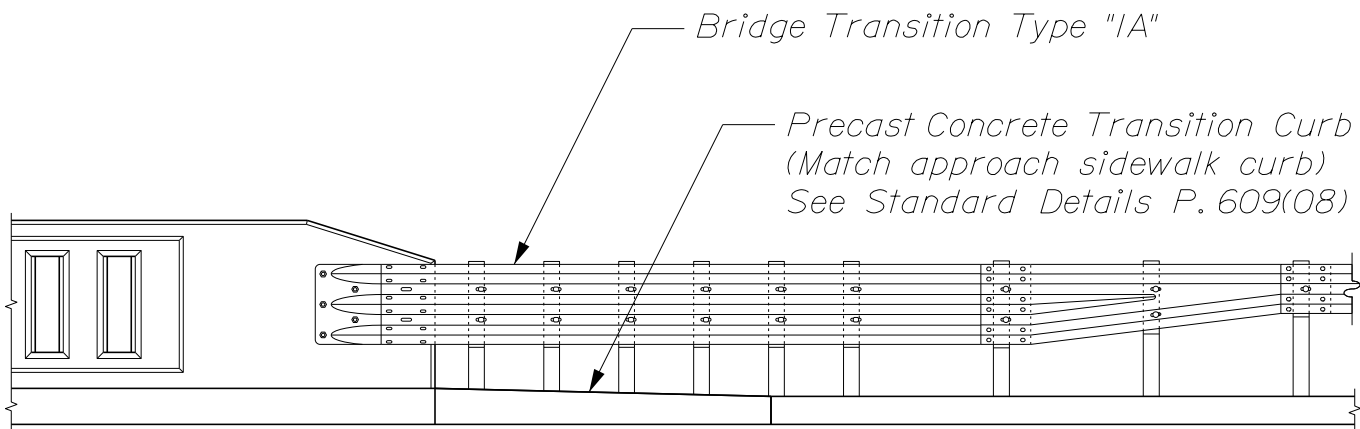

~ GUARDRAIL CONNECTION ~  
 (Sidewalk Rail)

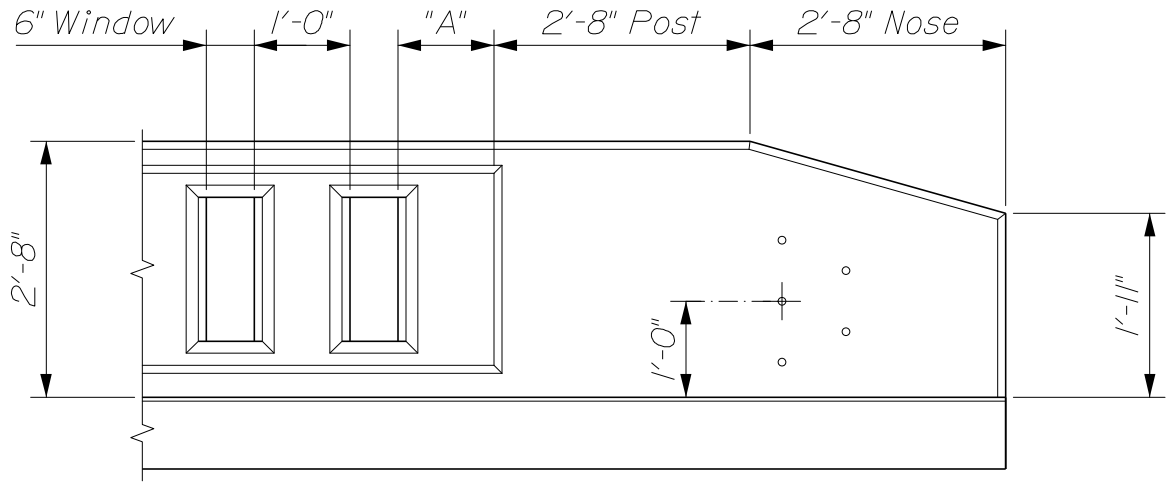

~ TRAFFIC RAIL END ELEVATION ~  
 (Non - cantilevered)

Dim. "A" shall be 6" min., 15" max. and approximately equal at all locations in any length of railing.

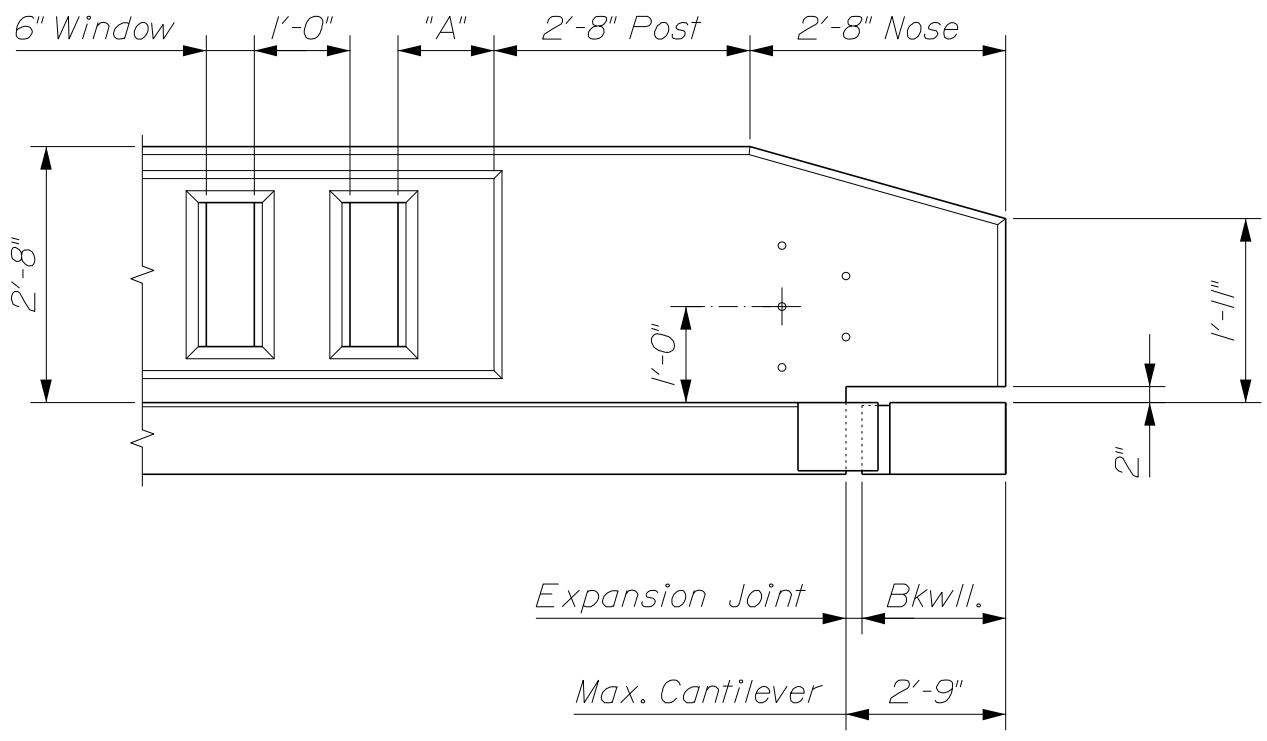

~ TRAFFIC RAIL END ELEVATION ~  
 (Cantilevered)

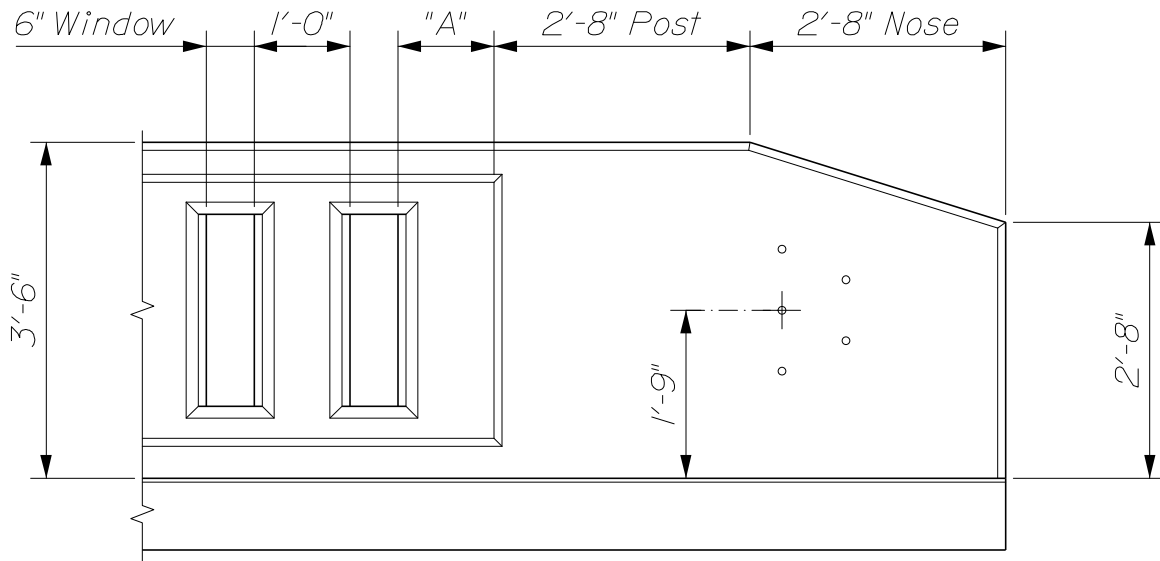

~ SIDEWALK RAIL END ELEVATION ~  
(Non - cantilevered)

Dim. "A" shall be 6" min., 15" max. and approximately equal at all locations in any length of railing.

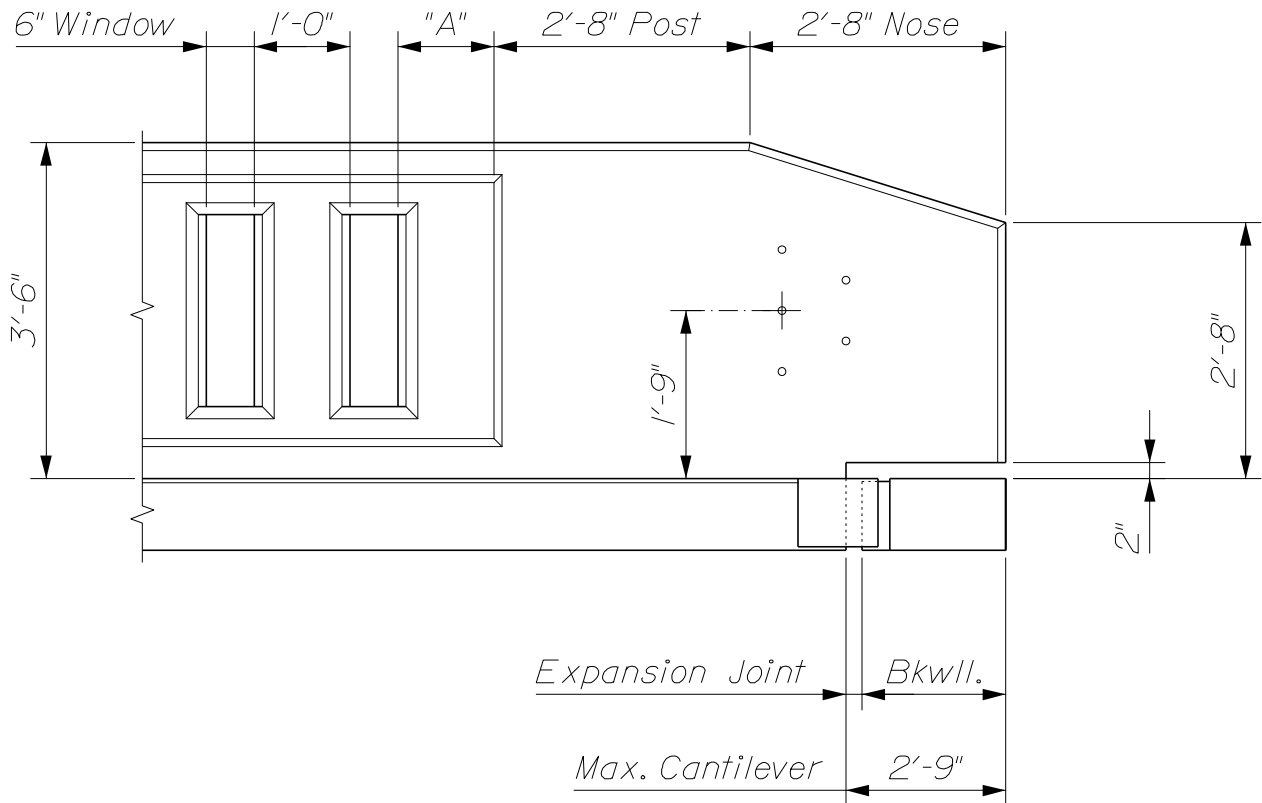

~ SIDEWALK RAIL END ELEVATION ~  
(Cantilevered)

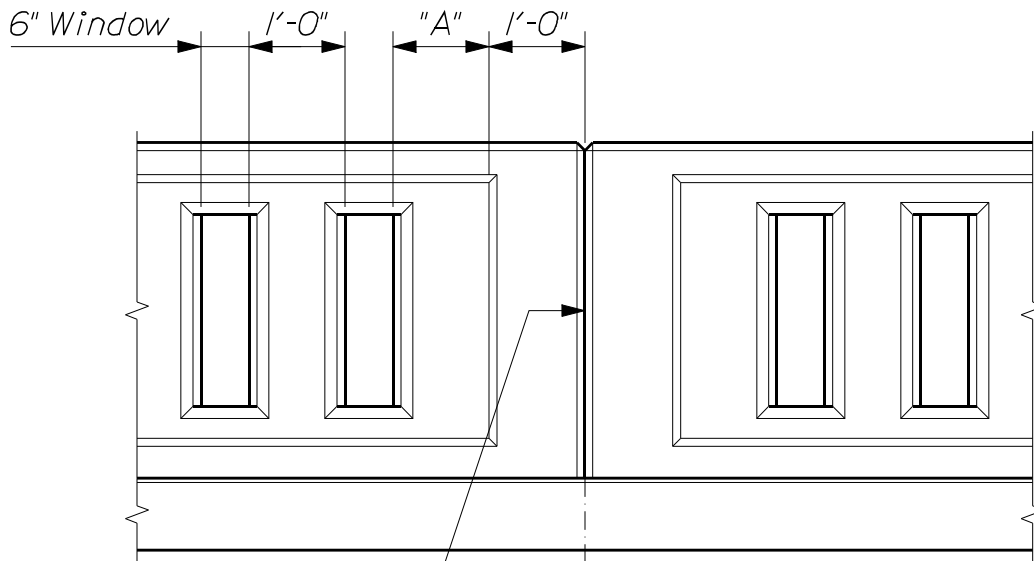

*Contraction Joint (No Key)*

*⊥ Pier or Intermediate Rail Joint*

~ *CONTRACTION JOINT ELEVATION* ~  
*(Sidewalk Rail shown)*

*Dim. "A" = 6" min., 15" max.*

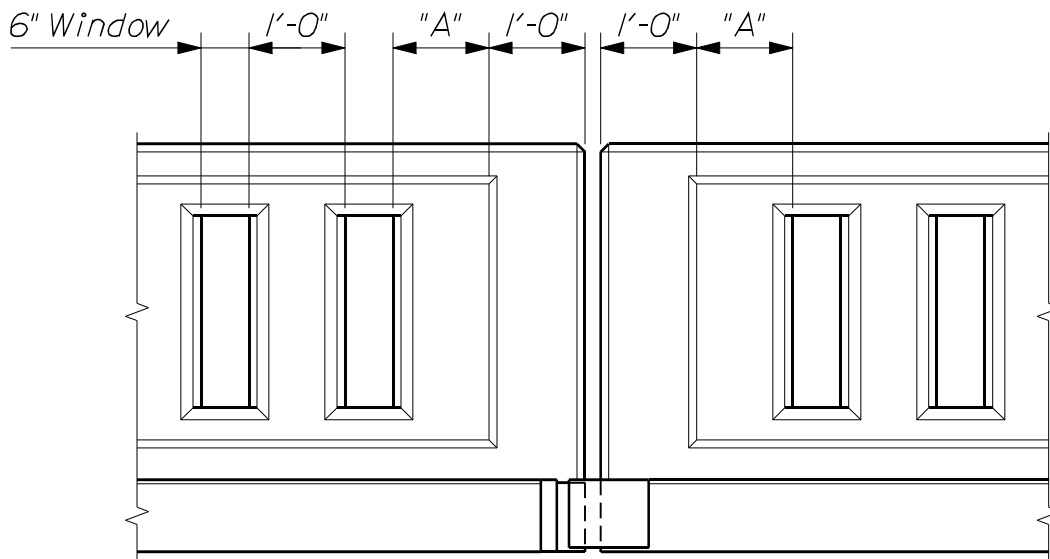

*Expansion Joint*

~ *EXPANSION JOINT ELEVATION* ~  
*(Sidewalk Rail shown)*

*TEXAS CLASSIC RAIL*  
*526(42)*

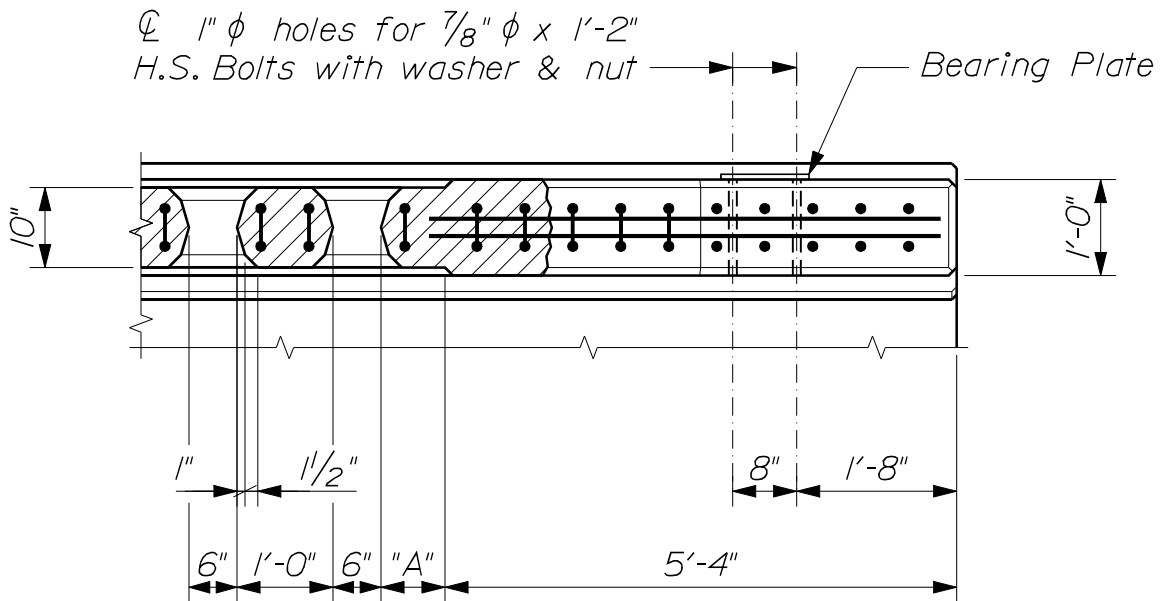

~ TRAFFIC RAIL PLAN ~

E.F. = Each Face

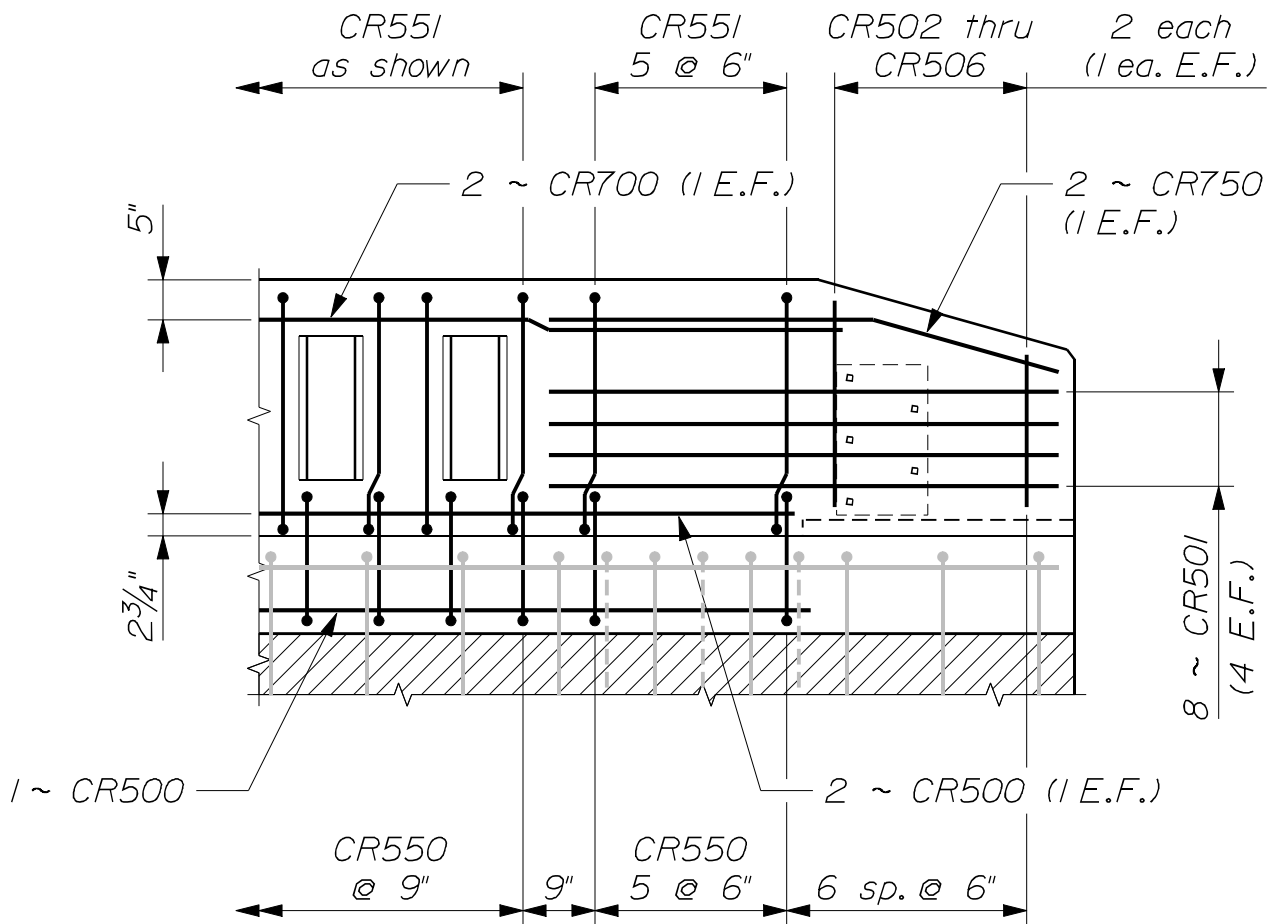

~ TRAFFIC RAIL ELEVATION ~

TEXAS CLASSIC RAIL  
 526(43)

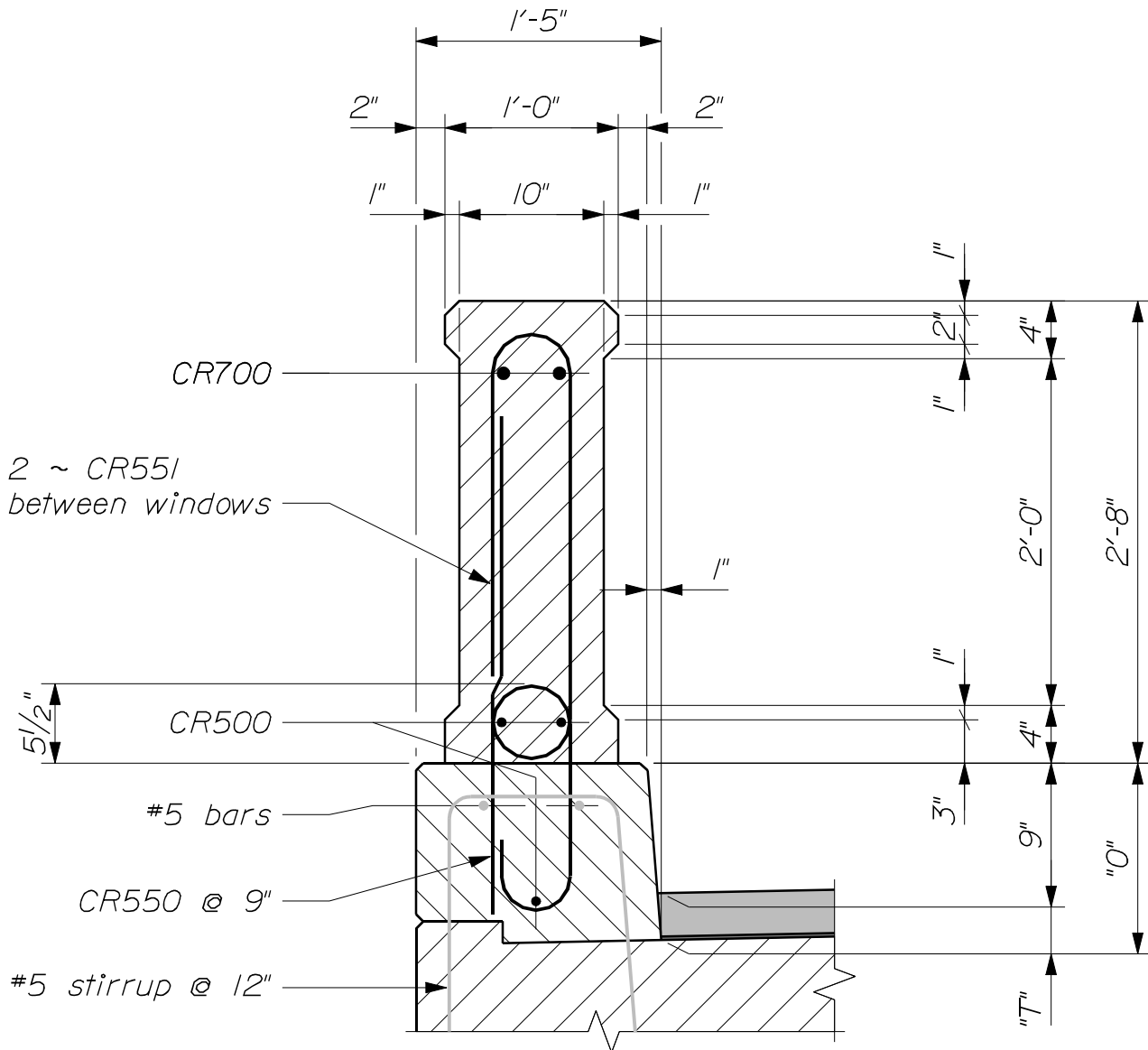

~ SECTION BETWEEN WINDOWS ~  
(Traffic Rail)

For Wearing Surface ("T") details, refer to Section 502 - Concrete Curb

TABLE OF DIMENSIONS 		
Wearing Surface Type	"T"	"O"
Bituminous	3 1/4"	1'-0 1/4"
Unreinforced Concrete	2"	11"
Integral	0"	9"

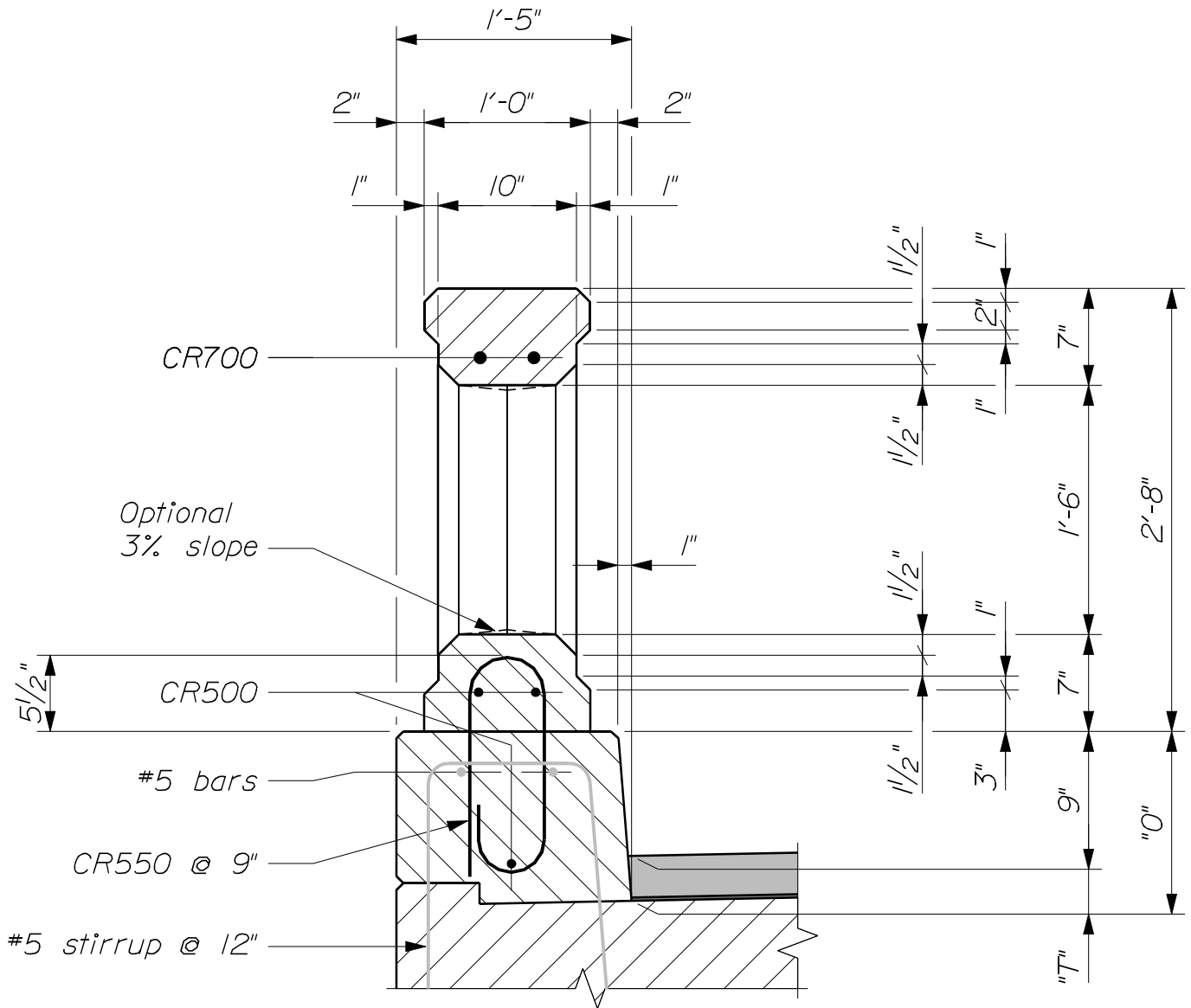

~ SECTION THROUGH WINDOW ~  
 (Traffic Rail)

For Wearing Surface ("T") details, refer to Section 502 - Concrete Curb

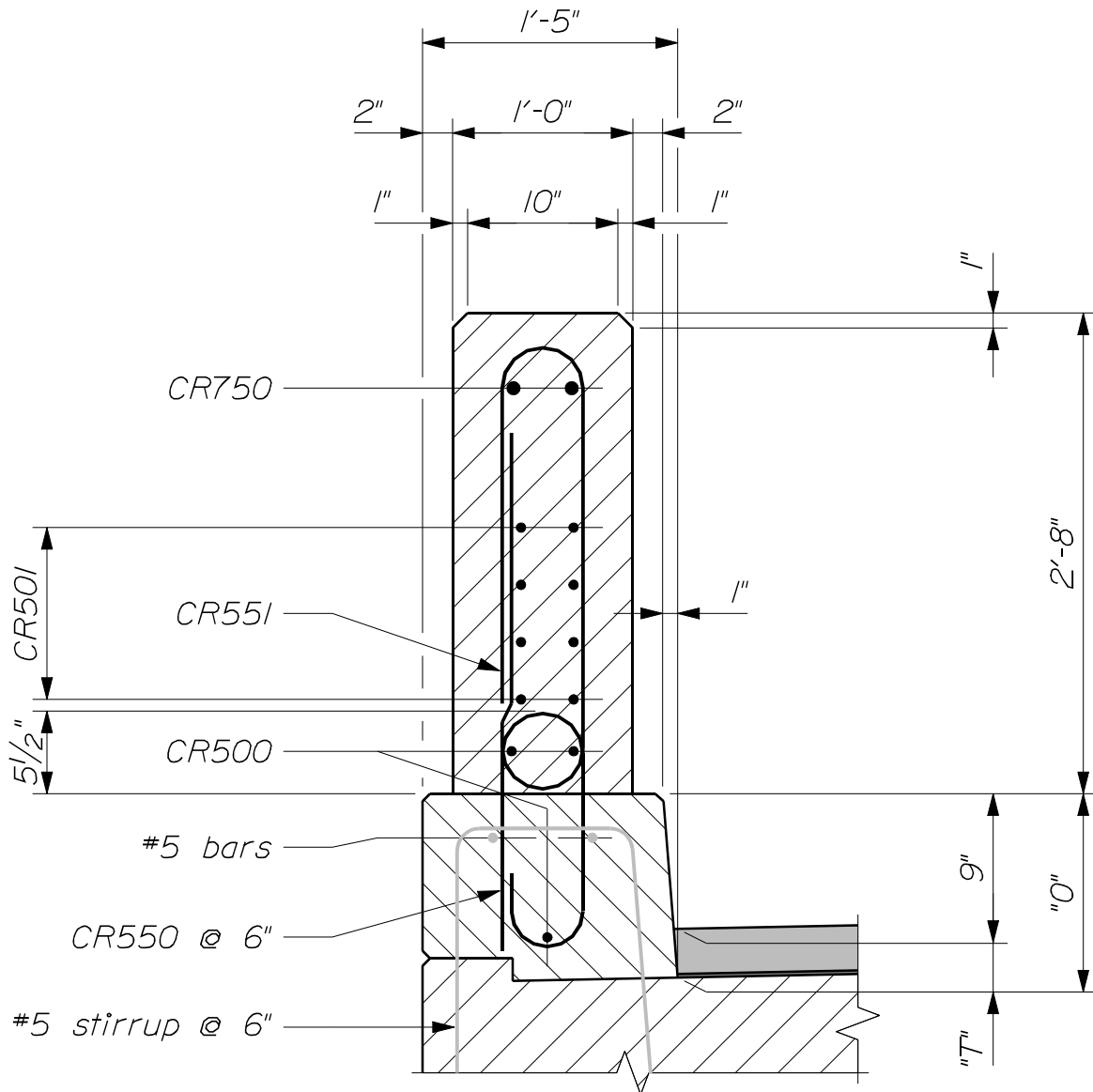

~ SECTION THROUGH POST ~  
 (Traffic Rail)

For Wearing Surface ("T") details, refer to Section 502 - Concrete Curb

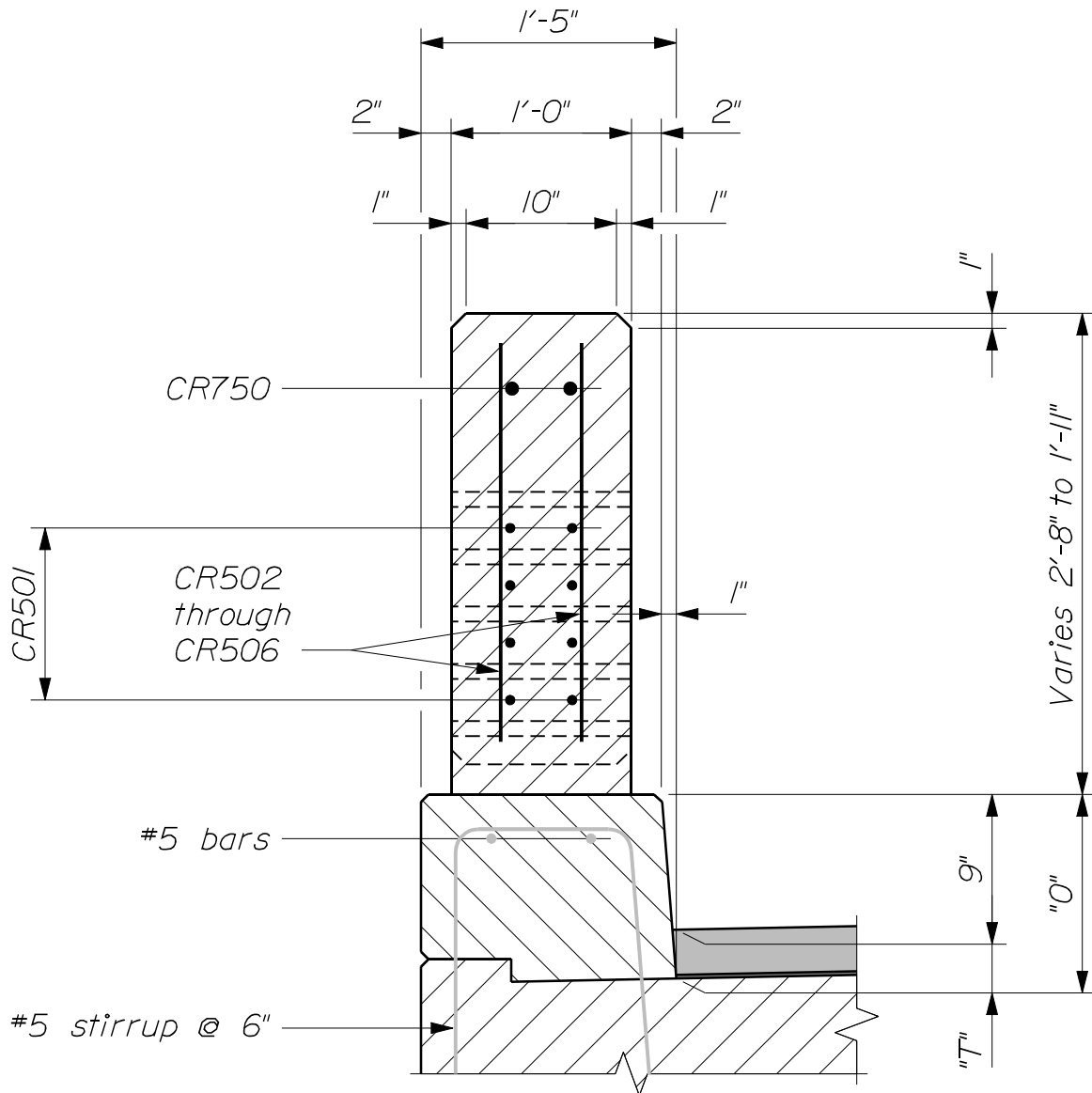

~ SECTION THROUGH NOSE ~  
 (Traffic Rail)

For Wearing Surface ("T") details, refer to Section 502 - Concrete Curb

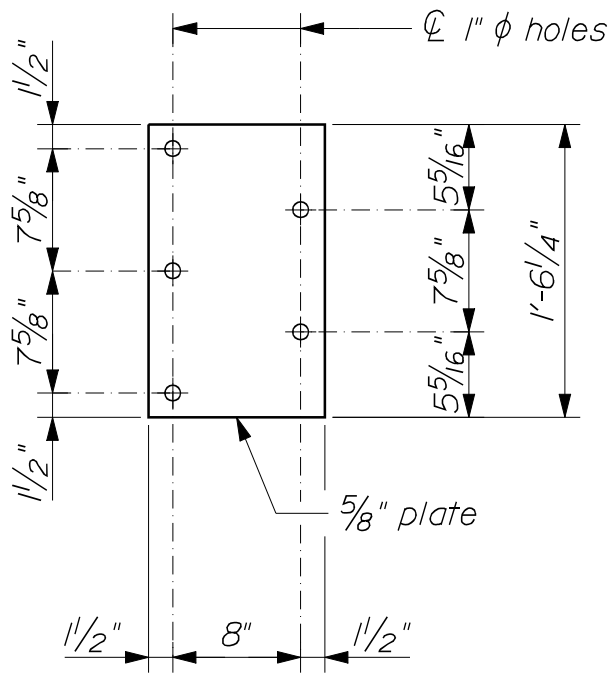

~ BEARING PLATE ~

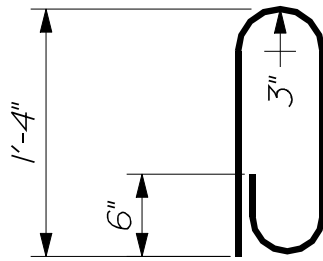

~ CR550 ~

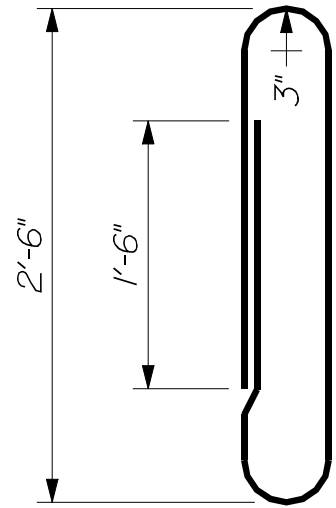

~ CR551 ~

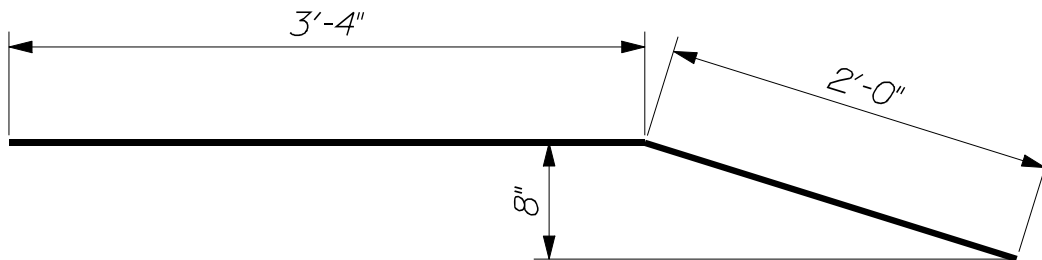

~ CR750 ~

TRAFFIC RAIL REINFORCING STEEL SCHEDULE					
Horizontal			Vertical		
Mark	Length	Location	Mark	Length	Location
CR500	30' max.	Rail Bot. & Curb	CR502	2'-2"	Nose
CR501	5'-3"	Nose/Post	CR503	2'-0"	Nose
			CR504	1'-10"	Nose
CR700	30' max.	Rail Top	CR505	1'-8"	Nose
CR750	5'-4"	Nose	CR506	1'-6"	Nose
			CR550	3'-9"	Rail & Post
			CR551	7'-1"	Rail & Post

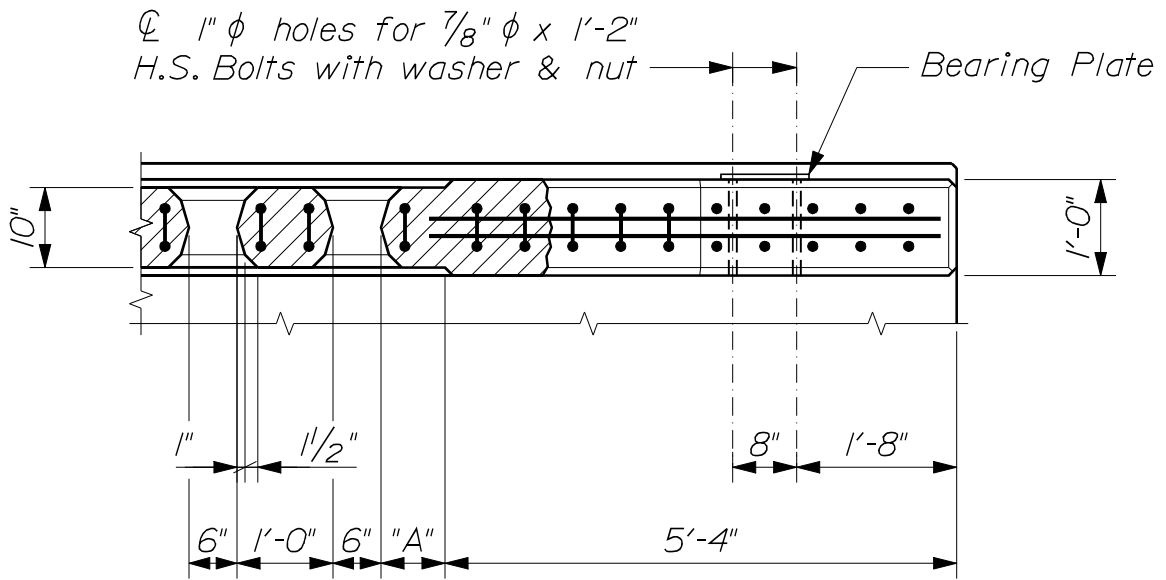

~ SIDEWALK RAIL PLAN ~

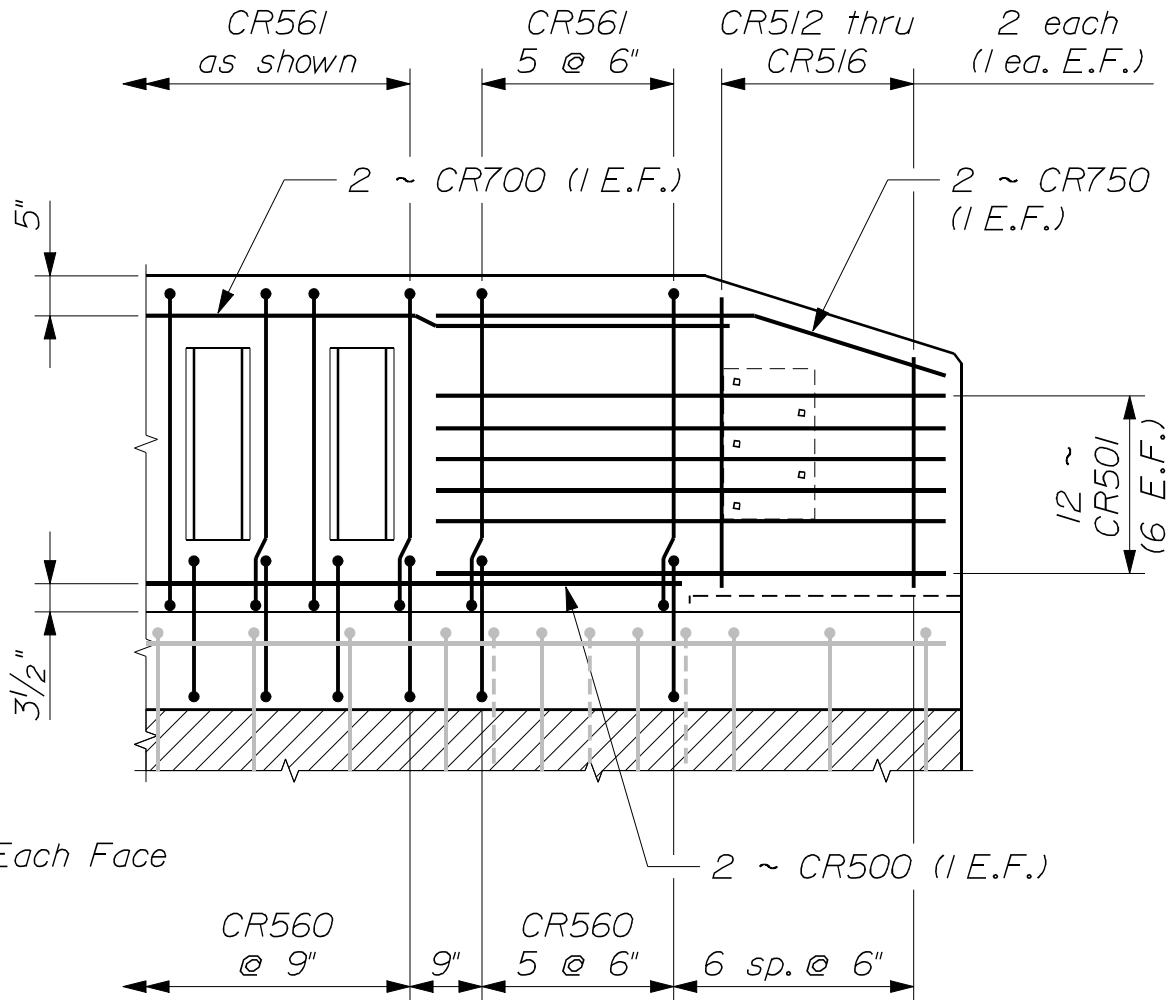

~ SIDEWALK RAIL ELEVATION ~

TEXAS CLASSIC RAIL  
 526(49)

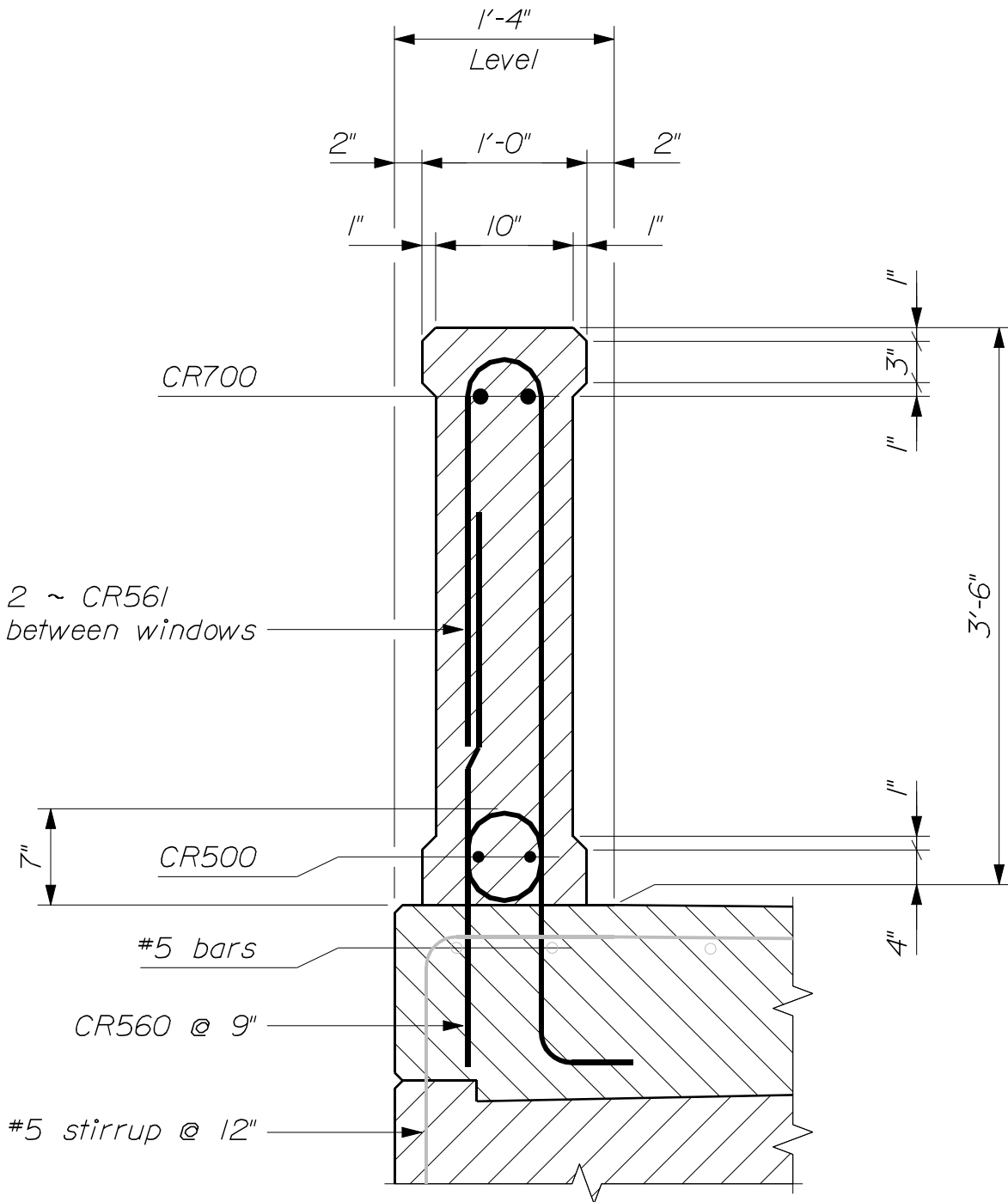

~ SECTION BETWEEN WINDOWS ~  
(Sidewalk Rail)

TEXAS CLASSIC RAIL  
526(50)

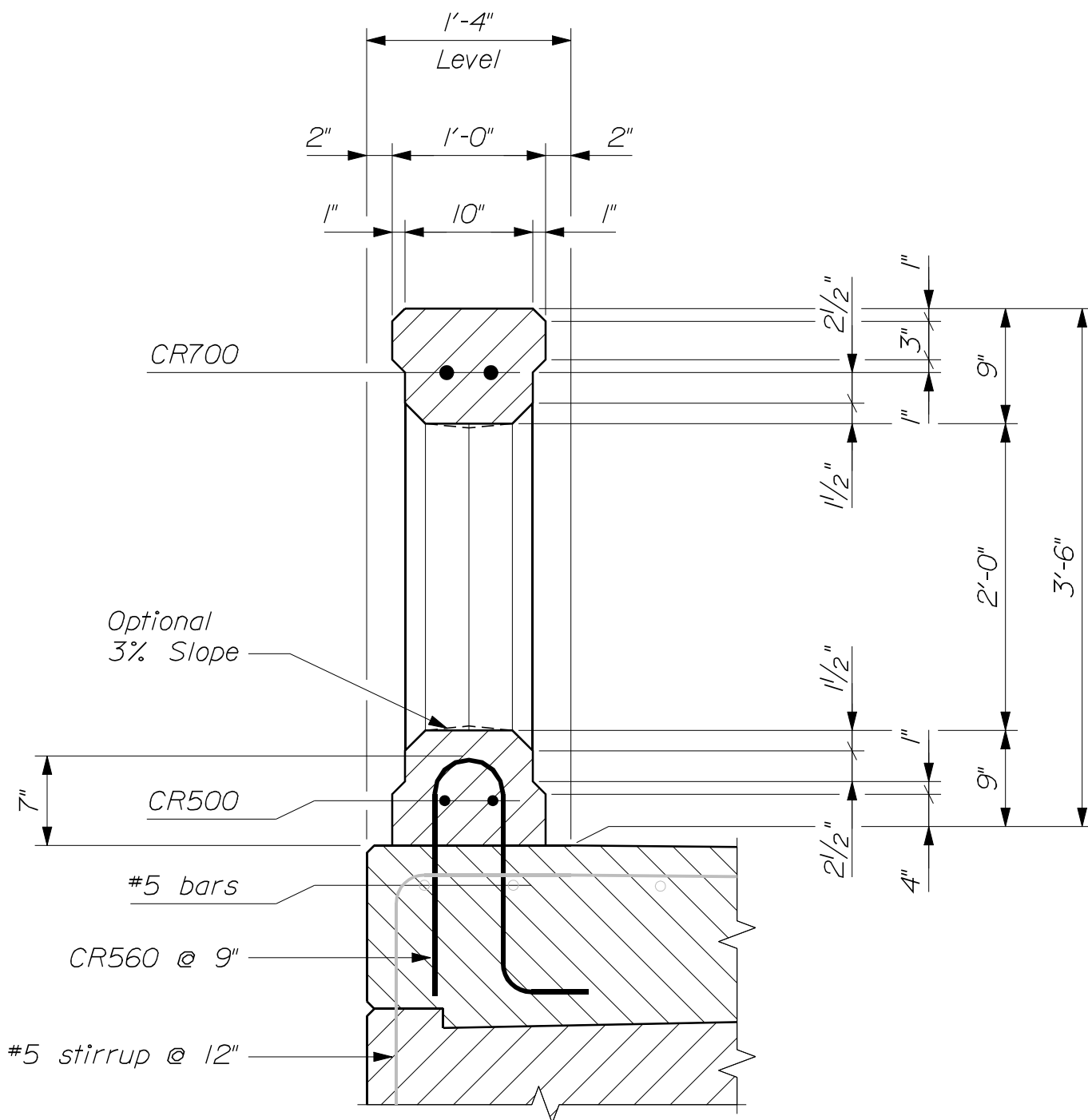

~ SECTION THROUGH WINDOW ~  
(Sidewalk Rail)

TEXAS CLASSIC RAIL  
526(51)

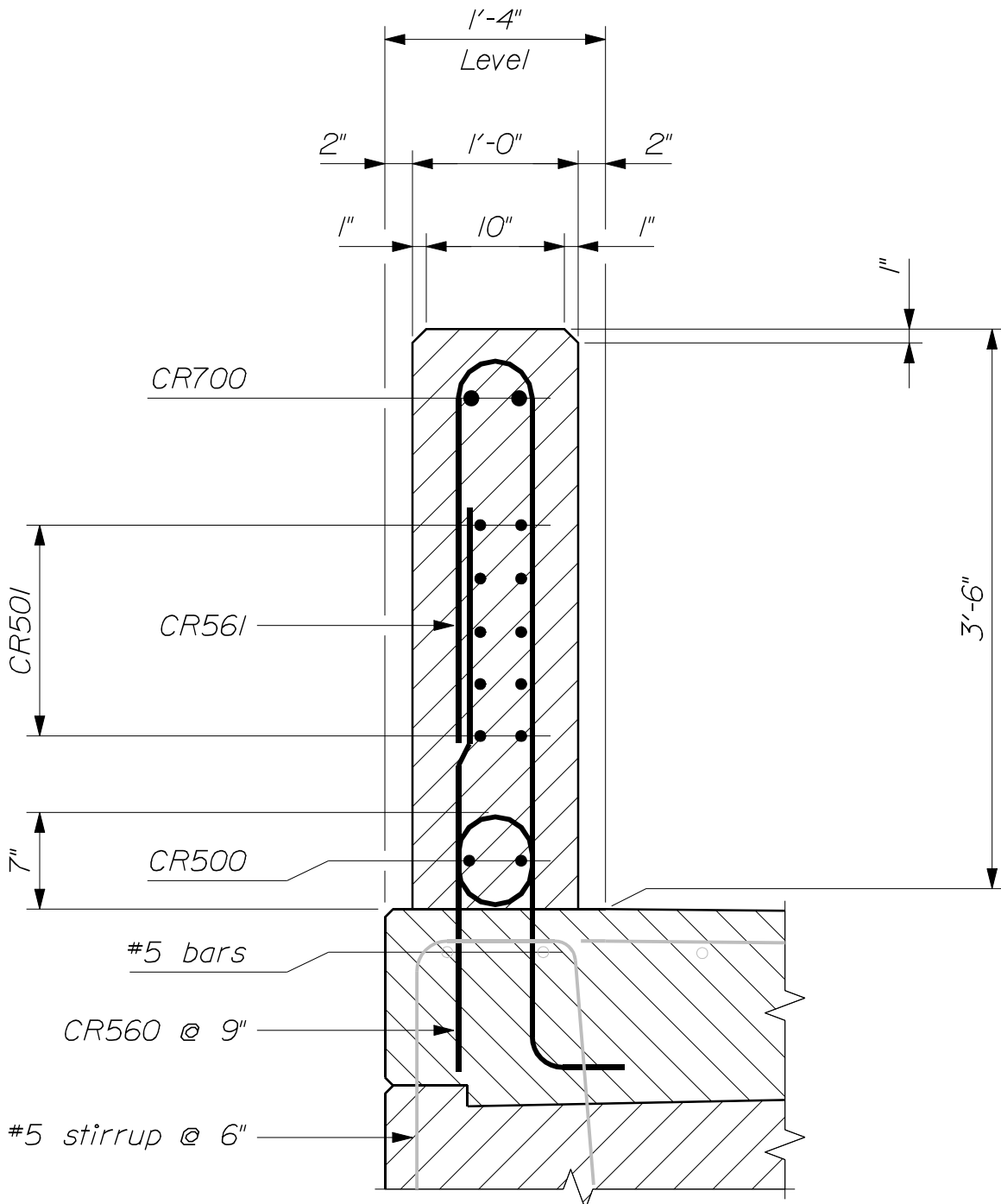

~ SECTION THROUGH POST ~  
(Sidewalk Rail)

TEXAS CLASSIC RAIL  
526(52)

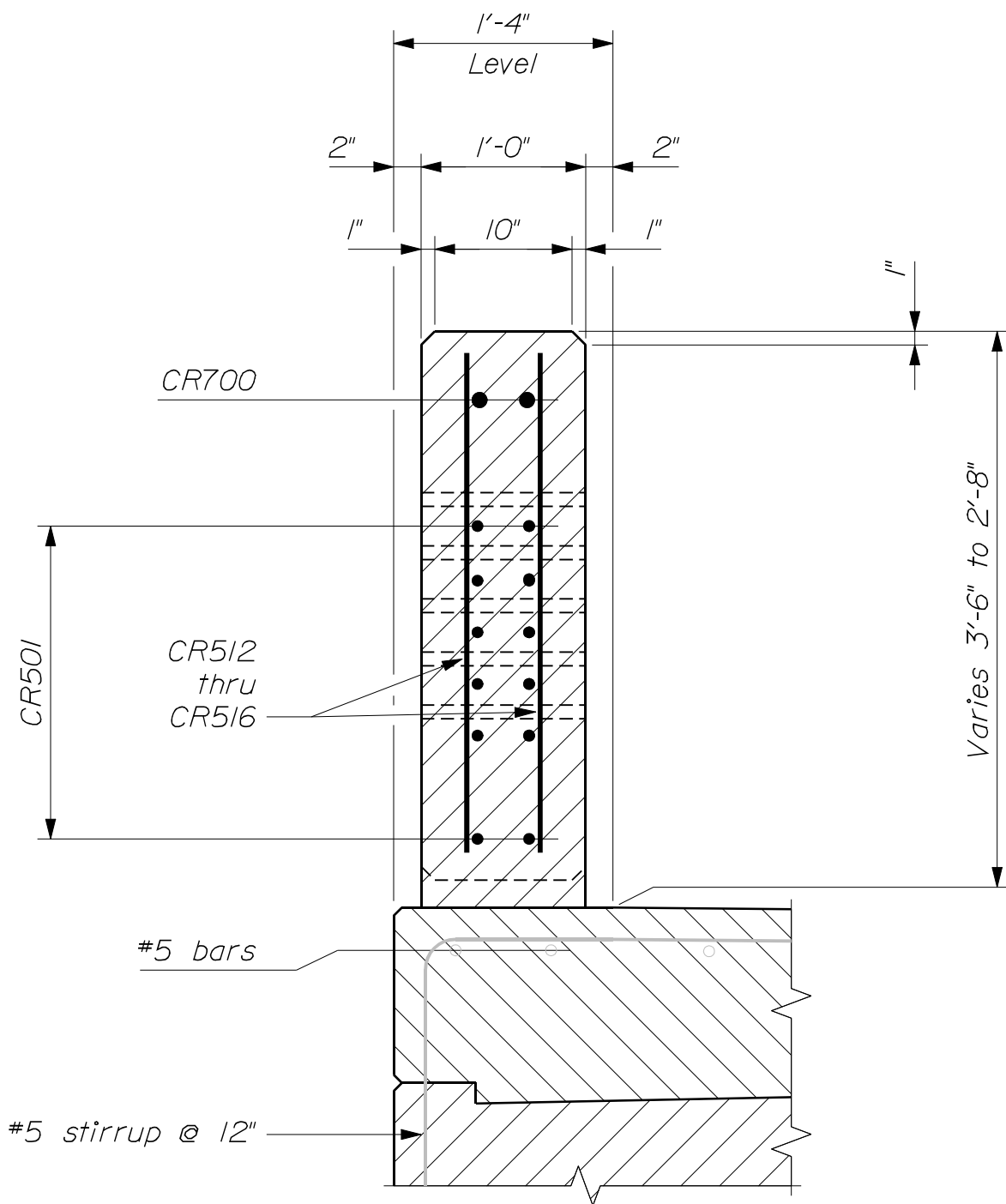

~ SECTION THROUGH NOSE ~  
(Sidewalk Rail)

TEXAS CLASSIC RAIL  
526(53)

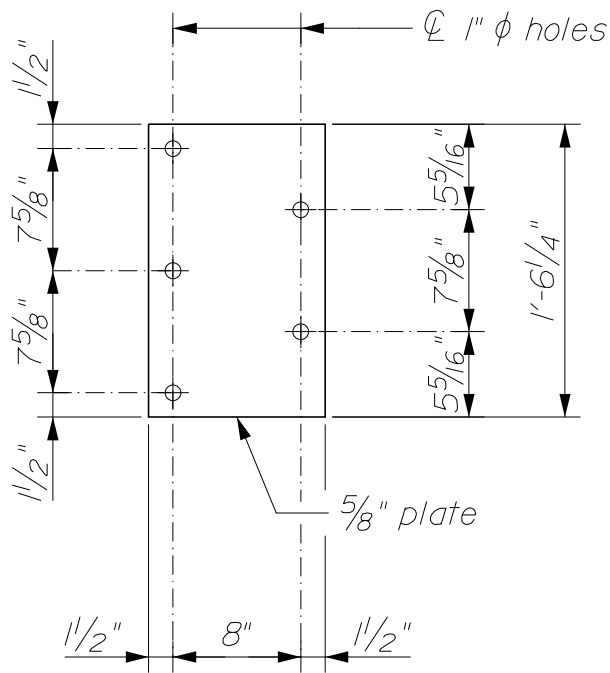

~ BEARING PLATE ~

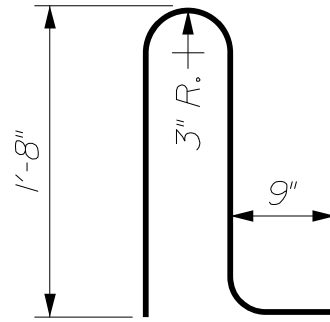

~ CR560 ~

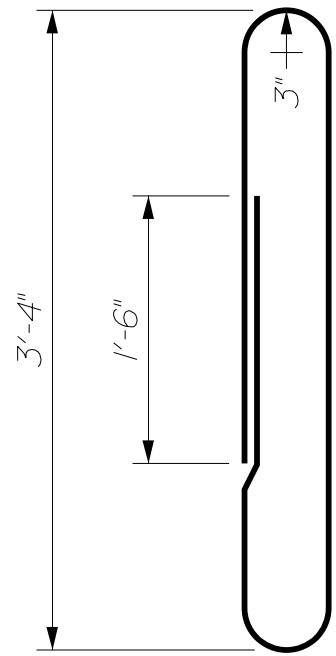

~ CR561 ~

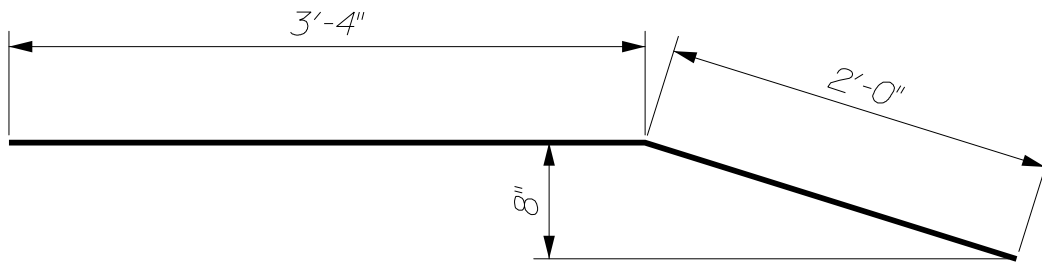

~ CR750 ~

SIDEWALK RAIL REINFORCING STEEL SCHEDULE					
Horizontal			Vertical		
Mark	Length	Location	Mark	Length	Location
CR500	30' max.	Rail Bot. & Curb	CR512	2'-11"	Nose
CR501	5'-3"	Nose/Post	CR513	2'-9"	Nose
			CR514	2'-7"	Nose
CR700	30' max.	Rail Top	CR515	2'-5"	Nose
CR750	5'-4"	Nose	CR516	2'-3"	Nose
			CR560	4'-0"	Rail & Post
			CR561	8'-9"	Rail & Post

NOTES:

1. All work and materials shall conform to the provisions of Standard Specifications Section 526 - Concrete Barrier.
2. Vertical surfaces and recesses shall be plumb. Tops and bottoms of window openings may be level or parallel to the grade of the rail.
3. Contraction joints shall be located over piers on continuous structures and at 30-ft ± intervals along the length of all bridges. Do not extend reinforcing steel through the contraction joints.
4. Reinforcing steel shall have a minimum concrete cover of 2 inches.
5. The first digit following the letters of the bar mark indicates the size of the reinforcing bar. (CR500 = #5 bar.) All dimensions are out - to - out of bar.
6. Minimum lap splice lengths for CR500 and CR700 shall be in accordance with Standard Specifications Subsection 503.07, Splicing.
7. When the end post is cantilevered over an expansion joint, provide a block - out as shown.
8. For details of curb / sidewalk expansion dams where necessary, refer to the Standard Detail for the appropriate Expansion Device.
9. Bolt holes in concrete shall be formed by a method approved by the Resident.
10. Payment for threaded rods, nuts, washers and bearing plates will be considered incidental to the Texas Classic Rail pay item.
11. For details of the Concrete Transition Curb, refer to Standard Details Section 609, Precast Concrete Transition Curb. Payment for the transition curb will be considered incidental to the Texas Classic Rail pay item.

MATERIALS:

Concrete ..... Class "LP"  
Reinforcing Steel ..... AASHTO M 31M/M 31, Grade 60  
Bearing Plate ..... AASHTO M 270M/M 270, Grade 36 (Galvanized)  
Threaded rods ..... AASHTO M 314, Grade 105 (Galvanized)

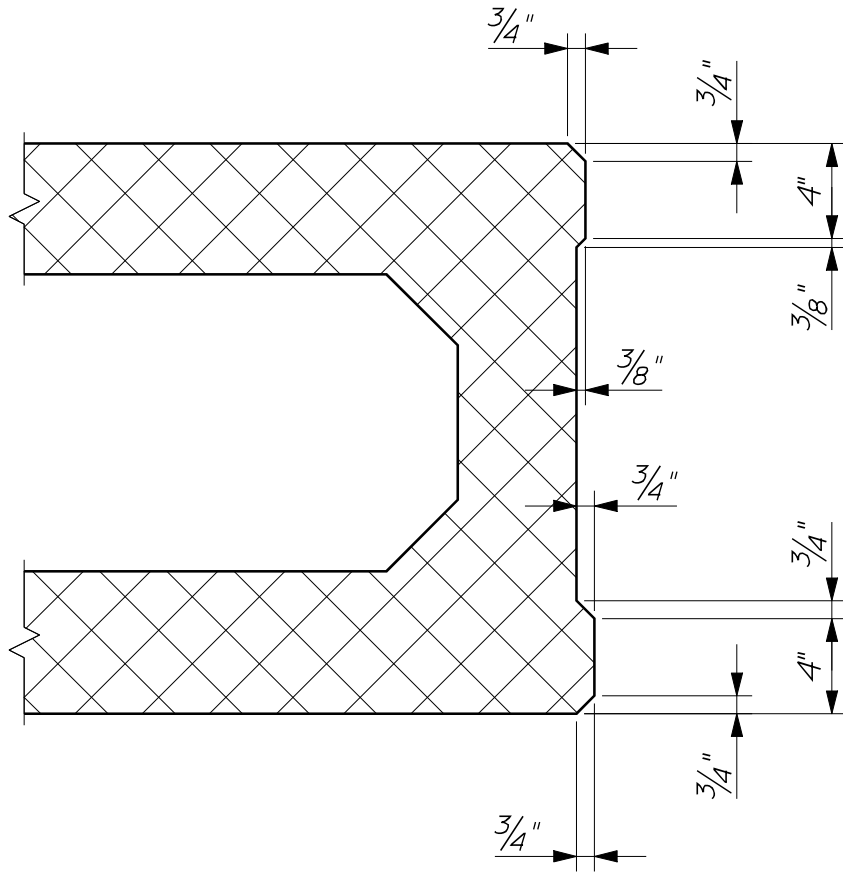

~ SHEAR KEY DIMENSIONS ~  
 (Typical for all precast slabs and box beams)

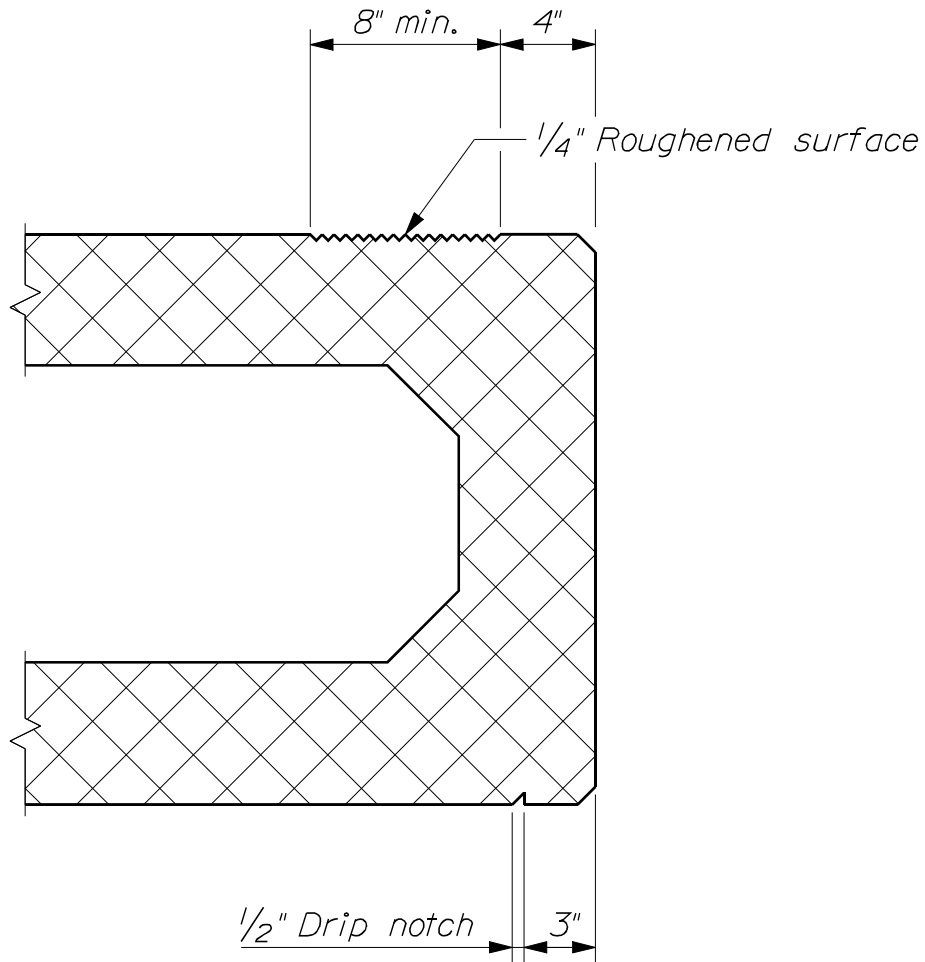

~ FASCIA DETAILS ~  
 (Exterior units only)  
 (Entire top surface is roughened with reinforced C.I.P. slab)

PRECAST SUPERSTRUCTURE  
 535(02)

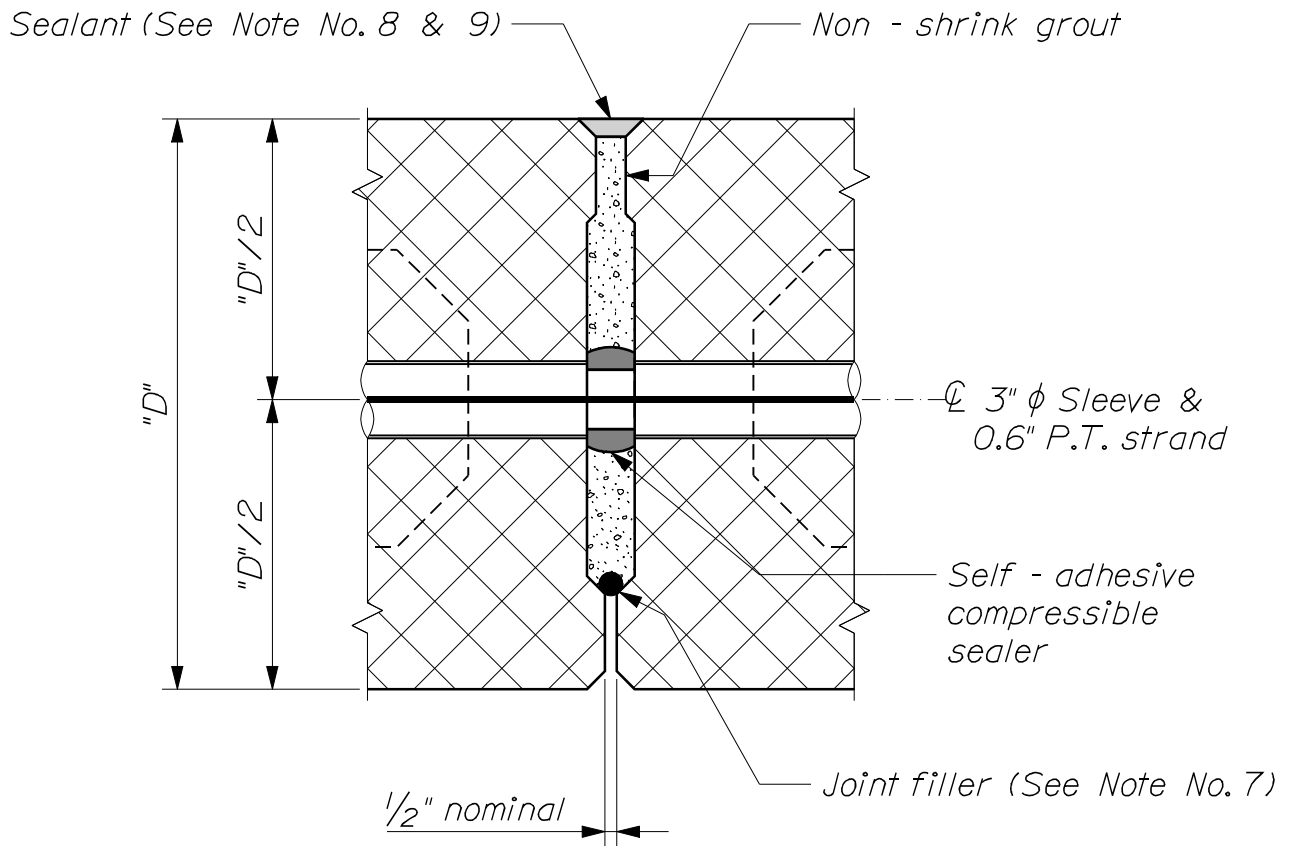

~ SHEAR KEY DETAIL ~  
 (For precast slabs and box beams where "D"  $\leq$  24")

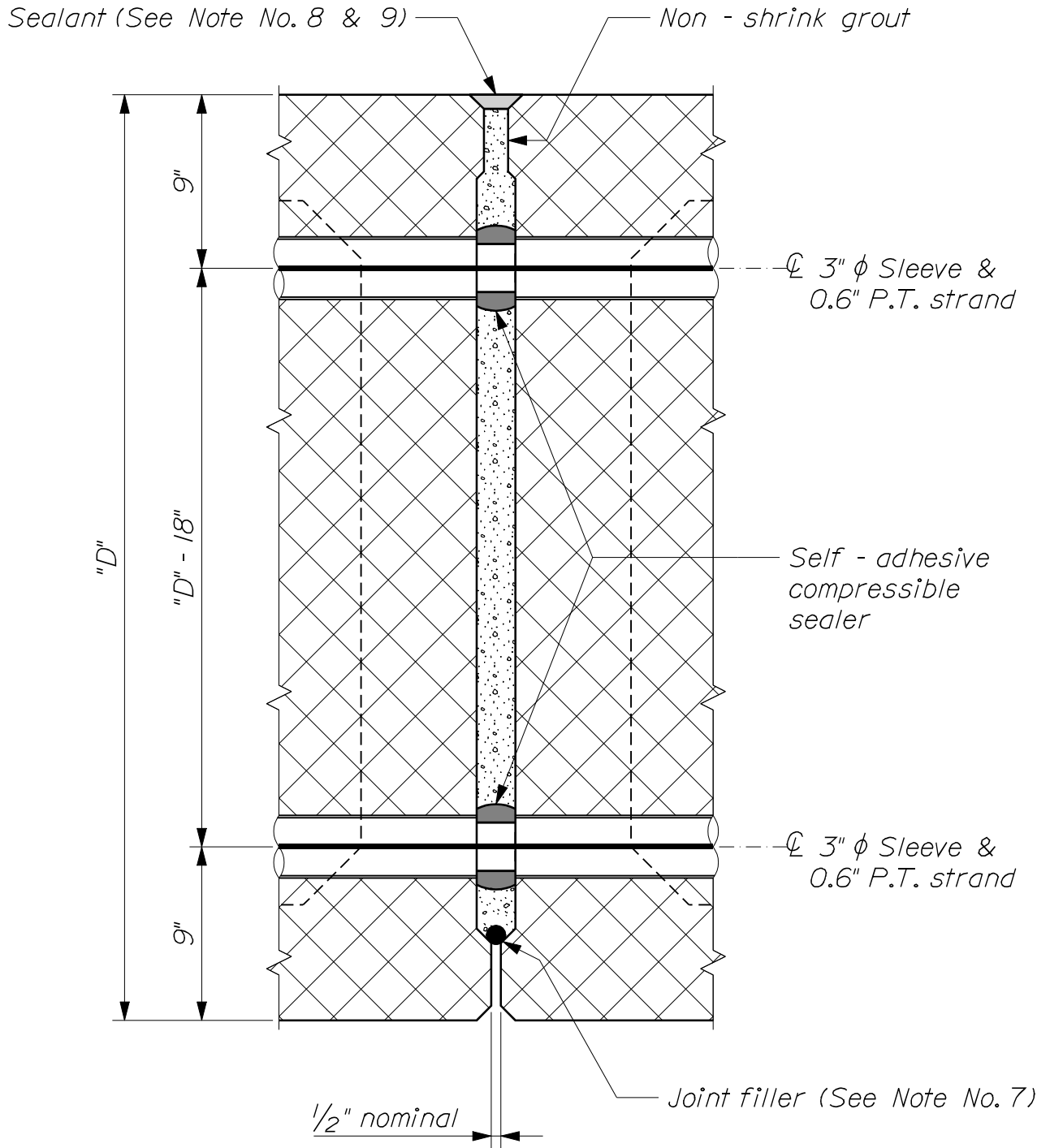

~ SHEAR KEY DETAIL ~  
 (For precast box beams where "D"  $\geq$  27")

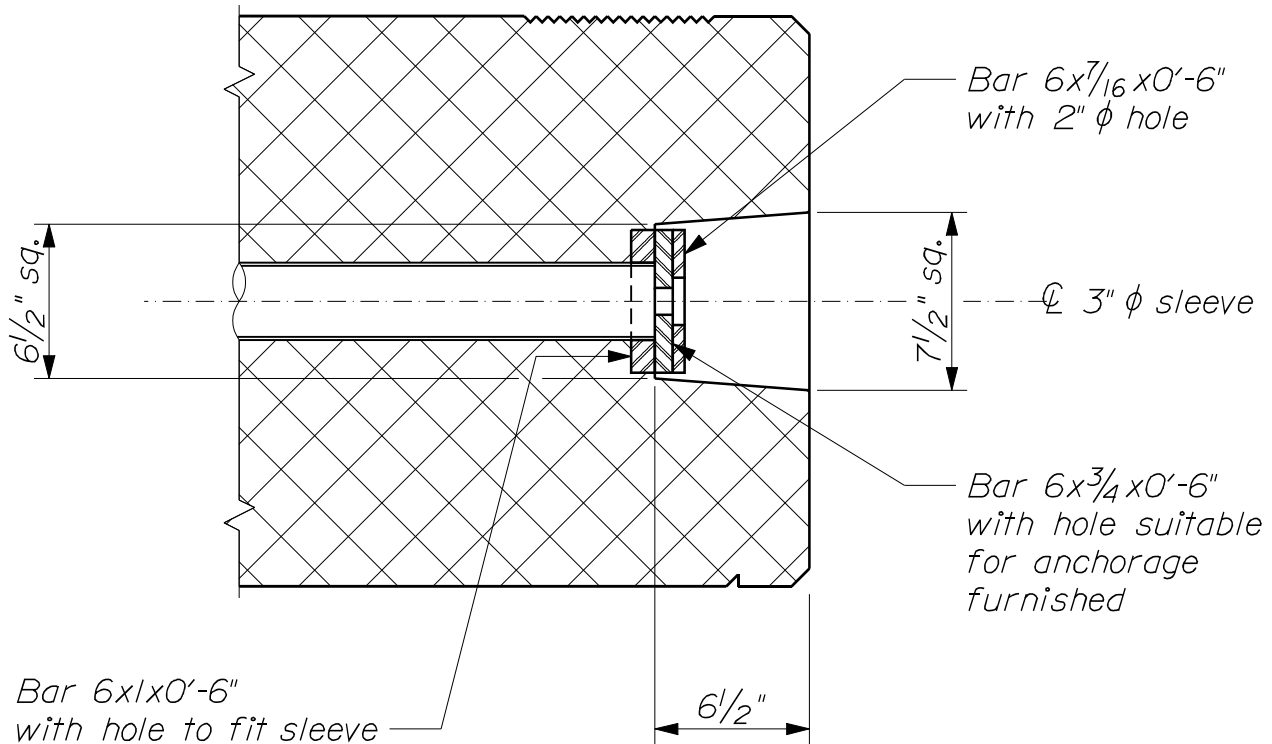

-- POST - TENSIONING BLOCK - OUT DETAIL --

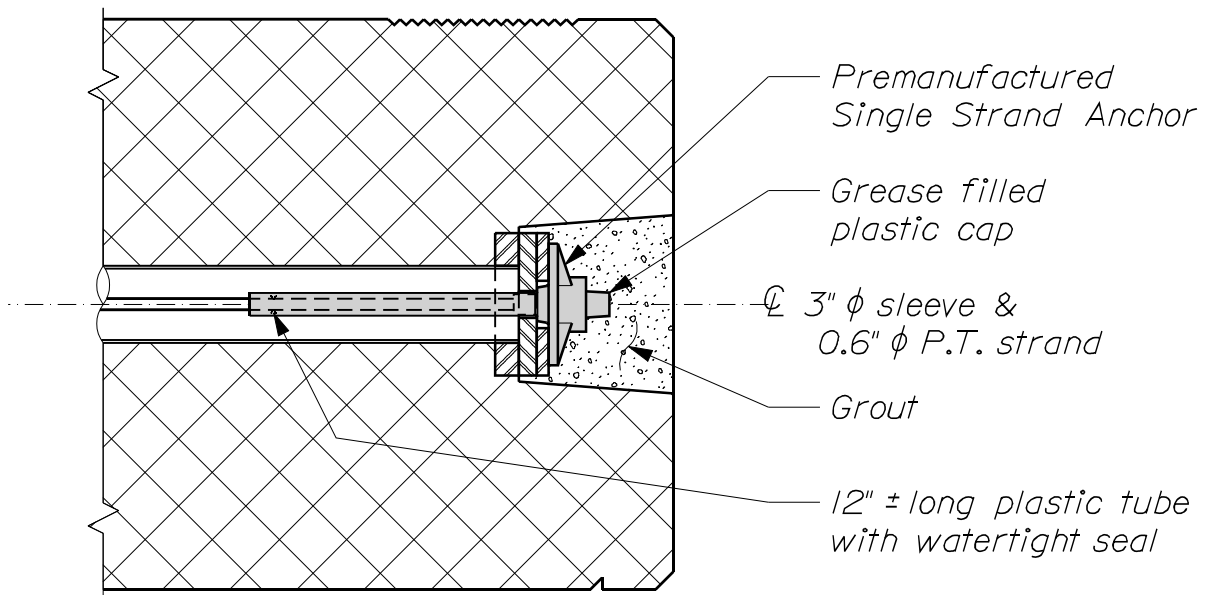

-- POST - TENSIONING ANCHORAGE DETAIL --

\* Anchoring Material = Fixed  
Sealant = Expansion

℄ Bearing, Abutment

Membrane  
Waterproofing

Leveling Slab

Anchoring  
Material  
or Sealant \*

1'-0"

1'-0"

6"

Neoprene pad

#8 rebar  
(Drill & anchor)

~ LONGITUDINAL SECTION ~

1/2" Pad (Slabs)  
1" Pad (Box Beams)

2" φ PVC sleeve

3" max.

~ TRANSVERSE SECTION ~

# PRECAST SUPERSTRUCTURE

535(06)

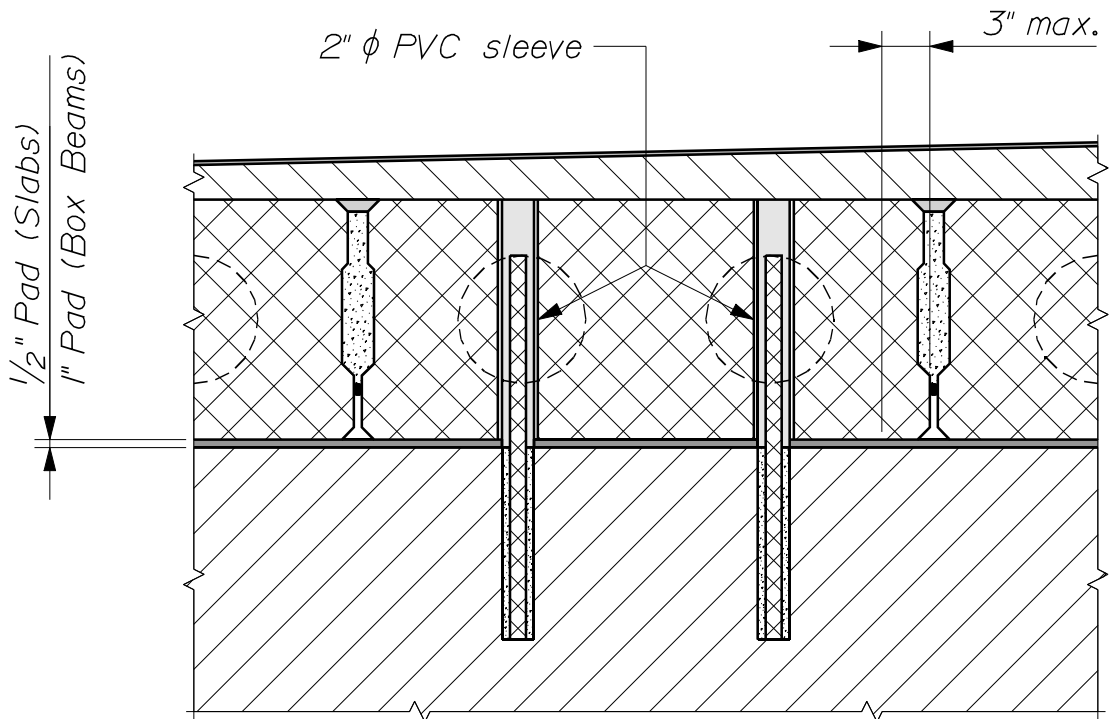
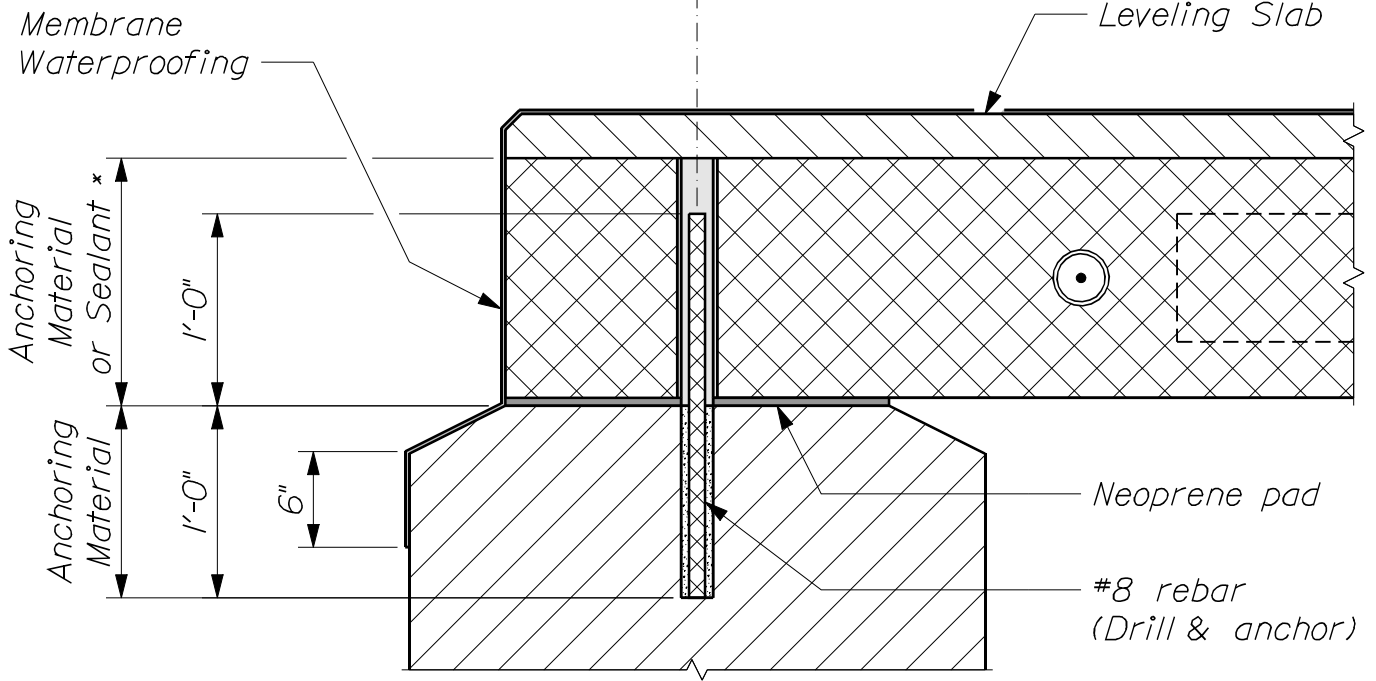

<i>PRECAST SLABS</i>						
<i>Slab Type</i>	<i>Nom. Width</i>	<i>Depth "D"</i>	<i>Void "φ<sub>1</sub>"</i>	<i>Void "φ<sub>2</sub>"</i>	<i>Spacing "X<sub>1</sub>"</i>	<i>Spacing "X<sub>2</sub>"</i>
<i>S36-12</i>	<i>36"</i>	<i>12"</i>	<i>--</i>	<i>--</i>	<i>--</i>	<i>--</i>
<i>S36-15</i>	<i>36"</i>	<i>15"</i>	<i>8"</i>	<i>--</i>	<i>10"</i>	<i>15½"</i>
<i>S36-18</i>	<i>36"</i>	<i>18"</i>	<i>10"</i>	<i>--</i>	<i>10"</i>	<i>15½"</i>
<i>S36-21</i>	<i>36"</i>	<i>21"</i>	<i>12"</i>	<i>--</i>	<i>10"</i>	<i>15½"</i>
<i>S48-12</i>	<i>48"</i>	<i>12"</i>	<i>--</i>	<i>--</i>	<i>--</i>	<i>--</i>
<i>S48-15</i>	<i>48"</i>	<i>15"</i>	<i>8"</i>	<i>8"</i>	<i>10"</i>	<i>13¾"</i>
<i>S48-18</i>	<i>48"</i>	<i>18"</i>	<i>10"</i>	<i>10"</i>	<i>9½"</i>	<i>14¼"</i>
<i>S48-21</i>	<i>48"</i>	<i>21"</i>	<i>12"</i>	<i>10"</i>	<i>9½"</i>	<i>14¼"</i>

<i>PRECAST BOX BEAMS</i>					
<i>Box Type</i>	<i>Nom. Width</i>	<i>Depth "D"</i>	<i>Box Type</i>	<i>Nom. Width</i>	<i>Depth "D"</i>
<i>B36-24</i>	<i>36"</i>	<i>24"</i>	<i>B48-24</i>	<i>48"</i>	<i>24"</i>
<i>B36-27</i>	<i>36"</i>	<i>27"</i>	<i>B48-27</i>	<i>48"</i>	<i>27"</i>
<i>B36-30</i>	<i>36"</i>	<i>30"</i>	<i>B48-30</i>	<i>48"</i>	<i>30"</i>
<i>B36-33</i>	<i>36"</i>	<i>33"</i>	<i>B48-33</i>	<i>48"</i>	<i>33"</i>
<i>B36-36</i>	<i>36"</i>	<i>36"</i>	<i>B48-36</i>	<i>48"</i>	<i>36"</i>
<i>B36-39</i>	<i>36"</i>	<i>39"</i>	<i>B48-39</i>	<i>48"</i>	<i>39"</i>
<i>B36-42</i>	<i>36"</i>	<i>42"</i>	<i>B48-42</i>	<i>48"</i>	<i>42"</i>
<i>B36-45</i>	<i>36"</i>	<i>45"</i>	<i>B48-45</i>	<i>48"</i>	<i>45"</i>
<i>B36-48</i>	<i>36"</i>	<i>48"</i>	<i>B48-48</i>	<i>48"</i>	<i>48"</i>

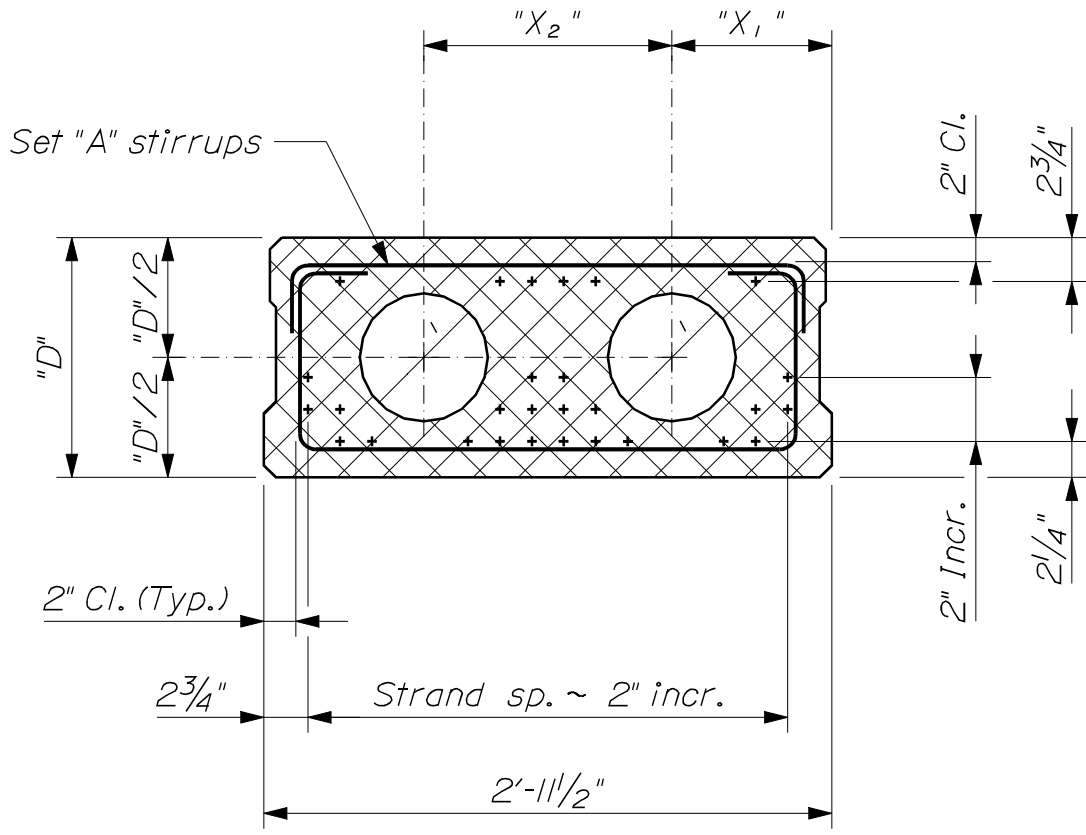

~ TYPICAL SECTION ~  
(36" Wide Precast Slab)

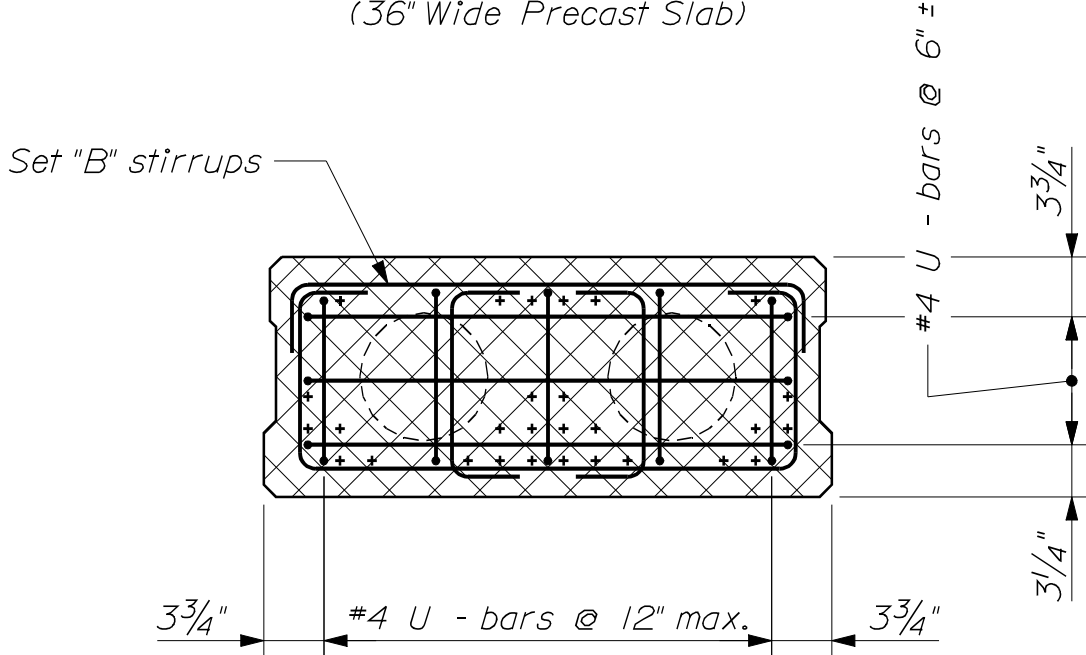

~ END BLOCK SECTION ~  
(36" Wide Precast Slab)

PRECAST SUPERSTRUCTURE  
535(08)

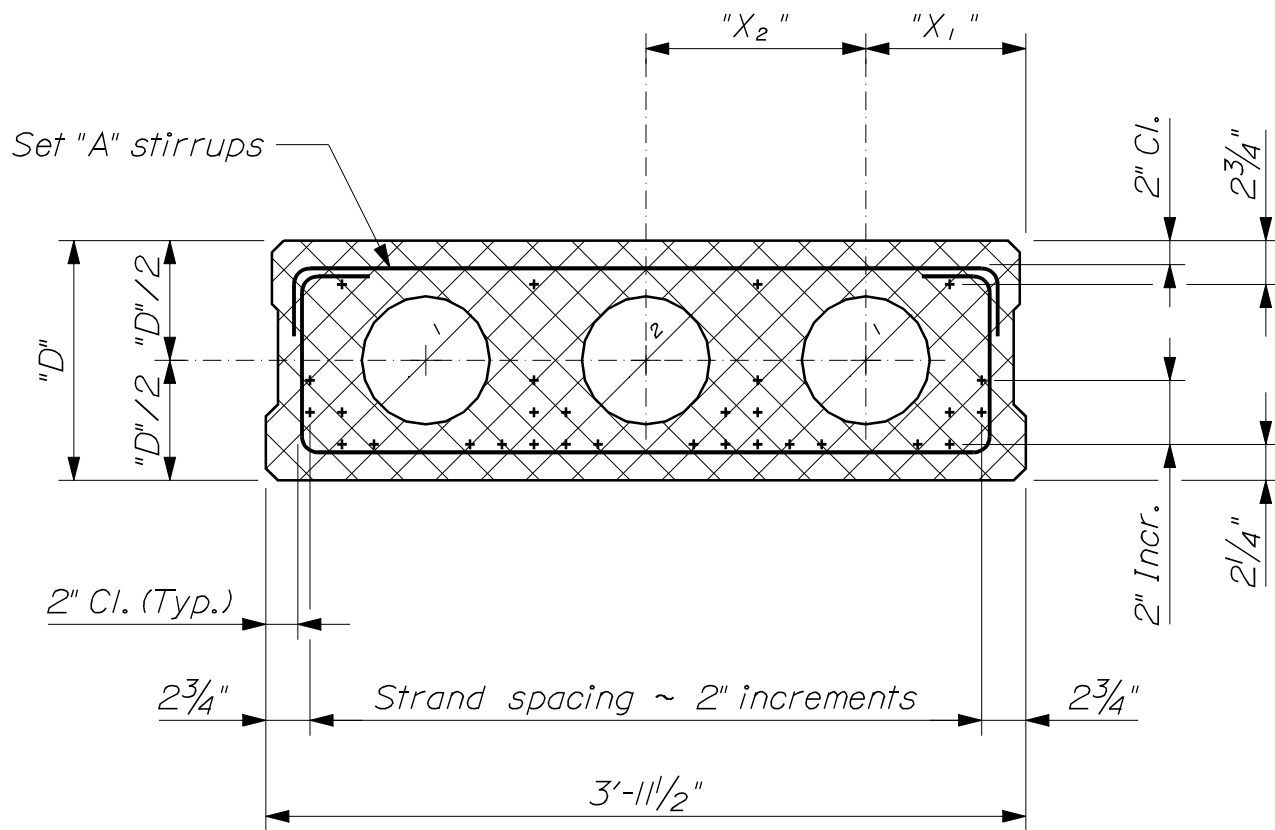

~ TYPICAL SECTION ~  
(48" Wide Precast Slab)

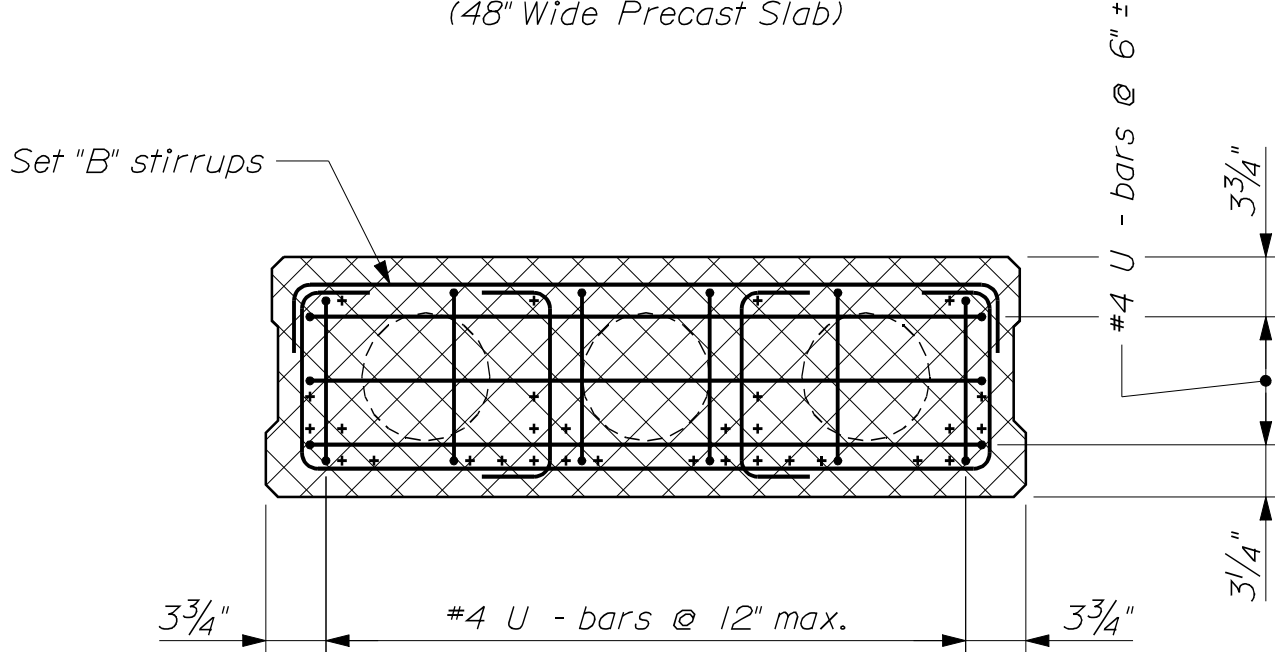

~ END BLOCK SECTION ~  
(48" Wide Precast Slab)

PRECAST SUPERSTRUCTURE  
535(09)

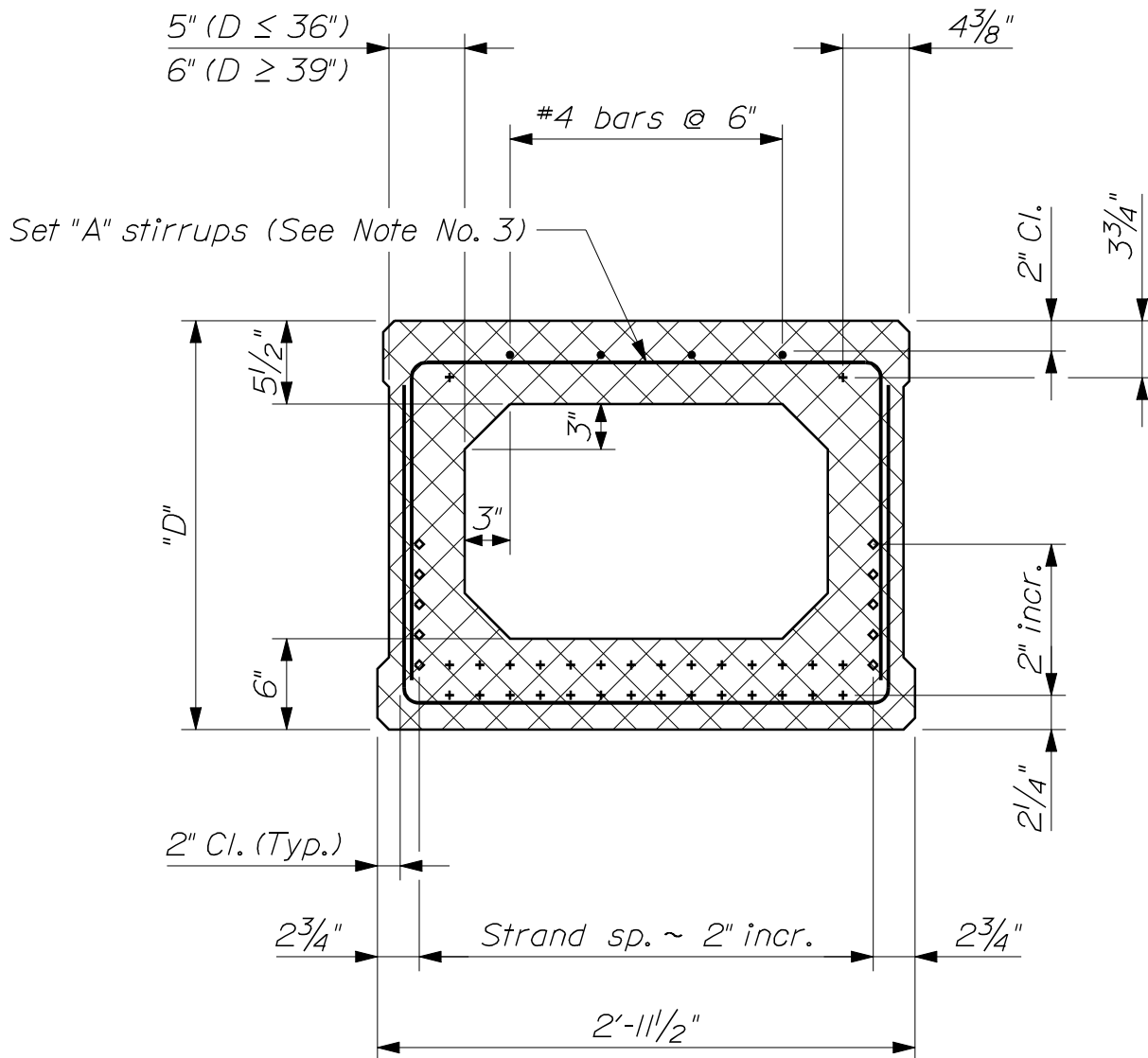

~ TYPICAL SECTION ~  
 (36" Wide Precast Box Beam)

- + Straight Strands
- ◊ Draped Strands

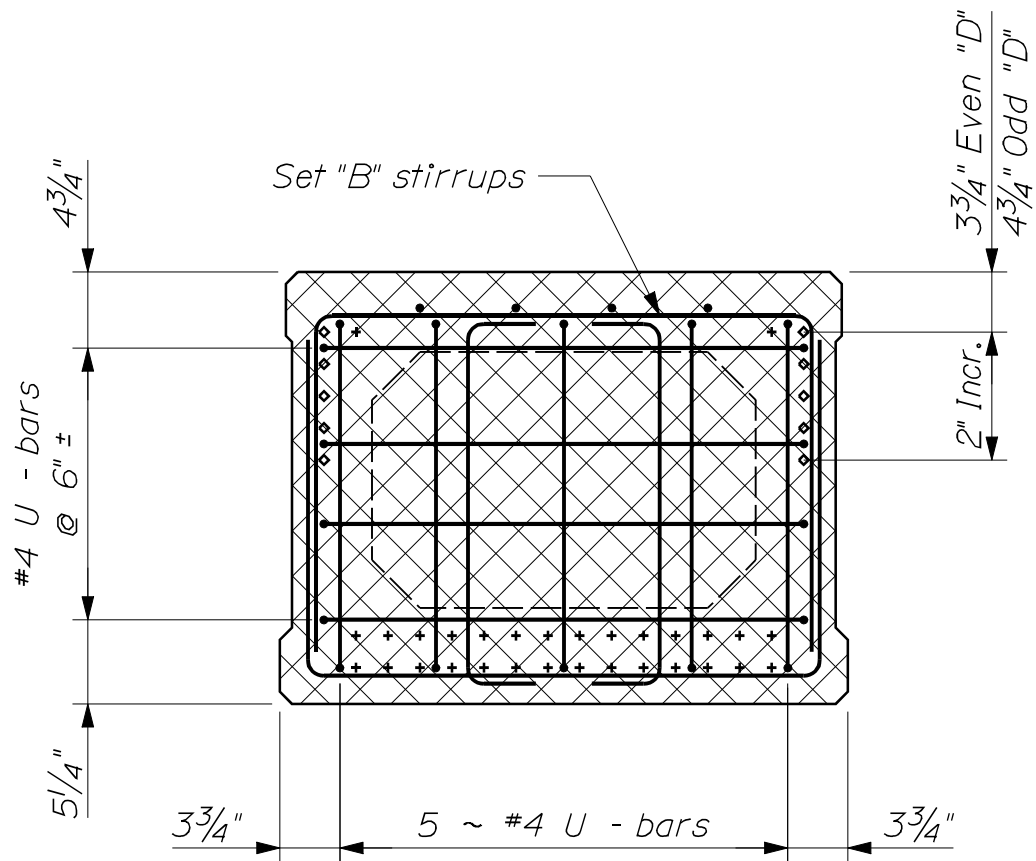

~ END BLOCK SECTION ~  
 (36" Wide Precast Box Beam)

- + Straight Strands
- ◇ Draped Strands

**PRECAST SUPERSTRUCTURE**  
 535(II)

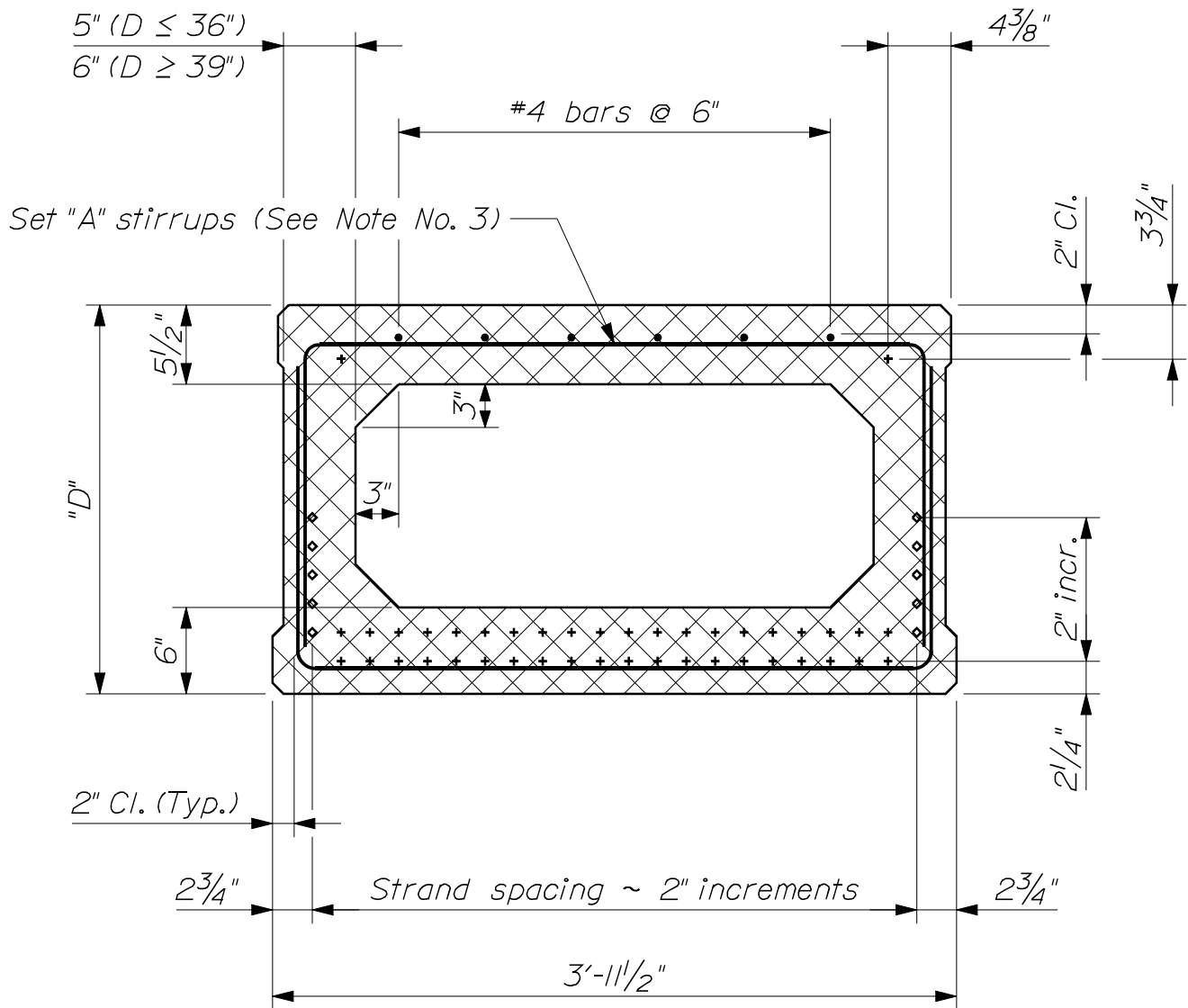

~ TYPICAL SECTION ~  
 (48" Wide Precast Box Beam)

- + Straight Strands
- ◊ Draped Strands

PRECAST SUPERSTRUCTURE  
 535(12)

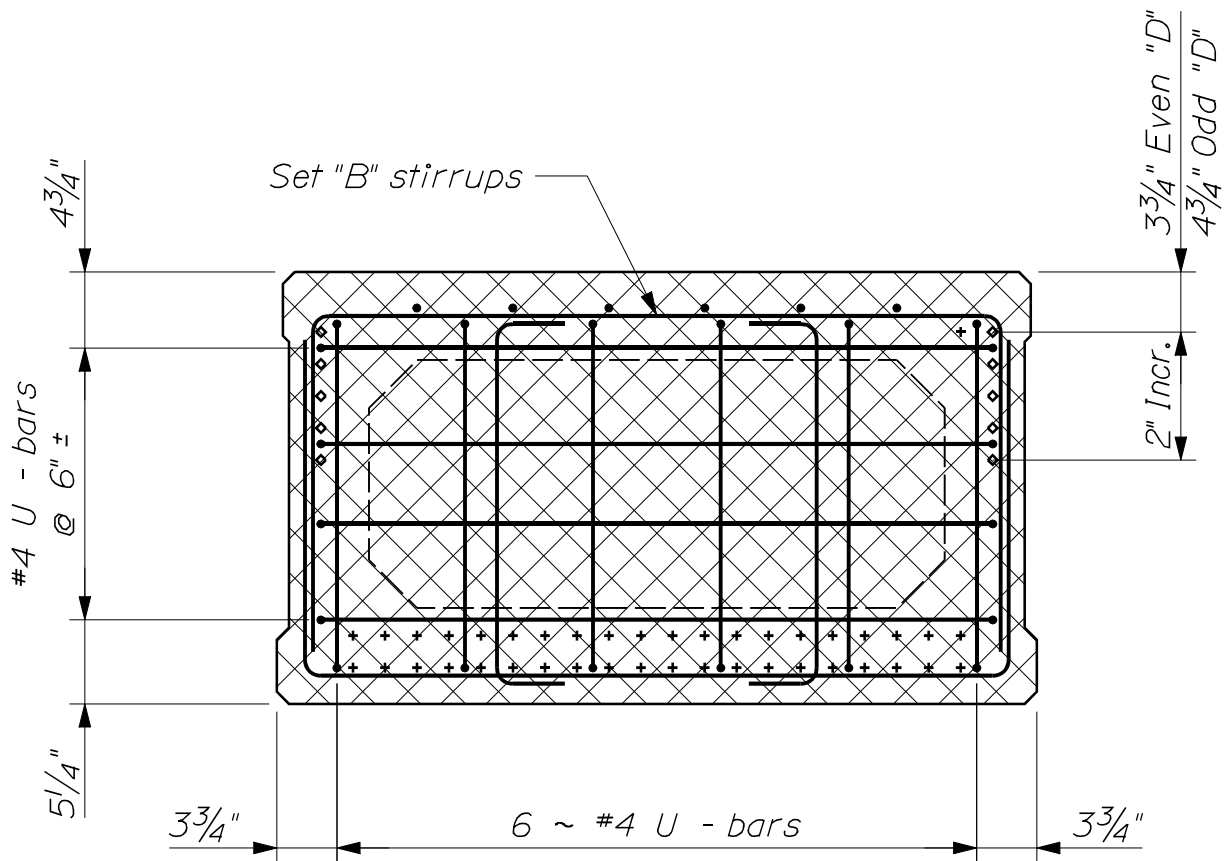

~ END BLOCK SECTION ~  
(48" Wide Precast Box Beam)

- + Straight Strands
- ◇ Draped Strands

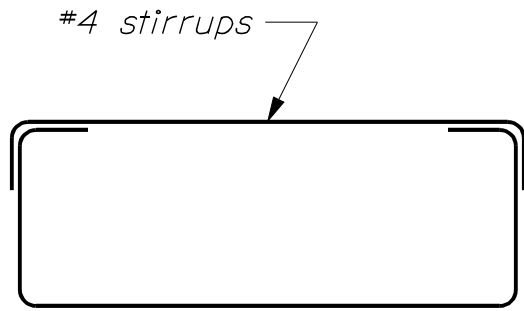

~ SET "A" STIRRUPS ~  
(Precast Slab)

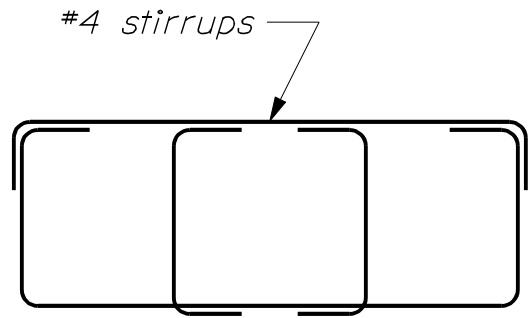

~ SET "B" STIRRUPS ~  
(Precast Slab)

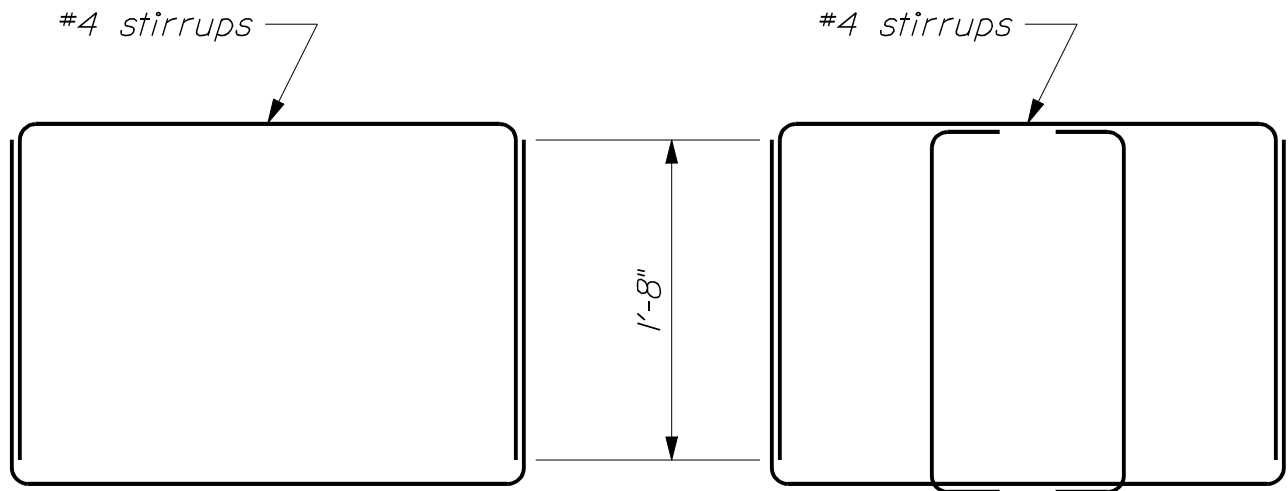

~ SET "A" STIRRUPS ~  
(Precast Box Beam)

~ SET "B" STIRRUPS ~  
(Precast Box Beam)

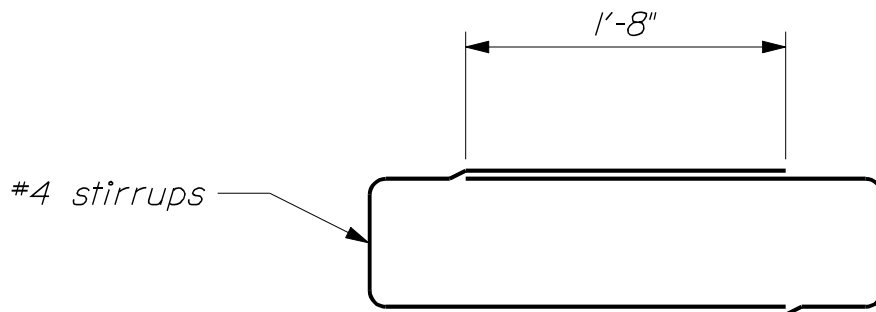

~ ALTERNATE STIRRUP CONFIGURATION ~  
(Always use for S36-12 and S48-12 slabs)

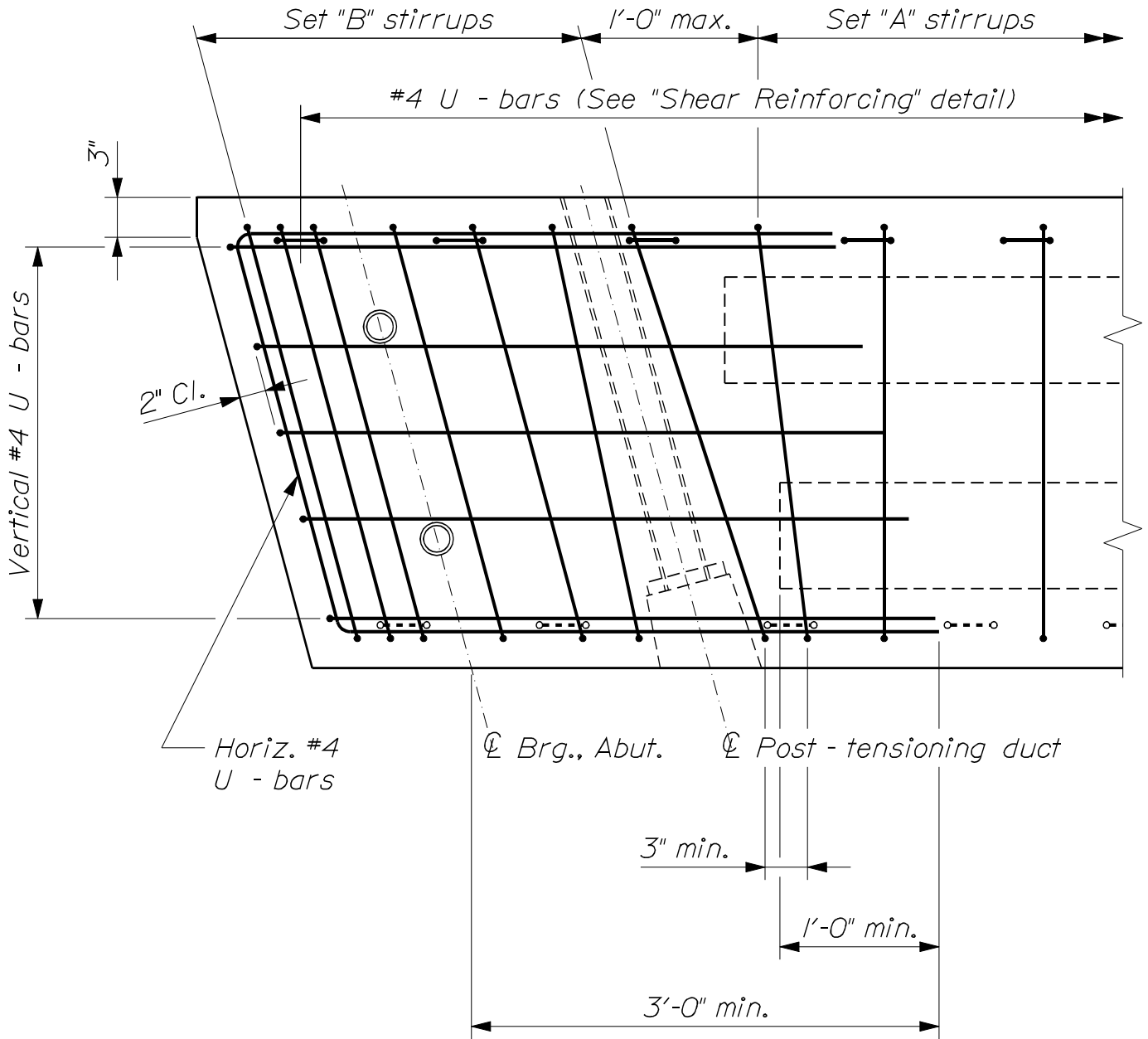

~ TYPICAL PRECAST UNIT PLAN ~  
 (Voided Slab shown; Box Beam similar)

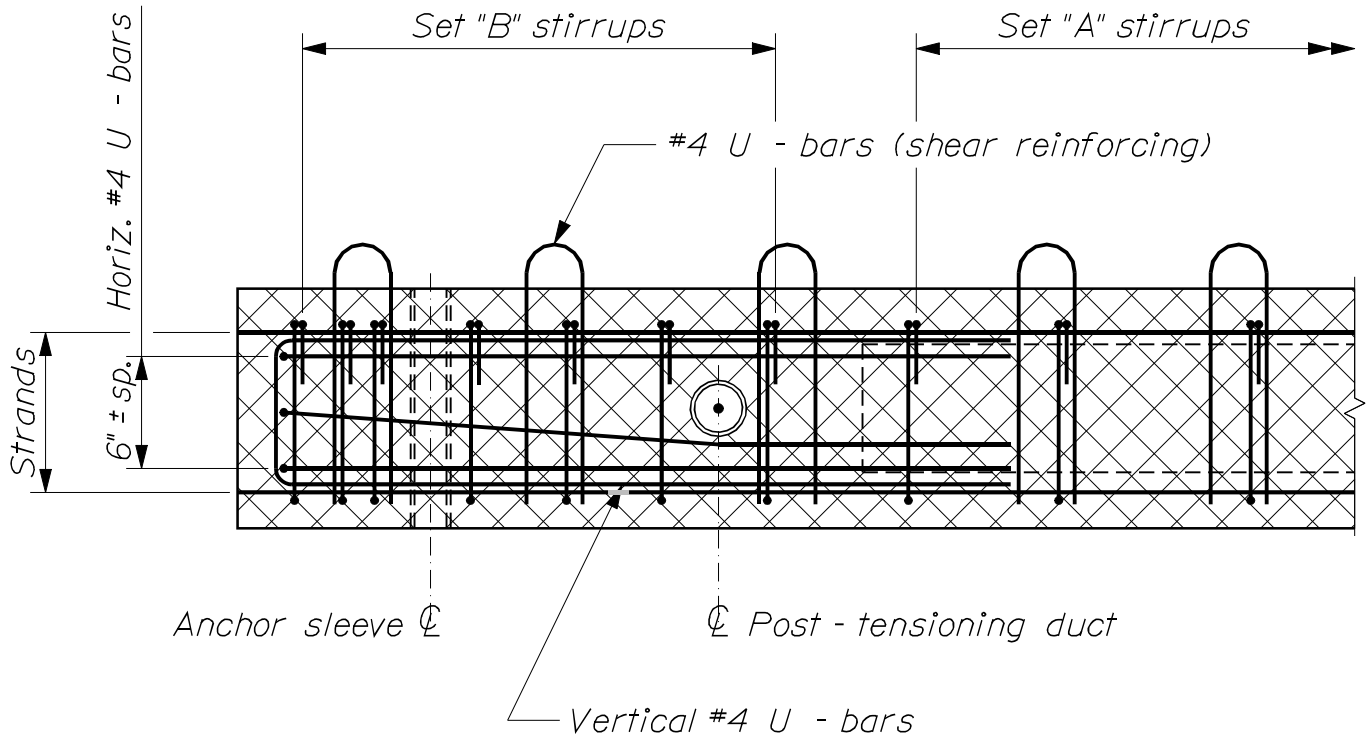

~ TYPICAL LONGITUDINAL SECTION ~

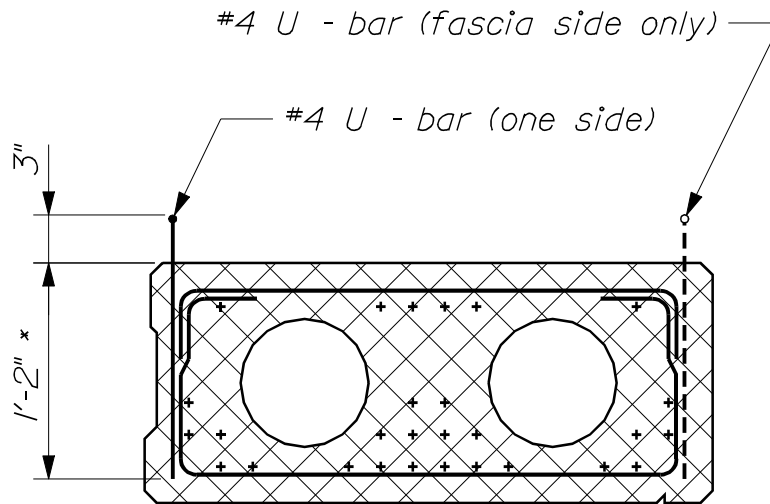

~ SHEAR REINFORCING ~  
(For use with reinforced C.I.P. slab)

\* 10" for S12 slabs  
12" for S15 slabs

## NOTES:

1. *Prestressing strands shown in the various details are schematic in nature and do not represent any specific design requirements.*
2. *Reinforcing steel shown is the required minimum. Individual designs may vary. Bending details and hooks shall conform to the recommendations of the current revision of ACI Standards 315 and 318.*
3. *For box beams, unless the design drawings specify a separate reinforced concrete slab to be constructed over the box beams, additional upper #4 stirrups shall be provided such that the maximum spacing of the upper stirrups over the voided areas is 12 inches.*
4. *All plates in the post - tensioning block - out detail shall be galvanized in accordance with ASTM A 123.*
5. *Concrete around lifting devices shall be recessed a minimum of one inch below the surface. The recess shall be patched with an approved grout after removal of the lifting device.*
6. *For bridge skew angles up to 15°, the neoprene pad at the bearing area shall cover the entire bridge seat. Seams perpendicular to the centerline of bearing will be allowed provided that the seam occurs near the center of a precast unit with the unit bearing approximately equally on both pad pieces. For bridge skew angles greater than 15°, other bearing area treatment may be shown on the design drawings.*
7. *The Contractor will be responsible for providing a joint filler system adequate to contain the keyway grout during placement. No extra payment will be made for such system or for necessary repairs or other extra work if the joint filler system fails.*
8. *The shear key sealant shall be one of the polyurethane - based products listed on the MaineDOT Qualified Products List of Pour - In - Place Joint Sealant.*
9. *When a high - performance waterproofing membrane is to be applied directly to the top of the precast units, eliminate the shear key sealant and fill the shear key to the top of the unit with non - shrink grout.*
10. *If there is a conflict between these Standard Details and the Design Drawings, the requirements of the Design Drawings shall be followed.*